

Microwave Journal

COVER FEATURE
INVITED PAPER

Editor's Note: At the end of December, the 3GPP approved the 5G non-standalone new radio (NSA NR) specification, which defines how enhanced broadband services can be deployed using a 5G NR leveraging the existing LTE network. This NSA architecture will first be fielded—later this year—for fixed wireless access (FWA) services using mmWave spectrum, i.e., 28 and 39 GHz.

Qorvo and Anokiwave are two companies leading the development of the mmWave front-end technology for the active phased arrays that will power these FWA services. Each company has analyzed the system requirements and defined a unique approach to meeting them. Qorvo has chosen GaN, Anokiwave silicon. We are fortunate that this issue of *Microwave Journal* features articles from both, each stating the case for its technology choice. Regardless of which argument you favor, no doubt you will agree that both companies are doing excellent technology and product development, a key step to making 5G viable.

5G Fixed Wireless Access Array and RF Front-End Trade-Offs

Bror Peterson and David Schnauffer
Qorvo, Greensboro, N.C.

The vision of next-generation 5G networks is to deliver an order-of-magnitude improvement in capacity, coverage and connectivity compared to existing 4G networks, all at substantially lower cost per bit to carriers and consumers. The many use cases and services enabled by 5G technology and networks are shown in **Figure 1**. In this first phase of 5G new radio (NR) standardization, the primary focus has been on defining a radio access technology (RAT) that takes advantage of new wideband frequency allocations, both sub-6 GHz and above 24 GHz, to achieve the huge peak throughputs and low latencies proposed by the International Mobile Telecommunications vision for 2020 and beyond.¹

Mobile network operators are capitalizing on the improvements introduced by NR RAT, particularly in the mmWave bands, to deliver

gigabit fixed wireless access (FWA) services to houses, apartments and businesses, in a fraction of the time and cost of traditional cable and fiber to the home installations. Carriers are also using FWA as the

testbed toward a truly mobile broadband experience. Not surprisingly, Verizon, AT&T and other carriers are aggressively trialing FWA, with the goal of full commercialization in 2019.

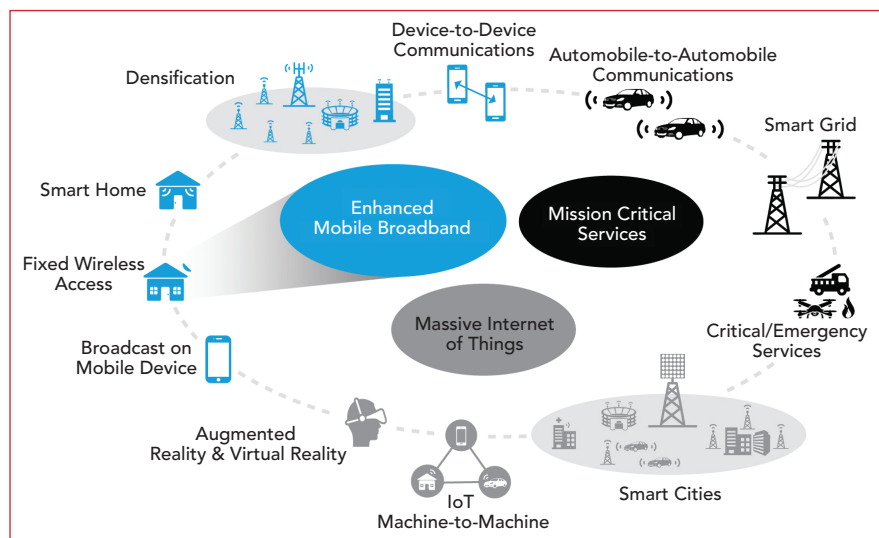

▲ Fig. 1 5G use cases.

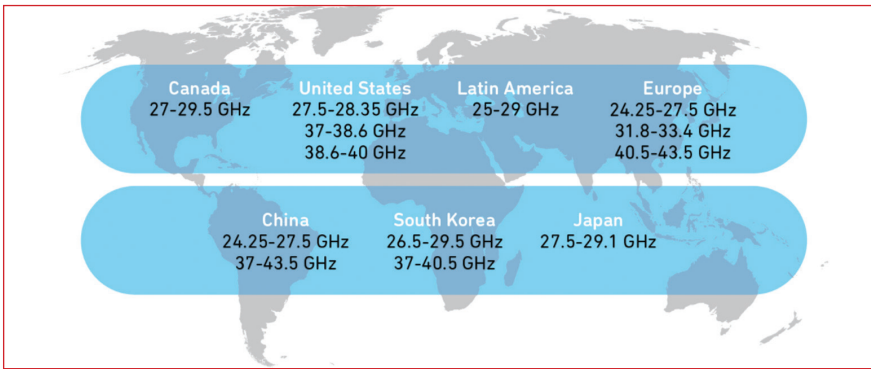

▲ Fig. 2 Global 5G bands above 24 GHz.

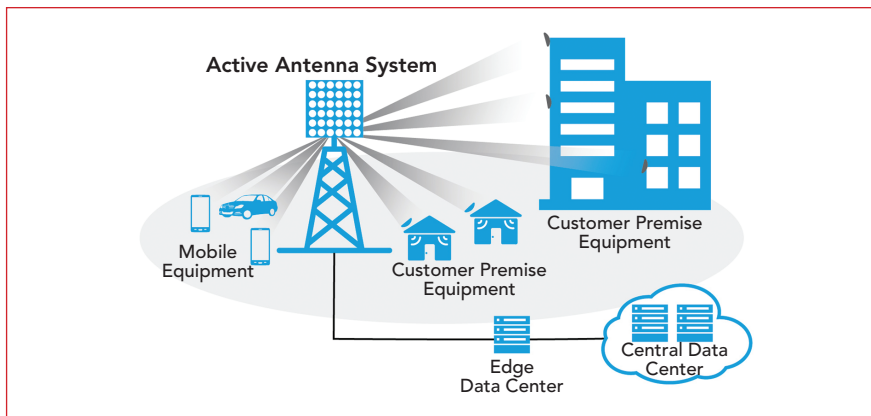

▲ Fig. 3 End-to-end FWA network.

In this article, we analyze the architecture, semiconductor technology and RF front-end (RFFE) design needed to deliver these new mmWave FWA services. We discuss the link budget requirements and walk through an example of suburban deployment. We address the traits and trade-offs of hybrid beamforming versus all-digital beamforming for the base transceiver station (BTS) and analyze the semiconductor technology and RFFE components that enable each. Finally, we discuss the design of a GaN-on-SiC front-end module (FEM) designed specifically for the 5G FWA market.

FWA DEPLOYMENT

A clear advantage of using mmWave is the availability of underutilized contiguous spectrum at low cost. These bands allow wide component carrier bandwidths up to 400 MHz and commercial BTSs are being designed with carrier aggregation supporting up to 1.2 GHz of instantaneous bandwidth. Customer premise equipment (CPE) will support peak rates over 2 Gbps

and come in several form factors: all outdoor, split-mount and all indoor desktop and dongle-type units. Mobile-handset form factors will follow.

Global mmWave spectrum availability is shown in **Figure 2**. In the U.S., most trials are in the old block A LMDS band between 27.5 and 28.35 GHz, but the plan-of-record of carriers is to deploy nationwide in the wider 39 GHz band, which is licensed on a larger economic area basis. These candidate bands have been assigned by 3GPP and, except for 28 GHz, are being harmonized globally by the International Telecommunications Union.²

FWA describes a wireless connection between a centralized sectorized BTS and numerous fixed or nomadic users (see **Figure 3**). Systems are being designed to leverage existing tower sites and support a low-cost, self-install CPE build-out. Both are critical to keeping initial deployment investment low while the business case for FWA is validated. Early deployments will be mostly outdoor-to-outdoor and use professional roof-level installa-

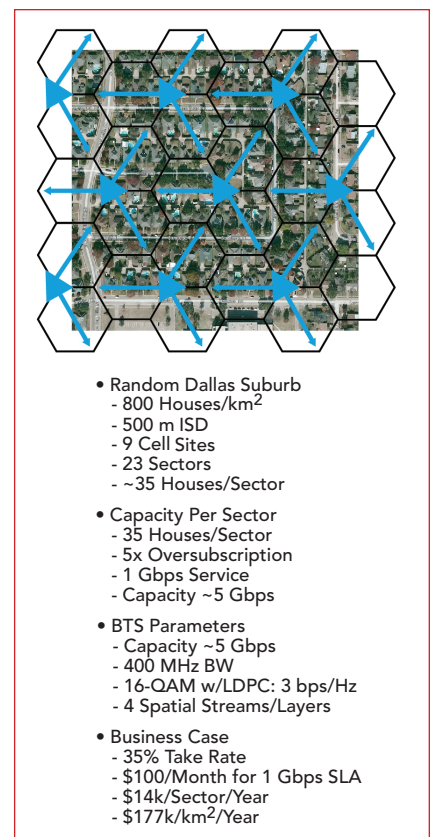

▲ Fig. 4 FWA in a suburban environment.

tions that maximize range, ensure initial customer satisfaction and allow time for BTS and CPE equipment to reach the needed cost and performance targets.

Large coverage is essential to the success of the FWA business case. To illustrate this, consider a suburban deployment with 800 homes/km², as shown in **Figure 4**. For BTS inter-site distance (ISD) of 500 m, we need at least 20 sectors, each covering 35 houses from nine cell sites. Assuming 33 percent of the customers sign up for 1 Gbps service and a 5x network oversubscription ratio, an average aggregate BTS capacity of 3 Gbps/sector is needed. This capacity is achieved with a 400 MHz bandwidth, assuming an average spectral efficiency of 2 bps/Hz and four layers of spatial multiplexing. If customers pay \$100 per month, the annual revenue will be \$280,000/km²/year. Of course, without accounting for recurring costs, it is not clear FWA is a good business, but we can conclude that as ISD increases, the business case improves. To that end, carriers are driving equipment vendors to

Equipment Class	Power (EIRP)
Base Station	75 dBm/100 MHz
Mobile Station	43 dBm
Transportable Station	55 dBm

build BTS and CPE equipment that operate up to regulatory limits to maximize coverage and profitability.

In the U.S., the Federal Communications Commission has defined very high effective isotropic radiated power (EIRP) limits for the 28 and 39 GHz bands,³ shown in **Table 1**. The challenge becomes building systems that meet these targets within the cost, size, weight and power budgets expected by carriers. Selecting the proper front-end architecture and RF semiconductor technology are key to getting there.

FWA Link Budget

The standards community has been busy defining the performance requirements and evaluating use cases over a broad range of mmWave frequencies. The urban-macro scenario is the best representation of a typical FWA deployment: having large ISD of 300 to 500 m and providing large path-loss budgets that overcome many of the propagation challenges at mmWave frequencies. To understand the needed link budget, consider a statistical path-loss simulation using detailed large-scale channel models that account for non-line-of-site conditions and outdoor-to-indoor penetration, like those defined by 3GPP⁴

Figure 5 shows the result for a 500 m ISD urban-macro environment performed by equipment vendors and operators. For this simulation, 28 GHz channel models were used with 80 percent of the randomly dropped users falling indoors and 20 percent outdoors. Of the indoor users, 50 percent were subject to high penetration-loss models and 50 percent lower loss. Long-term, carriers desire at least 80 percent of their potential users to be self-installable to minimize more expen-

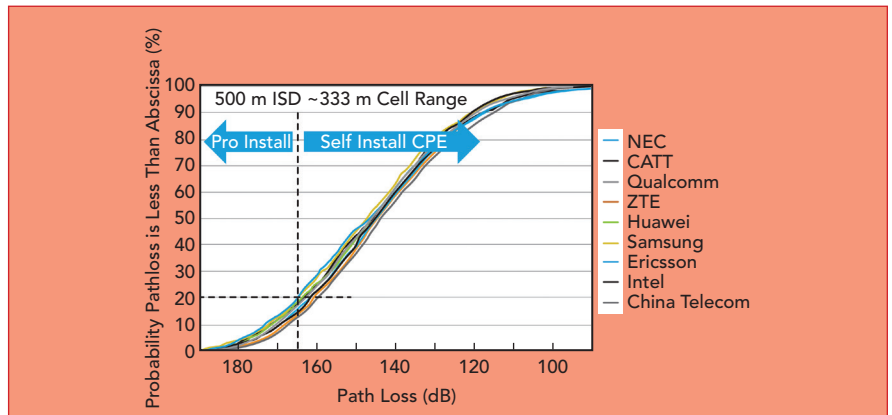

▲ Fig. 5 Statistical path loss simulation for urban-macro environment with 500 m ISD.

sive professional roof-level installations. The distribution curve shows the maximum system path loss to be 165 dB.

Closing the link depends on many variables, including transmit EIRP, receive antenna gain, receiver noise figure (NF) and minimum edge-of-coverage throughput. To avoid overdesign of the cost-sensitive CPE equipment and shift the burden toward the BTS, the link design begins at the CPE receiver and works backward to arrive at the BTS transmitter requirements. In lieu of the conventional G/T (the ratio of antenna gain to system noise temperature) figure-of-merit (FOM), we define a more convenient G/NF FOM: the peak antenna gain (including beamforming gain) normalized by the NF of the receiver. **Figure 6** illustrates the required EIRP for the range of receive G/NF to overcome a targeted path loss delivering an edge-of-coverage throughput of 1 Gbps, assuming the modulation spectral efficiency is effectively 2 bps/Hz and demodulation SNR is 8 dB. From the graph, the BTS EIRP for a range of CPE receiver's G/NF can be determined. For example, 65 dBm BTS EIRP will be needed to

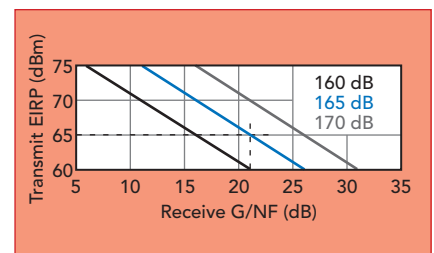

▲ Fig. 6 Transmit EIRP and receive G/NF vs. path-loss for 1 Gbps edge-of-coverage throughput.

sustain a 1 Gbps link at 165 dB of path loss when the CPE receiver G/NF is ≥ 21 dBi.

Next, we consider the impact of receiver NF by plotting the minimum number of array elements needed to achieve G/NF of 21 dB (see **Figure 7**). We also plot the total low noise amplifier (LNA) power consumption. By adjusting the axis range, we can overlap the two and see the impact NF has on array size, complexity and power. For this example, each LNA consumes 40 mW, which is typical for phased arrays. The NFs of RFFEs, including the T/R switch losses, are shown for 130 nm SiGe BiCMOS, 90 nm GaAs PHEMT and 150 nm GaN HEMT at 30 GHz. The compound semiconductor

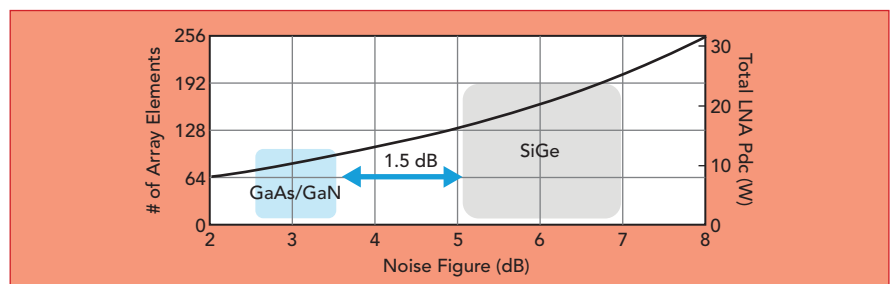

▲ Fig. 7 Array size vs. front-end NF and power consumption for G/NF = 21 dB.

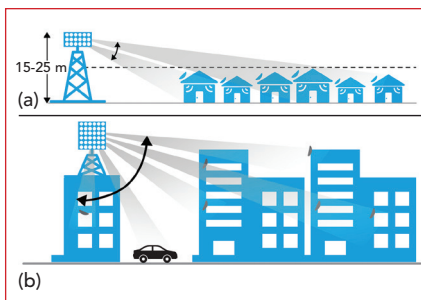

▲ Fig. 8 Array complexity depends on the scanning range needed for the deployment: suburban (a) or urban (b).

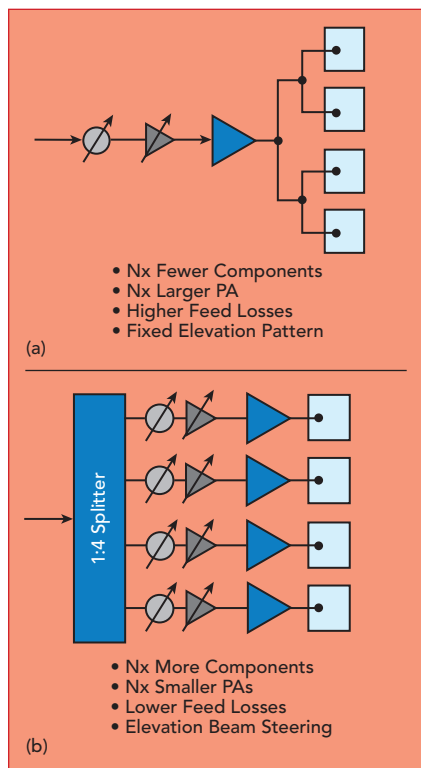

▲ Fig. 9 Column-fed (a) and per-element (b) active arrays.

technology provides ≥ 1.5 dB advantage, translating to a 30 percent savings in array size, power and, ultimately, CPE cost.

To explore architecture trades that are key to technology selection and design of the RFFE components, we start by understanding the antenna scanning requirements. We highlight the circuit density and packaging impact for integrated, dual-polarization receive/transmit arrays. Finally, we investigate all-digital beamforming and hybrid RF beamforming architectures and the requirements for each.

1D or 2D Scanning

The number of active channels in the array depends on many things.

Column Array Size	Beamwidth (°)	Gain (dB)
Single Element	102	5
2-Element	51	8
4-Element	26	11
8-Element	13	14

Let's start by first understanding the azimuth and elevation scanning requirements and whether two-dimensional beamforming is required for a typical FWA deployment or if a lower complexity, one-dimensional (azimuth only) beamforming array is sufficient. This decision impacts the power amplifier (PA). **Figure 8** shows two FWA deployment scenarios. In the suburban deployment, the tower heights range from 15 to 25 m and the cell radius is 500 to 1000 m, with an average house height of 10 m. Just as with traditional macro cellular systems, there is no need for fully adaptive elevation scanning. The elevation beam can be focused down by corporately feeding several passive antenna elements, as shown in **Figure 9a**. This vertically stacked column of radiating elements is designed to minimize radiation above the houses and fill in any nulls along the ground. Further, the gain pattern is designed to increase at relatively the same rate as the path loss. This provides more uniform coverage for both near and far users. The nominal half-power beamwidth can be approximated as $102^\circ/N_{ANT}$ and the array gain by $10\log_{10}(N_{ANT}) + 5$ dBi. With passively combined antennas, the elevation beam pattern is focused and the fixed antenna gain increases, as shown in **Table 2**. For the suburban FWA deployment, a 13 to 26 degree beamwidth is sufficient, with the passively combined column array from four to eight elements. In the urban scenario, however, the elevation scanning requirements are greater, and systems will be limited to one or two passive elements.

Figure 9b illustrates the per-element active array. Both the per-element and column-fed array architectures have the same antenna gain, but the column-fed array has a fixed elevation beam pattern. The

per-element array supports wider scan angles but needs 4x as many PAs, phase shifters and variable gain components for an antenna with four elements. To achieve the same EIRP, the PA driving a column-fed array with four antennas will need to provide at least 4x the output power, which can easily change the semiconductor selection. It is reasonable to assume a suburban BTS will use antennas with 6 to 9 dB higher passive antenna gain compared to an urban deployment. As a result, the phased array needs far fewer active channels to achieve the same EIRP, significantly reducing active component count and integration complexity.

Array Front-End Density

Early mmWave FWA BTS designs used separate, single-polarization transmit and receive antenna arrays, which allowed significantly more board area for components. These designs avoided the additional insertion loss and linearity challenges of a T/R switch. However, a major architecture trend is integrated T/R, dual-polarization arrays (see **Figure 10**), which is driving RFFE density. The key reason is spatial correlation. Adaptive beamforming performance depends on the ability to calibrate the receive and transmit arrays relative to one another. As such, it is important to integrate the transmit and receive channels for both polarizations, so the array shares a common set of antenna elements and RF paths. The net result is a requirement for the RFFE to have 4x the circuit density of earlier systems.

At mmWave frequencies, the lattice spacing between phased-array elements becomes small, e.g., 3.75 mm at 39 GHz. To minimize feed loss, it is important to locate the front-end components close to the radiating elements. Therefore, it

CoverFeature

is necessary to shrink the RFFE footprint and integrate multiple functions, either monolithically on the die or within the package, using a multi-chip module. Tiling all these functions in a small area requires either very small PAs, requiring a many-fold increase in array size, or using high-power density technologies like GaN. Further, it is critical to use a semiconductor technology that can withstand high junction temperatures. The reliability of SiGe degrades rapidly above 150°C, but GaN on SiC is rated to 225°C. This 75°C advantage in junction temperature has a large impact on the thermal design, especially for outdoor, passively-cooled phased arrays.

ALL-DIGITAL VS. HYBRID ARRAYS

It was natural for BTS vendors to first explore extending the current, sub-6 GHz, all-digital beamforming, massive MIMO platforms to mmWave. This preserves the basic architecture and the advanced signal processing algorithms for beamformed spatial multiplexing. However, due to the dramatic increase in channel bandwidths offered by mmWave and the need for many active channels, there is a valid concern that the power dissipation and cost of such a system would be prohibitive. Therefore, vendors are exploring hybrid beamformed architectures,⁵ which allows flexibility

between the number of baseband channels and the number of active RF channels. This approach better balances analog beamforming gain and baseband processing. The following sections analyze the two architectures and discuss the RFFE approaches needed for each.

Digital Beamforming

Assuming large elevation scanning is not required for suburban FWA and a well-designed, column antenna provides gain of up to 14 dBi, we start with a mmWave BTS transceiver design targeting an EIRP of 65 dBm and compute the power consumption using off-the-shelf point-to-point microwave radio

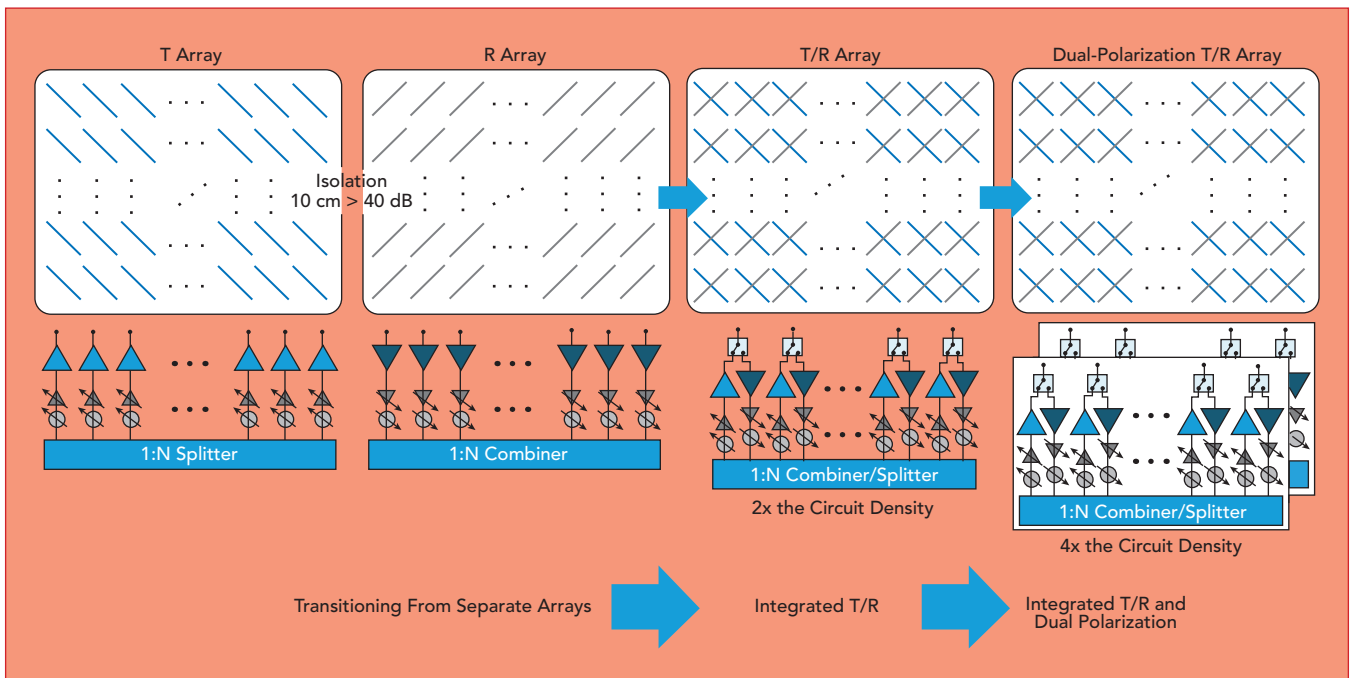

▲ Fig. 10 FWA antenna arrays are evolving from separate T and R arrays to integrated T/R arrays with dual polarization.

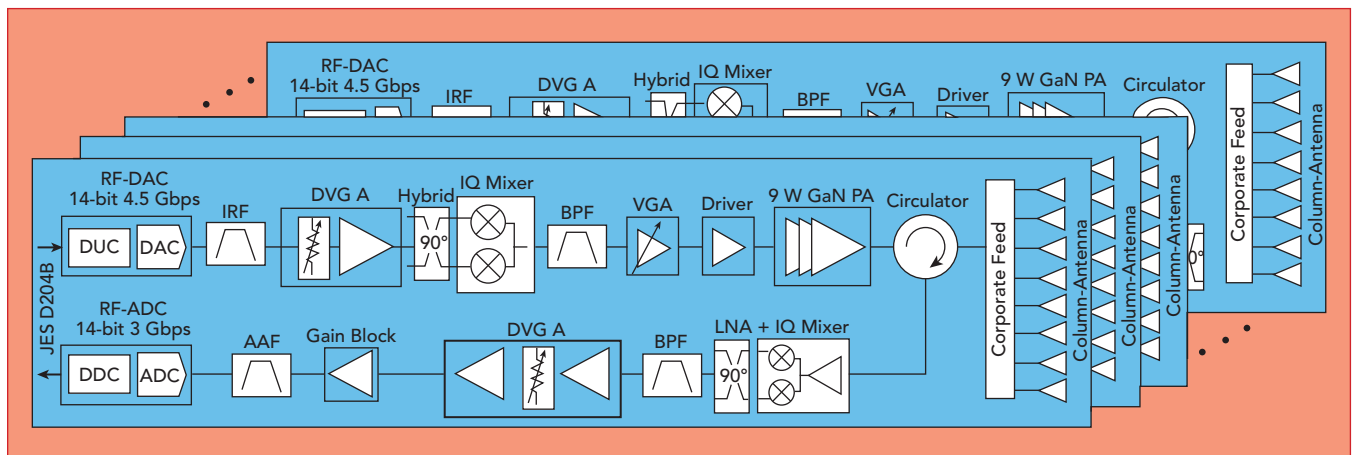

▲ Fig. 11 Array design using digital beamforming and commercial, off-the-shelf components.

CoverFeature

components that have been available for years, including a high-power, 28 GHz GaN balanced amplifier. The multi-slat array and transceiver are shown in **Figure 11**. Assuming circulator and feed-losses of 1.5 dB, the power at the antenna port is 27 dBm. From the following equations, achieving 65 dBm EIRP requires 16 transceivers that, combined, provide 12 dB of digital beamforming gain:

$$\text{EIRP} = G_{\text{BF}} (\text{dB}) + G_{\text{ANT}} (\text{dBi}) + P_{\text{AVE_TOTAL}} (\text{dBm})$$

$$\text{EIRP} = 10 \log_{10}(N_{\text{COLUMNS}}) + 10 \log_{10}(N_{\text{PAS}}) + G_{\text{ANT}} + P_{\text{AVE/CHANNEL}} (\text{dBm})$$

The power consumption for each transceiver is shown in **Figure 12**. The total power dissipation (P_{DISS}) at 80 percent transmit duty cycle for all 16 slats will be 220 W per polarization, and a dual-polarized system will require 440 W. For all outdoor tower-top electronics, where passive cooling is required, it is challenging to thermally manage more than 300 W from the RF subsystem, suggesting an all-digital beamforming architecture using today's off-the-shelf components is impractical.

However, new GaN FEMs are on the horizon to help address this. As shown in **Figure 13**, the GaN PAs integrated in the FEM apply the tried-and-true Doherty efficiency-boosting technique to mmWave. With Doherty PAs, digital pre-distortion (DPD) is needed; however, the adjacent channel power ratio (ACPR) requirements defined for mmWave bands are significantly more relaxed, enabling a much "lighter" DPD solution. The estimated power dissipation of a 40 dBm P_{SAT} , symmetric, multi-stage Doherty PA can be reduced more than 50 percent. In the above system, this improvement alone drops the total P_{DISS} below 300 W. Combined with power savings from next-generation RF-sampling digital-to-analog and analog-to-digital converters, advancement in mmWave CMOS transceivers and increased levels of small-signal integration, it will not be long before we see more all-digital beamforming solutions being deployed.

Hybrid Beamforming

The basic block diagram for a hybrid beamforming active array is shown in **Figure 14**. Here, N baseband channels are driving RF analog beamformers, which divide the signal M -ways and provide discrete phase and amplitude control. FEMs drive each M -element subarray panel. The number of baseband paths and subarray panels is determined by the minimum number of spatial streams or beams that are needed. The number of beamformer branches and elements in each subarray panel is a function of the targeted EIRP and G/NF . While a popular design ratio is to have one baseband path for every 16 to 64 active elements, it really depends on the deployment scenario. For example, with a hot-spot small cell (or on the CPE terminal side), a 1:16 ratio single panel is appropriate. A macro BTS would have two to four subarray panels with 64 active elements, where each panel is dual-polarized, totaling four to eight baseband paths and 256 to 512 active elements. The digital and analog beamforming work together, to maximize coverage or independently, to provide spatially separated beams to multiple users.

There is an important trade unfolding, whether SiGe front-ends can provide sufficient output power and efficiency to avoid the need for higher performance III-V technology like GaAs or GaN. With good packaging and integration, both approaches can meet the tight antenna lattice-spacing requirements.

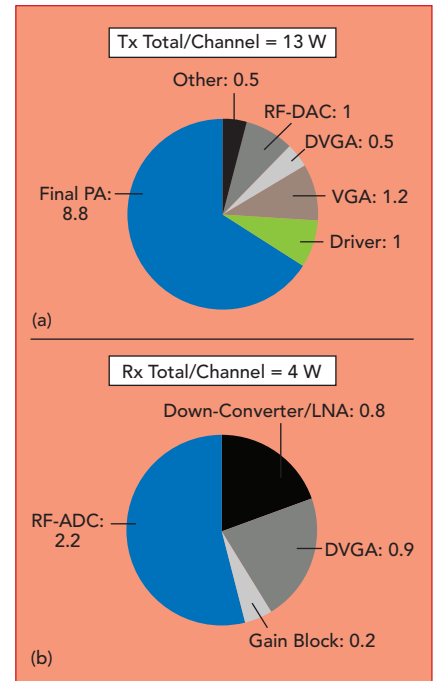

▲ **Fig. 12** Power dissipation of the transmit (a) and receive (b) chains.

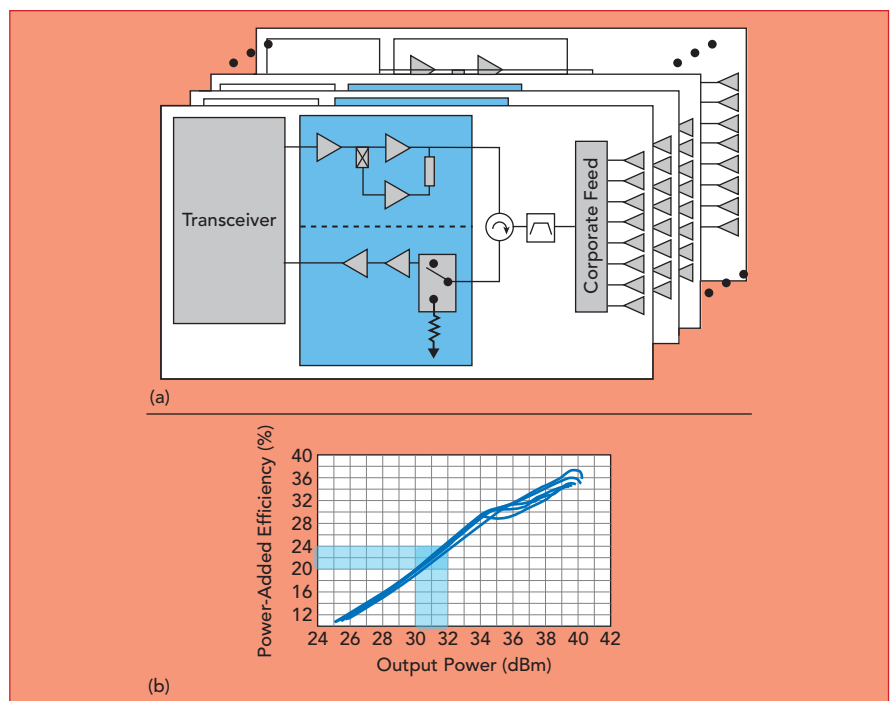

▲ **Fig. 13** Integrated FEM with symmetric GaN Doherty PA and switch-LNA (a) and PA performance from 27.5 to 29.5 GHz (b).

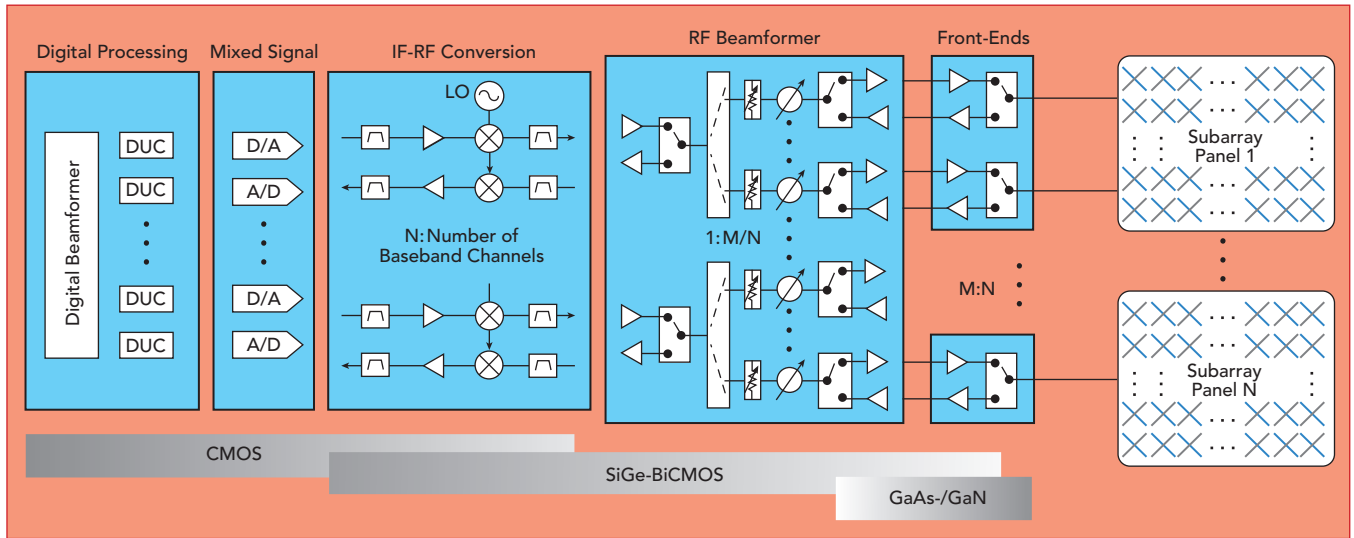

▲ Fig. 14 Active array using hybrid beamforming.

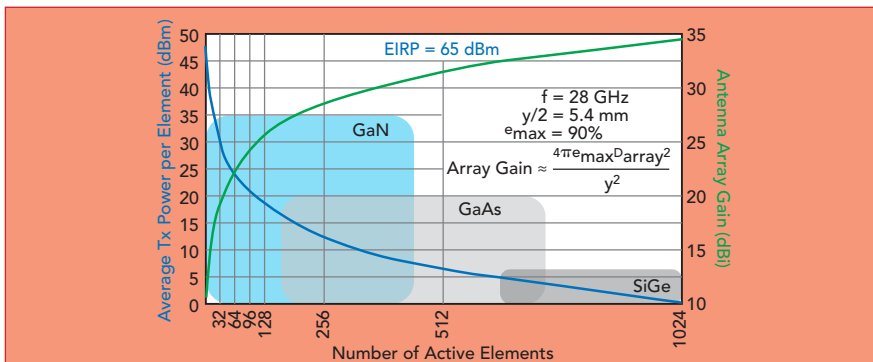

▲ Fig. 15 Optimum RFFE technology vs. array size.

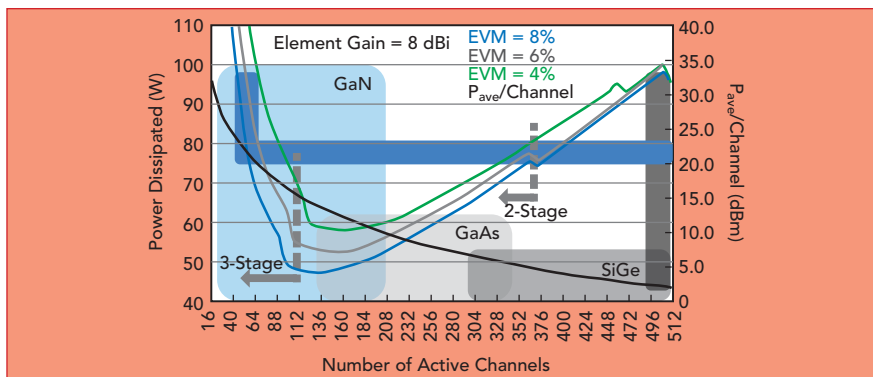

▲ Fig. 16 System power dissipation vs. array size and EVM for 64 dBm EIRP.

FRONT-END SEMICONDUCTOR CHOICES

The technology choice for the RFFE depends on the EIRP and G/NF requirements of the system. Both are a function of beamforming gain, which is a function of the array size. To illustrate this, **Figure 15** shows the average PA power (P_{AVE}) per channel needed as a function

of array size and antenna gain for a uniform rectangular array delivering 65 dBm EIRP. The graph is overlaid with an indication of the power ranges best suited for each semiconductor technology. The limits were set based on benchmarks of each technology, avoiding exotic power-combining or methods that degrade component reliability or efficiency.

As array size gets large (more than 512 active elements), the power per element becomes small enough to allow SiGe, which can be integrated into the core beamformer RFIC. In contrast, by using GaN for the front-end, the same EIRP can be achieved with 8 to 16x fewer channels.

System Power Dissipation

For an array delivering 64 dBm EIRP, **Figure 16** shows an analysis of the total P_{DISS} of the beamformer plus the front-end as a function of the number of active elements in each subarray panel. The P_{DISS} is shown for several error vector magnitude (EVM) levels, since the EVM determines the power back-off and efficiency achieved by the front-end. We assume each beamformer branch consumes 190 mW, which is the typical power consumption of core beamformers in the market.⁶ The system on the far right of the figure represents an all-SiGe solution with 512 elements, with an output power per element of 2 dBm and consuming approximately 100 W. Moving left, the number of elements decreases, the P_{AVE} per channel increases and P_{DISS} is optimized to a point where beamforming gain starts to roll off sharply, and the P_{DISS} to maintain the EIRP rapidly increases. The small steps in the dissipation curves represent where the front-end transitions from a single stage to two-stage and three-stage designs to provide sufficient gain. As stages are added, the efficiency

TABLE 3

RELATIVE COST OF ALL SiGe AND SiGe BEAMFORMER WITH GaN FEM

Parameter	Units	All SiGe	GaN +SiGe
Average Output Power per Channel	dBm	2	20
Power Dissipation per Channel	mW	190	1329
Antenna Element Gain	dBi	8	8
Number of Active Channels		512	64
EIRP	dBmi	64	64
Total Power Dissipation	W	97	97
Beamformer Die Area per Channel	mm ²	2.3	2.3
Front-End Die Area per Channel	mm ²	1.2	5.2
Total SiGe Die Area	mm ²	1752	144
Total GaN Die Area	mm ²	0	334
	Die Cost	Units	Notes
All SiGe System Die Cost	1752	\$/x	
GaN + SiGe System Die Cost (4-inch GaN)	1647	\$/x	4-inch GaN = 4.5x
GaN + SiGe System Die Cost (6-inch GaN)	1146	\$/x	6-inch GaN = 3x

drops with the increase in power dissipation.

Designing to optimize system P_{DISS} without regarding complexity or cost, an array of about 128 elements with a two-stage, 14 dBm output PA (24 dBm P_{1dB}) is the best choice. However, if we strive to optimize cost, complexity and yield for a P_{DISS} budget of under 100 W, the optimum selection is the range of 48 to 64 active channels using a three-stage GaN PA with an average output power of 20 to 23 dBm, depending on the EVM target. The trends shown in Figure 16 are less a function of PA efficiency and more a function of beamformer inefficiency. In other words, the choice to increase array size 8x to allow an all-SiGe solution comes with a penalty, given that the input signal is divided many more ways and requires linearly biased, power consuming devices to amplify the signal back up.

Cost Analysis

The cost of phased arrays include the RF components, printed circuit board material and the antennas

themselves. Using compound semiconductor front-ends allows an immediate 8x reduction in array size with no increase in P_{DISS} . Even with lower-cost printed antenna technology, this is a large saving in expensive antenna-quality substrate material. Considering component cost, the current die cost per mm² of 150 nm GaN on SiC fabricated on 4-inch wafers is only 4.5x the cost of 8-inch 130 nm SiGe. As 6-inch GaN production lines shift into high volume, the cost of GaN relative to SiGe drops to 3x. A summary of the assumptions and a cost comparison of the relative raw die cost of the two technologies is shown in **Table 3**. Using a high-power density compound semiconductor like GaN on 6-inch wafers can save up to 35 percent in the raw die cost relative to an all-SiGe architecture. Even though the cost of silicon technologies is lower per device, the cost of the complete system is significantly higher.

GaN FRONT-END MODULES

To validate the concept of a GaN FEM for mmWave FWA arrays, Qorvo set out to design the highest power,

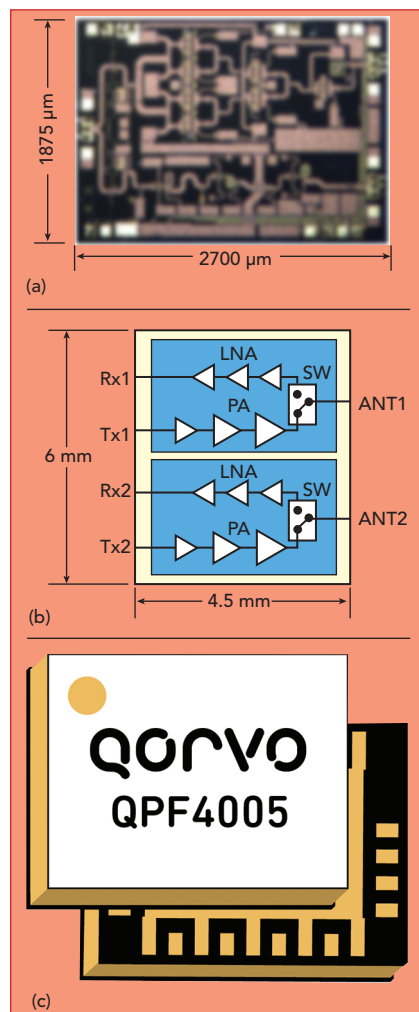

▲ Fig. 17 Integrated 39 GHz GaN front-end MMIC – intentionally blurred (a), dual-channel FEM (b) and package (c).

lowest NF FEM for the 37 to 40 GHz band. To support the trend to integrated transmit/receive arrays, the front-end includes a PA, integrated T/R switch and a low NF LNA. The module was designed with sufficient gain to be driven by core beamformer RFICs, which have a typical drive level of 2 dBm. The FEM's P_{AVE} of 23 dBm was selected from an analysis similar to that shown in Figure 16, and the P_{SAT} was determined by analyzing the needed headroom to support a back-off linearity of ≥ 33 dBc ACPR, EVM ≤ 4 percent and a 400 MHz orthogonal frequency-division multiple access (OFDMA) waveform.

A key design decision was determining if GaAs or GaN or a combination of both were needed. The die size for a GaAs PA would not allow the FEM to meet the tight 3.75 mm lattice spacing at 39 GHz. The

equivalent output power GaN PA is 4x smaller with no sacrifice in gain and a slight benefit in efficiency. Considering the LNA, the 90 nm GaAs PHEMT process was favored due to its slightly superior NF. However, the net improvement was only a few tenths of a dB once the additional bond wires and 50 Ω matching networks were considered. The trade-off analysis concluded it was better to stay with a monolithic GaN design that allowed co-matching of the PA, LNA and T/R switch. Such a design was lower risk, easier to assemble and test, and the MMIC was as compact as possible. The system thermal analysis indicated that the higher junction temperature offered by GaN-on-SiC was critical for passively-cooled arrays.

As shown in **Figure 17**, the 39 GHz FEM integrates two of the multi-function GaN MMICs into an air-cavity, embedded heat-slug, surface-mount package, sized to meet the array element spacing at 39 GHz. Each of the GaN MMICs contains a three-stage linear PA, three-stage LNA and a low-loss, high-linearity SPDT switch. The FEM covers 37.1 to 40.5 GHz and provides 23 dBm average output power, which supports 256-QAM EVM levels, with 24 dB transmit

gain. In receive mode, the NF is 4.1 dB, and receive gain is 16 dB. The package size is 4.5 mm \times 6.0 mm \times 1.8 mm.⁷⁻⁸

SUMMARY

FWA is rapidly approaching commercialization. This is due to the abundance of low-cost spectrum, early regulatory and standards work and the opportunity for operators to quickly tap a new market. The remaining challenge is the availability of equipment capable of closing the link at a reasonable cost. Both hybrid beamforming and all-digital beamforming architectures are being explored. These architectures capitalize on the respective strengths of commercial semiconductor processes. The use of GaN front-ends in either approach provides operators and manufacturers a pathway to achieving high EIRP targets while minimizing cost, complexity, size and power dissipation. To prove the feasibility, Qorvo has developed a 39 GHz FEM based on a highly integrated GaN-on-SiC T/R MMIC and is developing similar FEMs for other millimeter wave frequency bands proposed for 5G systems. ■

References

1. International Telecommunications Union, ITU-R Radiocommunications Sector of ITU, "IMT

Vision—Framework and Overall Objectives of the Future Development of IMT for 2020 and Beyond," August 2015, www.itu.int/dms_pubrec/itu-r/rec/m/R-REC-M.2083-0-201509-1!!PDF-E.pdf.

2. International Telecommunications Union, Resolution 238 (WRC-15), "Studies on Frequency-Related Matters for International Mobile Telecommunications Identification Including Possible Additional Allocations to the Mobile Services on a Primary Basis in Portion(s) of the Frequency Range 24.25 and 86 GHz for Future Development of IMT-2020 and Beyond," 2015, www.itu.int/dms_pub/itu-r/oth/0c/0a/R0C0A00000C0014PDFE.pdf.
3. Federal Communications Commission, "Use of Spectrum Bands Above 24 GHz for Mobile Radio Services, In the Matter of GN Docket No. 14-177, IB Docket No. 15-256, RM-11664, WT Docket No. 10-112, IB Docket No. 97-95," July 2016, apps.fcc.gov/edocs_public/attachmatch/FCC-16-89A1.pdf.
4. 3GPP TR 38.901, "Study on Channel Model for Frequencies from 0.5 to 100 GHz," September 2017, www.3gpp.org/ftp/Specs/archive/38_series/38.901/38901-e20.zip.
5. A. F. Molisch et al., "Hybrid Beamforming for Massive MIMO: A Survey," *IEEE Communications Magazine*, Vol. 55, No. 9, 2017, pp. 134–141.
6. B. Sadhu et al., "7.2 A 28GHz 32-Element Phased-Array Transceiver IC with Concurrent Dual Polarized Beams and 1.4 Degree Beam-steering Resolution for 5G Communication," *2017 IEEE International Solid-State Circuits Conference (ISSCC)*, San Francisco, Calif, 2017, pp. 128–129.
7. B. Kim and V. Z. Q. Li, "39 GHz GaN Front-End MMIC for 5G Applications," *2017 IEEE Compound Semiconductor Integrated Circuit Symposium (CSICS)*, Miami, Fla., 2017, pp. 1–4.
8. "QPF4005 37-40.5 GaN Dual Channel FEM Datasheet," www.qorvo.com/products/d/da006271.