

How to Increase Downstream Bandwidth and Upstream Capabilities in CATV Amplifiers with Greater Efficiency

By Rainer Hillermeier

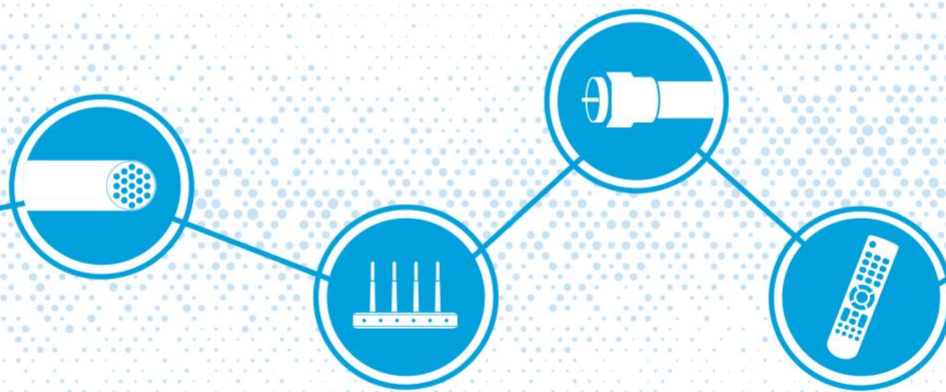

Staying relevant in the CATV market can be challenging with fast-changing standards and regulations. Hybrid fiber coaxial (HFC) networks worldwide are being upgraded to DOCSIS® 3.1 (data over cable service interface specification) with a mid- or high-split to enable increasing data speed and capacity for upstream and downstream traffic. Concurrently, the next generation, DOCSIS 4.0, spec is recently released advocating the development and optimization of components to continue to prepare for the future deployment. Even though volume production of DOCSIS 4.0 products is still a few years out, the development and optimization of components and definition of networks began several years ago.

DOCSIS 3.1 is bringing the industry up from 1 GHz, 870 MHz, or maybe even only 750 MHz to 1.2 GHz, and DOCSIS 4.0 increases frequencies to 1.8 GHz. This evolution is necessary to accommodate the growing need for higher upstream data rates.

Today more people are working from home than ever before. While this has certainly highlighted the need for greater upstream communication across broadband networks, a remote workforce is not the only major driver for upstream demand. We are on the cusp of a new wave of interactive entertainment in which viewers are not passive watchers but active participants. Consider how sports are poised to change: viewers will be able to interact with their friends not just over chat but through livestreaming video. Viewers will also be able to make real-time “microbets” during a game. These bets will go far beyond who will win, enabling players to wager on a wide range of dynamic factors throughout the game, such as who will score next.

And this is just one application needing greater upstream capacity beside general interactive entertainment, gaming, smart home applications and others. To keep their customer base satisfied, providers simply need more bandwidth.

Extending Bandwidth

In the USA, HFC networks commonly allocates 5 MHz to 42 MHz for upstream traffic. As users continue to put a greater strain on the available bandwidth, the upstream data rates become the limiting factor in the performance of the network. There simply is not enough upstream capacity to support more data for each user.

To meet higher uplink bandwidth demand, multiple system operators (MSO) are considering increasing the upstream to a mid-split, with a bandwidth from 5 MHz to 85 MHz, or a high split, with 5 MHz to 204 MHz. The DOCSIS 4.0 specification provides for splits at 300 MHz, 396 MHz, 492 MHz, or even 684 MHz (**Figure 1**). Increasing upstream bandwidth, however, could mean reducing downstream bandwidth and cutting contents or services. To avoid reducing the downstream bandwidth while increasing the upstream, MSOs will take full advantage of the DOCSIS 3.1 or DOCSIS 4.0 specifications. When upgrading the upstream, they will push the downstream to higher frequencies. DOCSIS 3.1 will allow MSOs to extend to 1.2 GHz and DOCSIS 4.0 is utilizing two options: full duplex (FDX), where upstream and downstream share the same frequency range to 684 MHz (**Figure 2**) or extended spectrum DOCSIS (ESD), where the upper frequency is extended up to 1.8 GHz.

Figure 1. DOCSIS 4.0 ESD spectrum and splits between upstream (US) and downstream (DS).

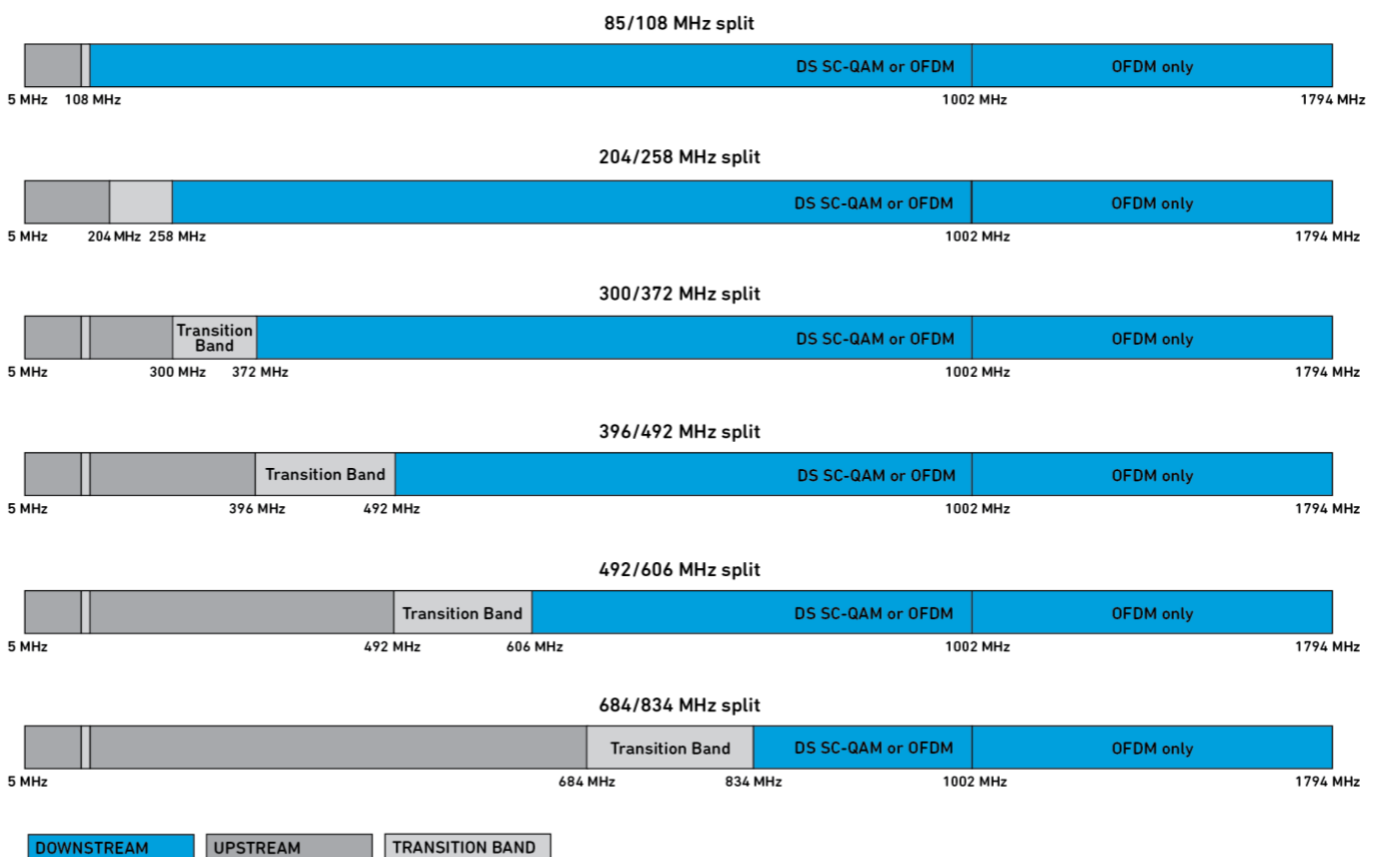
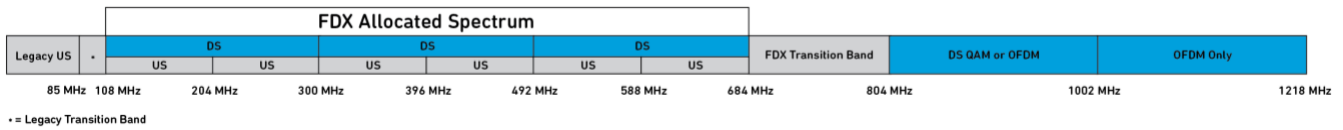

Figure 2. DOCSIS 4.0 FDX spectrum for upstream (US) and downstream (DS).



© 2021 Qorvo US, Inc.

MSOs considering the migration to DOCSIS 3.1 would do well to consider how and when they will manage the transition to DOCSIS 4.0. Again, remote working has pressed the limits of existing infrastructure, and it is more than likely that this demand will continue to go up over the next few years.

There is a common understanding in the industry that network upgrades are required to enable the higher bandwidth and data rates. To realize this an entire new portfolio of passive and active products is required. For the active equipment this means the systems need amplifiers with higher linear output power to maintain legacy levels in the HFC network up to 1 GHz but transmit additional channels up to 1.2 GHz or even 1.8 GHz (Figure 3). In summary, to increase bandwidth and data rates, the CATV amplifier needs a higher linear output power.

Figure 3. GaN is a key enabling technology for creating power amplifiers that meet DOCSIS standard requirements and exceed in efficiency and performance.

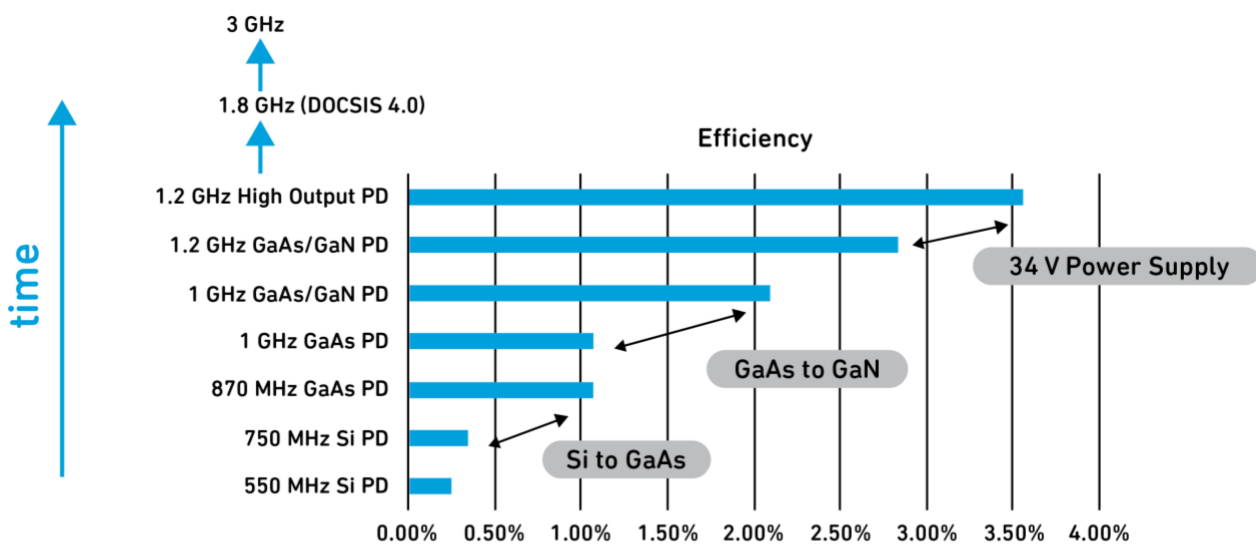

© 2021 Qorvo US, Inc.

Why Linearity?

The purpose of an HFC network is to transmit data from a headend to the user's cable modem for downstream and back to the headend for upstream. The data is transmitted by modulated single-carrier channels and with DOCSIS 3.1 by channels using orthogonal frequency division multiplexing (OFDM) loaded in the available bandwidth spectrum. The amplifiers in the HFC plant are amplifying the signal to compensate for the cable losses. At the end of the cable, the signal quality must be good enough to demodulate the signal without errors.

Nonlinearities of active devices like gain blocks degrade the signal quality. In the past, this distortion was visible when watching analog TV channels. One channel was influenced and distorted by the other TV channels. Today, for digital channels, bit errors occur, or the signal cannot be demodulated at all. For OFDM channels, it may mean that lower modulation rates need to be selected to transmit the signal at reduced data rates. In other words, the better the linearity of a gain block or amplifier, the better the signal quality and the higher the achievable data rates in the network.

The linearity of a gain block or amplifier depends on various factors including semiconductor technology, circuit design, power consumption, and thermal design. All these factors need to be considered and optimized to meet the data rate requirements when adding channels with wider and wider bandwidths.

The GaN Advantage

Linearity and efficiency are the major considerations in the design of a HFC amplifier (**Figure 4**). With greater efficiency, an amplifier can provide higher linear output power at the same DC power consumption. This allows designers to achieve wider bandwidths and higher data rates, extend the distance between amplifiers for longer runs, and maximize reliability. The downstream performance especially in respect to linear output power of a HFC amplifier or node is depending on the performance of the output stage gain block or the so-called power doubler. Therefore, it makes sense to have a closer look at these components.

Figure 4. A simplified block diagram of a CATV amplifier.

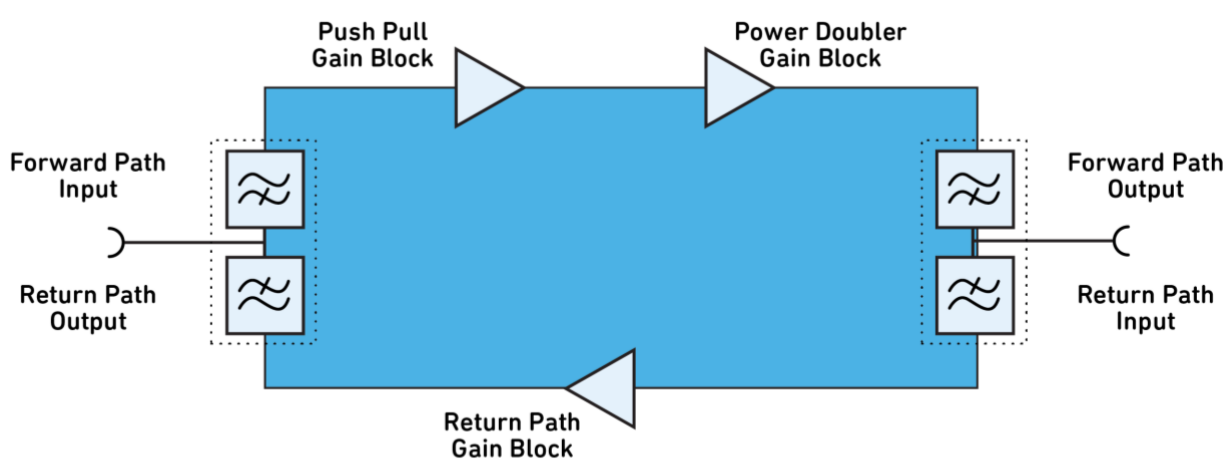

One of the initial evolutionary steps for gain blocks was the transition from silicon (Si) to gallium arsenide (GaAs) semiconductors. The higher electron mobility of GaAs allows it to achieve higher frequencies and bandwidths. Additionally, the FET-based design of GaAs transistors enables their assembly directly on the heatsink and therefore a superior thermal design, compared with Si bipolar transistors, which require an isolating layer. Finally, a GaAs FET-based design has lower third-order distortion because of its square law property: $I_D = I_{DSS} \times (1 - V_{gs}/V_p)^2$.

The next major technology leap was gallium nitride (GaN). GaN is a key enabling technology for creating power amplifiers that meet DOCSIS 3.1 and DOCSIS 4.0 standard requirements and excel in efficiency and performance. GaN, compared at the same power as other technologies, also provides higher reliability and longer operating life.

Figure 5. FET-based GaAs technology changed the gain block architecture. With the availability of GaN-based technology, this existing architecture can be improved upon by replacing FET3 and FET4 with GaN-based components.

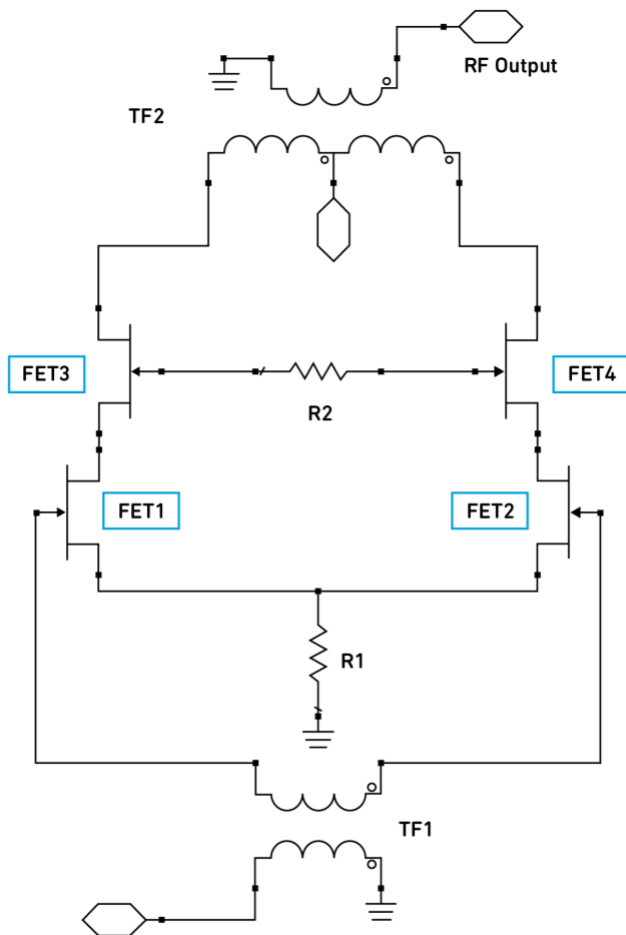

Figure 5 shows the simplified schematic of a CATV gain block. It employs two cascodes in a push-pull configuration (balanced design) to cancel second-order distortion and to enable a multi-octave bandwidth. FET-based GaAs technology changed the industry when it became available for such topologies and is still used for state-of-the-art CATV gain block amplifiers today. With the availability of GaN-based technology, this existing architecture can be improved upon by replacing FET3 and FET4 with GaN-based components. While the architecture remains the same, the performance of the system is improved significantly, taking advantage of the intrinsic technology properties of GaN.

GaN technology is continuing to evolve. At Qorvo, both GaAs and GaN technology are two of the core technologies developed and manufactured inhouse. This enables Qorvo PA designers to take advantage of the latest evolution of GaAs- and GaN-based semiconductors that are constantly optimized to meet and exceed the demanding challenges of wider bandwidths and higher linear output required for DOCSIS 3.1 and DOCSIS 4.0.

As Figure 6 shows, GaN-based gain blocks offer superior performance to Si and GaAs. Si gain blocks support high frequencies in specific configurations but do not provide high-voltage ruggedness or high current density. GaAs, for its part, can operate at high frequencies but fails to provide the high-voltage ruggedness or the required high current density.

GaN, however, can operate at high frequencies and deliver high-voltage ruggedness, high current density, and sufficient thermal conductivity and power handling. GaN achieves this through its higher power density – GaN supports up to 10 W/mm, compared with only 1 W/mm for GaAs. The smaller geometry of GaN lowers device capacitances, enabling higher bandwidths, and offers lower losses that result in superior gain and efficiency.

Figure 6. Characteristics of different material technologies used in CATV gain blocks. Parameters for GaN-on-SiC semiconductors highlighted in blue.

| Property | Si | GaAs | SiC | GaN | Benefits |
|---|------|------|-----|------|--------------------------------------|
| Energy Gap [eV] | 1.11 | 1.43 | 3.2 | 3.4 | High Voltage, Ruggedness |
| Charge Density ($1 \times 10^{13}/\text{cm}^2$) | 0.3 | 0.3 | 0.4 | 1 | High Current Density, Power Handling |
| Thermal Conductivity (W/cmK) | 1.5 | 0.5 | 3.3 | 1.5 | |
| Mobility (cm^2/Vs) | 1300 | 6000 | 600 | 1500 | High Frequency |



© 2021 Qorvo US, Inc.

There are various substrate materials available to manufacture GaN semiconductors. Qorvo uses gallium-nitride-on-silicon-carbide (GaN-on-SiC) substrate because this technology enables an optimal thermal conductivity and provides high reliability, on the order of 1×10^6 mean time to failure (MTTF). This reliability derives from the higher power-density capability and ability to operate at a higher channel temperature. This means, GaN-on-SiC-based gain blocks can dissipate more power without raising device temperature adversely. In terms of thermal conductivity, GaAs offers the poorest performance at ~ 0.5 W/cm-K, with Si coming in at only ~ 1.5 W/cm-K. In contrast, GaN-on-SiC has a significantly higher thermal conductivity, on the order of ~ 3.3 W/cm-K.

In summary, the advantages of GaN technology enable MSOs to increase linear output power while maintaining existing amplifier spacing. This, in turn, minimizes upgrade costs and enables the implementation of fiber deep solutions, whereby MSO can move fiber closer to customers for better service while reducing or eliminating amplifiers. This approach increases potential data rates to homes while reducing power consumption and maintenance costs. Altogether, these features make GaN an ideal technology for CATV gain blocks as output stages in HFC amplifier designs.

Production Manufacturing and Testing

Qorvo is the market leader for CATV gain blocks and is at the forefront of driving innovation to meet the needs of the HFC market. Qorvo was the first to introduce CATV gain blocks using GaN-on-SiC. That quickly became the preferred technology for high performance. To-date, Qorvo shipped more than 20 million GaN devices.

Qorvo offers a complete portfolio of RF solutions for DOCSIS 3.0, DOCSIS 3.1, and DOCSIS 4.0. Leveraging on extensive experience and technical expertise, Qorvo provides the support that can accelerate designs, manufacturing, and testing process.

The latest flagship product for high-power fiber deep applications for DOCSIS 3.1 and FDX DOCSIS 4.0 networks is the **QPA3260 power doubler hybrid**, which provides the highest linear output power up to 1.2 GHz. For DOCSIS 4.0, the **QPA3315 power doubler hybrid** is the equivalent for applications needing to support 1.8 GHz. Both the QPA3260 and QPA3315 provide 23 dB gain with industry-leading linearity. As described in this paper, linearity and a careful thermal design are extremely important for maximizing efficiency. Therefore, the thermal design and the related assembly and packaging technology also have a direct impact on reliability and ruggedness, especially during manufacturing, testing, and operation in the field.



Qorvo also brings a dedicated state of the art manufacturing operation that provides the high volumes HFC equipment manufacturers need in a timely fashion. To ensure a proper thermal design, Qorvo utilizes state-of-the-art assembly and package techniques, solder, and epoxy connections within an automated assembly line. Automation is the key for producing multi-million pieces each year, with the quality and reliability required for the CATV market. Through automation, Qorvo can auto-laser-trim and tune components to guarantee the minimum possible part-to-part variation as well as ensure reliable and reproducible performance.

Qorvo understands that the testing of CATV systems is very product specific. Developing a testing approach can be complex, comprehensive, and time-consuming, as testing stations must be defined, specified, and implemented to provide the right kind of testing.

To further guarantee consistent quality and reliability, Qorvo implements small signal and distortion testing across 100% of its CATV gain block production. Additionally, testing includes multi-carrier (composite) distortion testing with legacy analog loading or state-of-the-art digital loadings with single-carrier-QAM or OFDM channels. In this way, equipment manufacturers can rely on the fact that gain block components have been characterized and tested properly.

Qorvo has served HFC equipment manufacturers for over 25 years and works with its customers to set standards for testing that align with their specific needs. Qorvo also assists HFC equipment manufacturers in translating DOCSIS and application requirements to create their own testing stations that assure performance, reliability, and ruggedness.

DOCSIS 3.1 and DOCSIS 4.0 bring greater bandwidth and increased upstream capacity to help MSOs meet the evolving needs of their customers. With GaN-based gain blocks, CATV equipment manufacturers can confidently provide reliable systems and improve overall ruggedness and linear output power to enable the better transport of data.

[Learn more](#) about how Qorvo delivers consistent quality and reliability.

About the Author



Rainer Hillermeier

General Manager, Design and Operations – Qorvo Germany

Rainer manages Qorvo's Design and Manufacturing Site in Nuremberg, Germany. He has more than two decades of experience in designing high power CATV gain blocks. Under his guidance, the first 1 GHz, 1.2 GHz and now 1.8 GHz gain blocks were developed and released. He also pioneered the introduction of GaN semiconductor technology in hybrid fiber-coax infrastructure products.