



TGL2209–SM

8–12 GHz 50 Watt VPIN Limiter

Product Overview

The Qorvo TGL2209–SM is a high-power Monolithic Microwave Integrated Circuit, X-band GaAs VPIN limiter capable of protecting sensitive receive channel components against high power incident signals. The TGL2209–SM does not require DC bias and achieves a low insertion loss in a small form factor. These features allow for simple integration with minimal impact to system performance.

The TGL2209–SM operates from 8.0–12 GHz with low insertion loss of less than 0.5 dB. Receive protection is rated up to 50 W incident pulsed-power with a low flat leakage of less than 18.5 dBm.

The TGL2209–SM is offered as a packaged limiter and is well suited for both commercial and defense related applications.

Functional Block Diagram

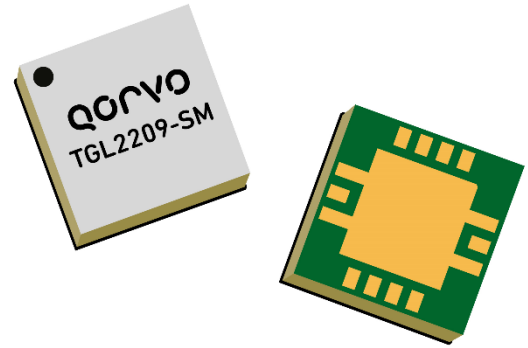
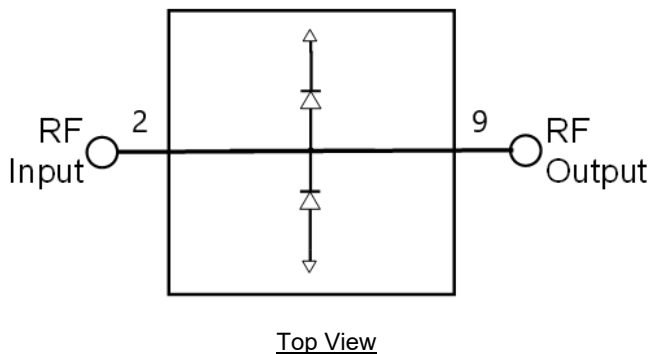

14 Pad 4 x 4 mm QFN Package

Key Features

- Frequency Range: 8.0 to 12.0 GHz
- Insertion Loss: < 0.5 dB
- Peak Power Handling: 50 W (pulsed)
- Flat Leakage: < 18.5 dBm
- Spike Leakage < 20.5 dBm
- Passive (no DC bias required)
- Recovery time < 30 ns
- Package Dimensions: 4.00 x 4.00 x 1.640 mm

Performance is typical across frequency. Please reference electrical specification table and data plots for more details.

Applications

- Receive Chain Protection
- Commercial and Military Radar

Ordering Information

Part	Description
TGL2209–SM	8.0–12.0 GHz 50W VPIN Limiter 50 Piece 3x3 Waffle Pack
TGL2209-SMTR7	8.0–12.0 GHz 50W VPIN Limiter 750 Piece 7" Reel
TGL2209–SMEVBP01	8.0–12.0 GHz 50W VPIN Limiter Evaluation Board

Absolute Maximum Ratings

Parameter	Rating
Incident Power, Pulsed ¹ , 50 Ω, 25 °C	47 dBm
Incident Power, Pulsed ¹ , 50 Ω, 85 °C	46 dBm
Incident Power, CW, 50 Ω, 25 °C	40 dBm
Incident Power, CW, 50 Ω, 85 °C	36 dBm
Mounting Temperature (30 s max)	260 °C
Storage Temperature	-40 to 150 °C

Note:

¹ Pulse conditions: PW = 100 us, Duty Cycle = 10%

Exceeding any one or a combination of the Absolute Maximum Rating conditions may cause permanent damage to the device. Extended application of Absolute Maximum Rating conditions to the device may reduce device reliability.

Electrical Specifications

Parameter	Conditions ⁽¹⁾	Min	Typ.	Max	Units
Operational Frequency Range		8.0		12.0	GHz
Insertion Loss	8 GHz		0.35	0.75	dB
	9 GHz		0.35	0.75	
	10 GHz		0.35	0.90	
	11 GHz		0.36	1.00	
	12 GHz		0.40	1.00	
Input Return Loss	8 GHz		24		dB
	10 GHz		25		
	12 GHz		19		
Output Return Loss	8 GHz		24		dB
	10 GHz		29		
	12 GHz		20		
Flat Leakage Power at P _{IN} > 30 dBm (Pulse)	8 GHz		18.0		dBm
	10 GHz		17.5		
	12 GHz		18.5		
Pulse Recovery Time			<30		ns
Spike Leakage			20.5		dBm
Insertion Loss Temperature Coefficient			0.006		dB/ °C

Notes:

1. Test conditions unless otherwise noted: Temp = +25 °C, 50 Ω system.

Thermal and Reliability Information

Parameter	Test Conditions	Value	Units
Incident Power (RF Operational Life Test ⁽¹⁾)	10 GHz Pulsed, PW=100 us, DC=10%, 50 Ω, 25 °C	50	W

Notes:

1. Test was terminated after 100 hours.

Performance Plots – Small Signal

Test conditions unless otherwise noted: Temp.=+25 °C

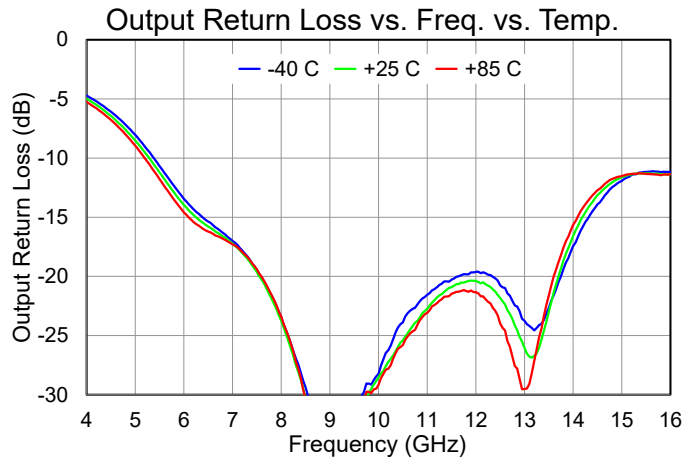
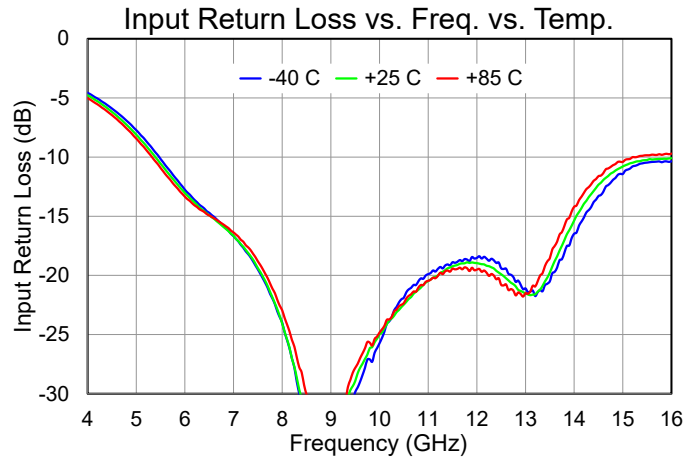
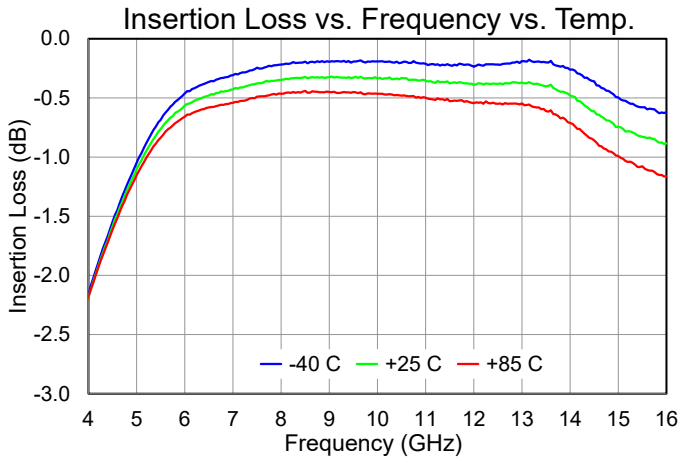

Performance Plots – Large Signal

Test conditions unless otherwise noted: CW power, Temp.=+25 °C

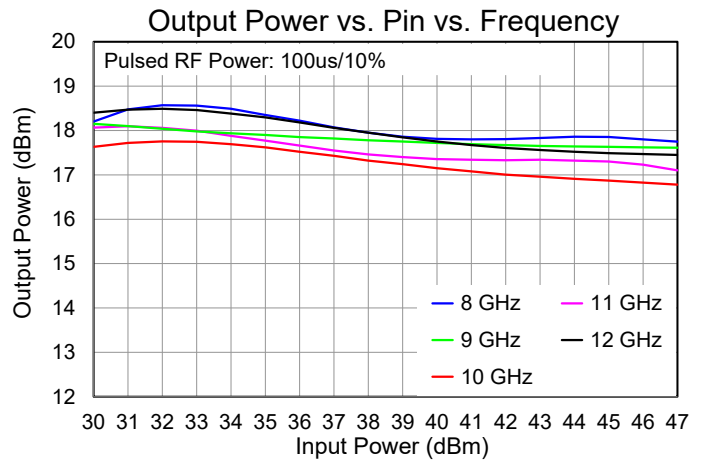
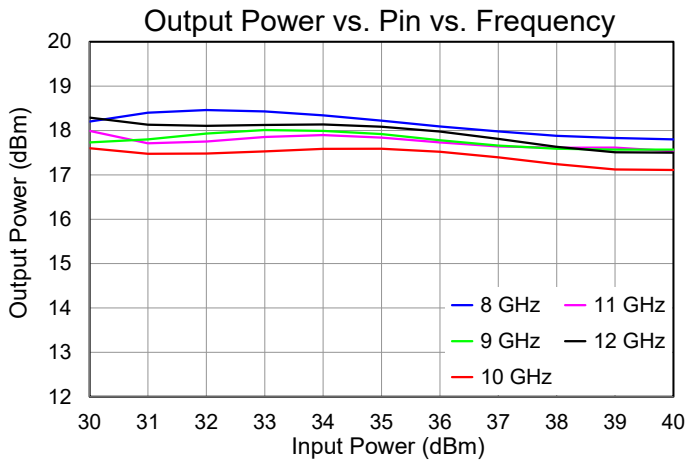
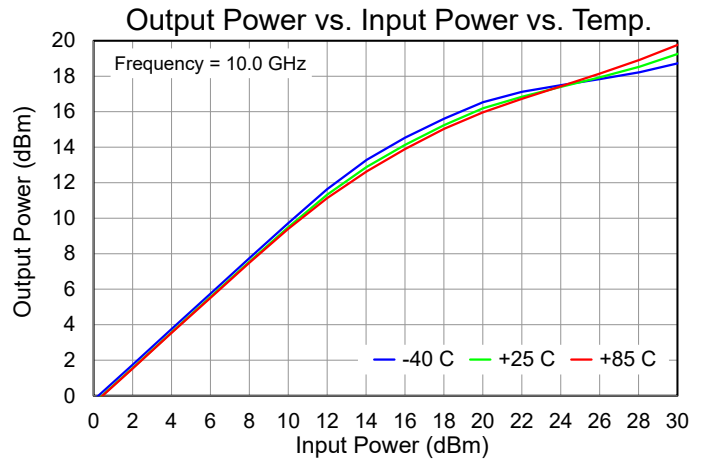
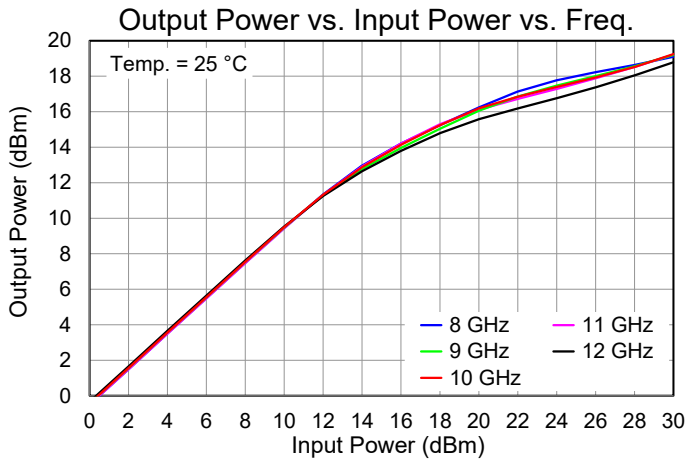

Application Circuit and Evaluation Board (EVB)

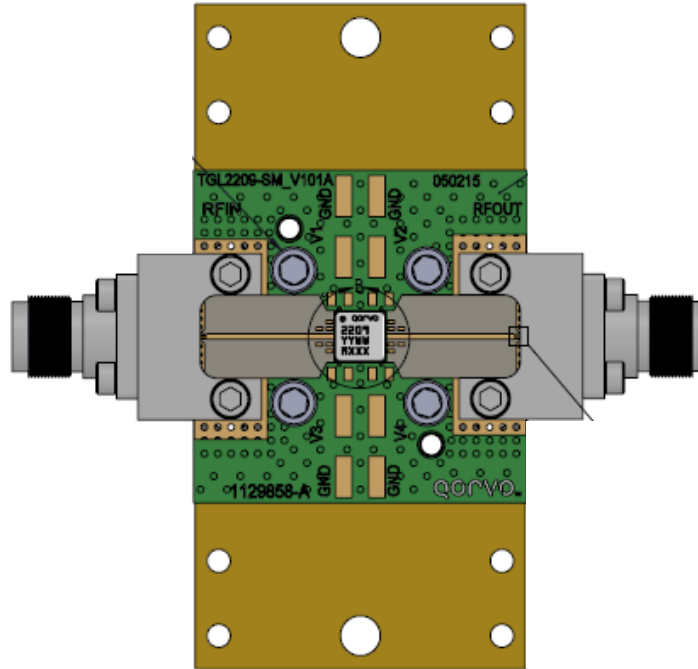

Notes:

1. See Evaluation Board PCB Information for material and stack up.

Bill of Material – EVB

Ref. Des.	Value	Description	Manuf.	Part Number
n/a	n/a	Printed Circuit Board	Qorvo	
U1	n/a	8 – 12 GHz 50 W VPIN Limiter	Qorvo	TGL2209–SM
J1, J2	n/a	2.92 mm End Launch Connector	Southwest Microwave	1092–01A–5

Evaluation Board PCB Information and Mounting Detail

EVB PC Board Layout

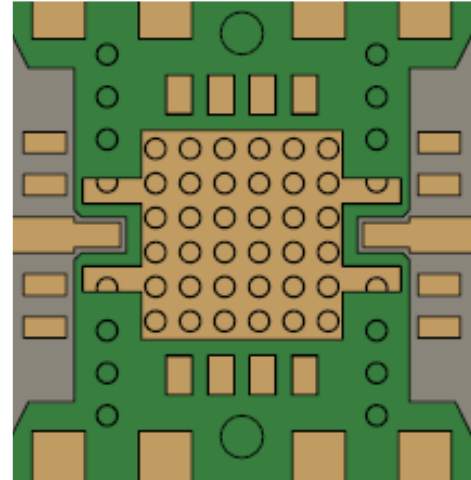
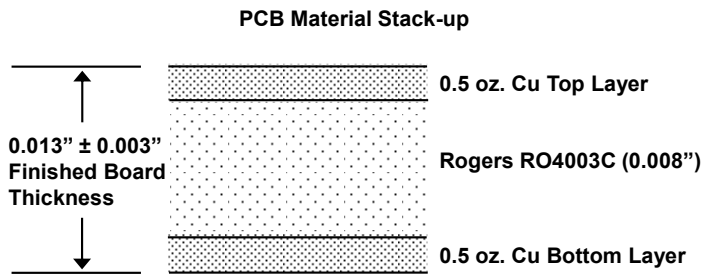

Pad Configuration and Description

- Pin 1 Indicator
- Qorvo Logo - Use Q5D
- Trace Code to be assigned by SubCon
- 2D Matrix

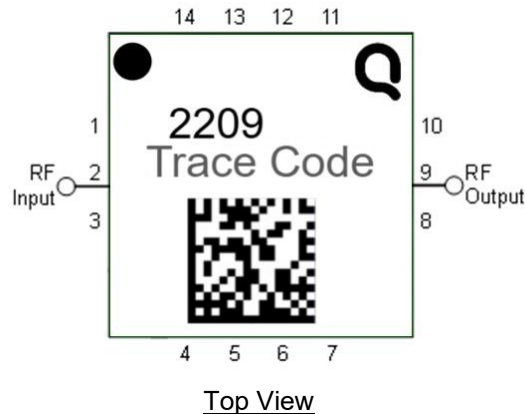

Pad No.	Label	Description
1, 3, 8, 10	GND	On PCB, multiple copper-filled vias should be employed under the center pad to minimize inductance and thermal resistance
2	RF Input	RF Input, matched to 50 Ohms, not DC blocked
4 – 7, 11 – 14	NC	No connection; may be grounded if desired
9	RF Output	RF Output, matched to 50 Ohms, not DC blocked

NOTE: The RF Input and RF Output ports are not interchangeable.

Mechanical Information

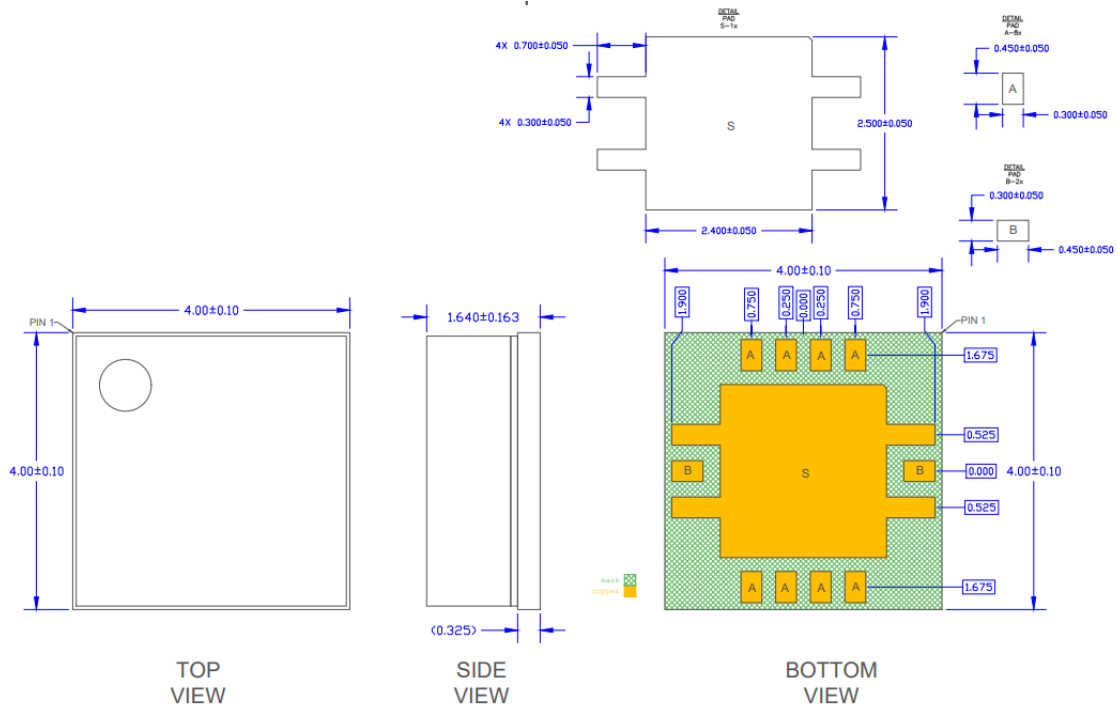

PCB Mounting Pattern

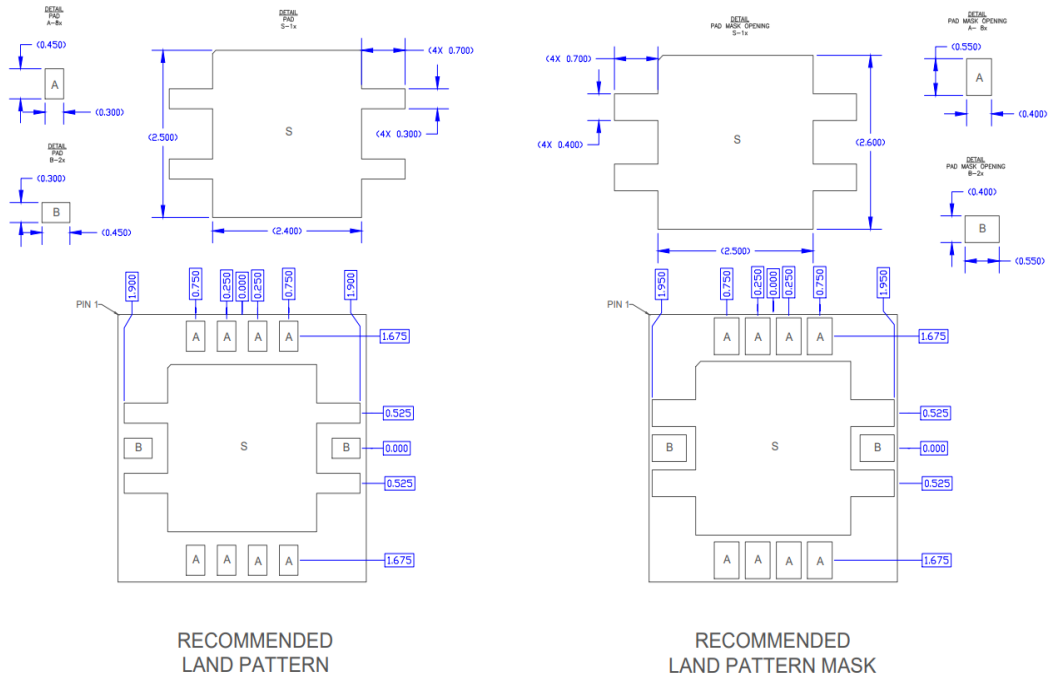

Notes:

1. All dimensions are in millimeters. Angles are in degrees.
2. This drawing specifies the mounting pattern used on the Qorvo evaluation board for this product. Some modification may be necessary to suit end user assembly materials and processes.

Tape and Reel Information – Carrier and Cover Tape Dimensions

Tape and reel specifications for this part are also available on the Qorvo website.
Standard T/R size = 750 pieces on a 7" reel.

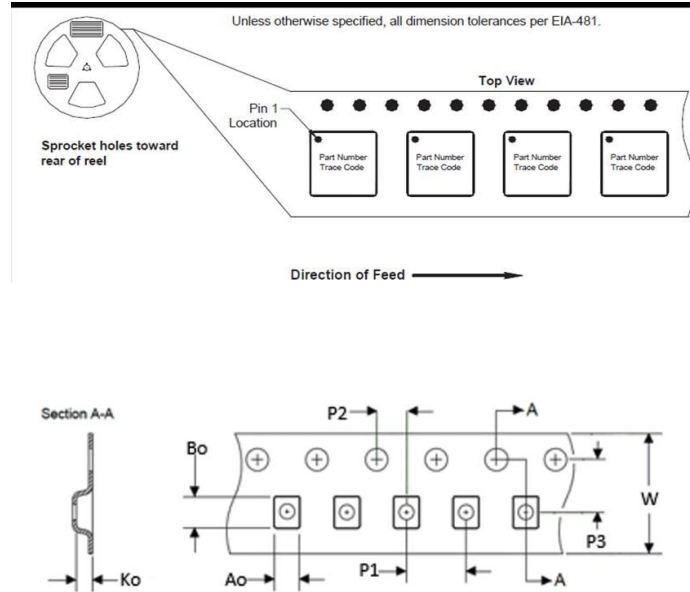

Feature	Measure	Symbol	Size (in)	Size (mm)
Cavity	Length	A0	0.169	4.3
	Width	B0	0.169	4.3
	Depth	K0	0.083	2.1
	Pitch	P1	0.315	8
Centerline Distance	Cavity to Perforation - Length Direction	P2	0.079	2.0
	Cavity to Perforation - Width Direction	P3	0.217	5.5
Cover Tape	Width	C	0.362	9.2
Carrier Tape	Width	W	0.472	12

Tape and Reel Information – Reel Dimensions

Packaging reels are used to prevent damage to devices during shipping and storage, loaded carrier tape is typically wound onto a plastic take-up reel. The reel size is 7" diameter. The reels are made from high-impact injection-molded polystyrene (HIPS), which offers mechanical and ESD protection to packaged devices.

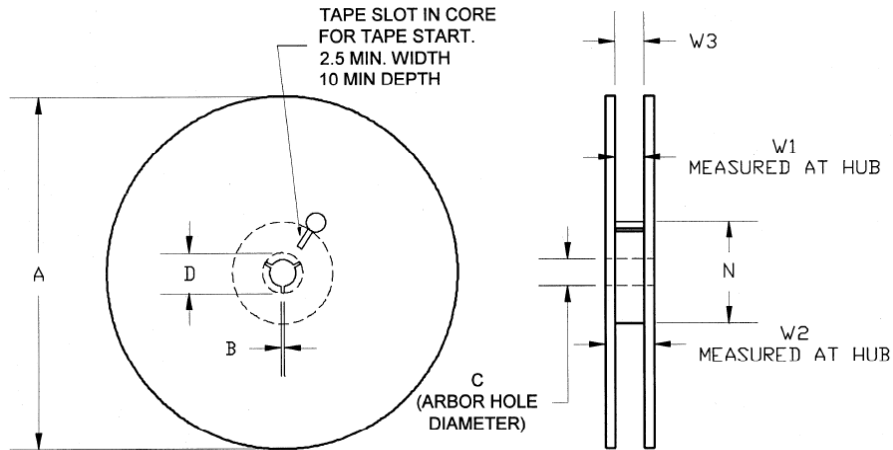

Feature	Measure	Symbol	Size (in)	Size (mm)
Flange	Diameter	A	6.969	177.0
	Thickness	W2	0.724	18.4
	Space Between Flange	W1	0.488	12.4
Hub	Outer Diameter	N	2.283	58.0
	Arbor Hole Diameter	C	0.512	13.0
	Key Slit Width	B	0.079	2.0
	Key Slit Diameter	D	0.795	20.2

Tape and Reel Information – Tape Length and Label Placement

Tape and reel specifications for this part are also available on the Qorvo website.

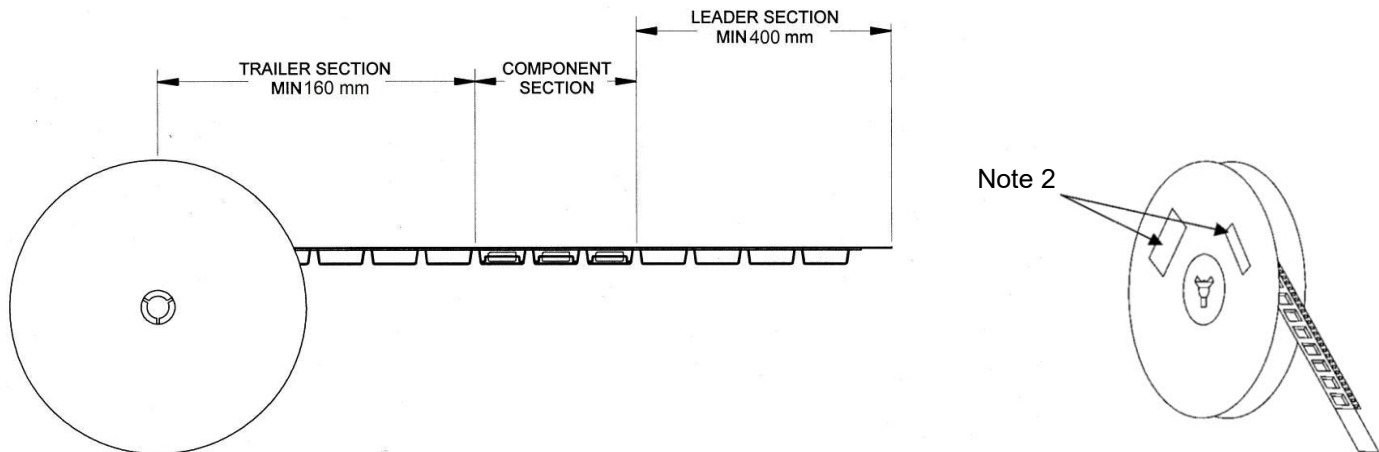

Notes:

1. Empty part cavities at the trailing and leading ends are sealed with cover tape. See EIA 481.
2. Labels are placed on the flange opposite the sprockets in the carrier tape.

Assembly Notes

- Compatible with lead-free soldering process with 260°C peak reflow temperature.
- This package is non-hermetic and therefore cannot be subjected to aqueous washing. The use of no-clean solder to avoid washing after soldering is recommended.
- Solder rework not recommended.
- Contact plating: Ni-Pd-Au

Recommended Soldering Profile

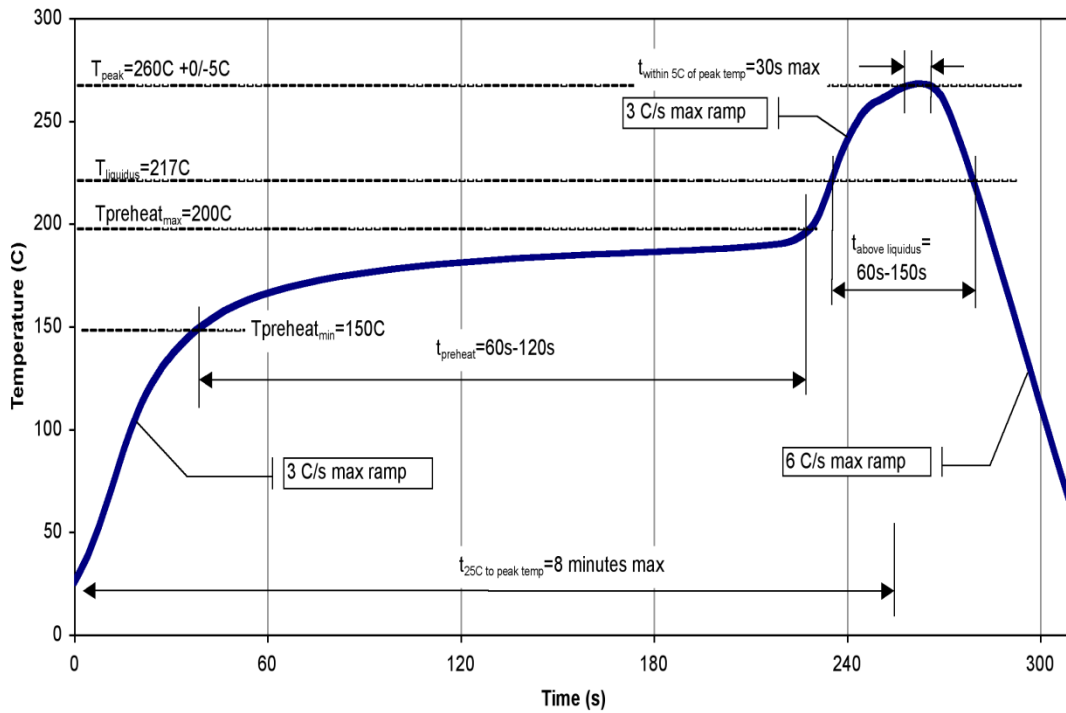

Handling Precautions

Parameter	Rating	Standard
ESD – Human Body Model (HBM)	Class 1C	ESDA / JEDEC JS-001-2012
ESD – Charged Device Model (CDM)	Class C3	JEDEC JESD22-C101F
MSL – Moisture Sensitivity Level	Level 3	IPC/JEDEC J-STD-020



Caution!
ESD-Sensitive Device

RoHS Compliance

This part is compliant with 2011/65/EU RoHS directive (Restrictions on the Use of Certain Hazardous Substances in Electrical and Electronic Equipment) as amended by Directive 2015/863/EU.

This product also has the following attributes:

- Lead Free
- Antimony Free
- TBBP-A (C₁₅H₁₂Br₄O₂) Free
- PFOS Free
- SVHC Free

Contact Information

For the latest specifications, additional product information, worldwide sales and distribution locations:

Web: www.qorvo.com

Tel: 1-844-890-8163

Email: customer.support@qorvo.com

Important Notice

The information contained herein is believed to be reliable; however, Qorvo makes no warranties regarding the information contained herein and assumes no responsibility or liability whatsoever for the use of the information contained herein. All information contained herein is subject to change without notice. Customers should obtain and verify the latest relevant information before placing orders for Qorvo products. The information contained herein or any use of such information does not grant, explicitly or implicitly, to any party any patent rights, licenses, or any other intellectual property rights, whether with regard to such information or anything described by such information. **THIS INFORMATION DOES NOT CONSTITUTE A WARRANTY WITH RESPECT TO THE PRODUCTS DESCRIBED HEREIN, AND QORVO HEREBY DISCLAIMS ANY AND ALL WARRANTIES WITH RESPECT TO SUCH PRODUCTS WHETHER EXPRESS OR IMPLIED BY LAW, COURSE OF DEALING, COURSE OF PERFORMANCE, USAGE OF TRADE OR OTHERWISE, INCLUDING THE IMPLIED WARRANTIES OF MERCHANTABILITY AND FITNESS FOR A PARTICULAR PURPOSE.**

Without limiting the generality of the foregoing, Qorvo products are not warranted or authorized for use as critical components in medical, lifesaving, or life-sustaining applications, or other applications where a failure would reasonably be expected to cause severe personal injury or death.

Copyright 2026 © Qorvo, Inc. | Qorvo is a registered trademark of Qorvo, Inc.