

Product Overview

The TQP3M9019 is a cascade-able, high linearity gain block amplifier in a low-cost surface-mount package. At 1.9 GHz, the amplifier typically provides 22 dB gain, +39.5 dBm OIP3, and 1.3 dB Noise Figure while only drawing 125 mA current. The device is housed in a leadfree / green / RoHS-compliant industry-standard 16-pin 3 x 3 mm QFN package.

The TQP3M9019 has the benefit of having high gain across a broad range of frequencies while also providing very low noise. This allows the device to be used in both receiver and transmitter chains for high performance systems. The amplifier is internally matched using a high-performance E-pHEMT process and only requires an external RF choke and blocking/bypass capacitors for operation from a single +5 V supply. The internal active bias circuit also enables stable operation over bias and temperature variations.

The TQP3M9019 covers the 0.02 – 4 GHz frequency band and is targeted for wireless infrastructure or other applications requiring high linearity and / or low noise figure.

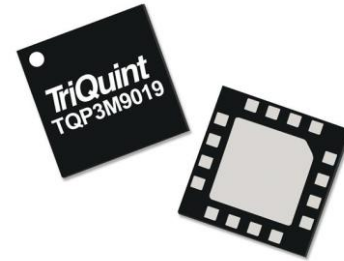

16 Pin 3X3 mm QFN Package

Key Features

- 20-4000 MHz
- 22 dB Gain at 1900 MHz
- 1.3 dB Noise Figure at 1900 MHz
- +39.5 dBm Output IP3
- 50 Ohm cascade-able Gain Block
- Unconditionally Stable
- High Input Power Capability
- +5 V Single Supply, 125mA Current
- 3x3 mm QFN Package

Functional Block Diagram

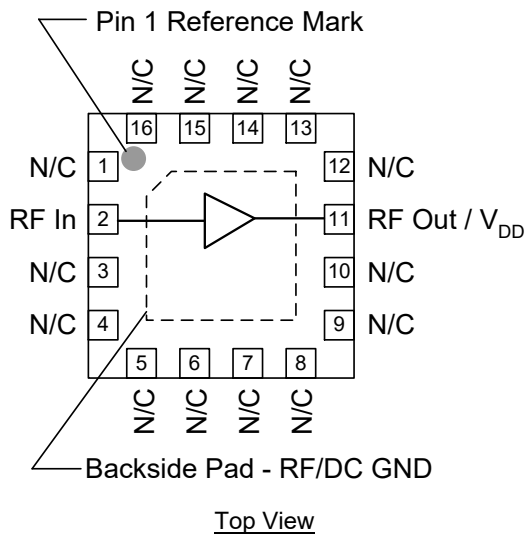

Applications

- Repeaters
- Mobile Infrastructure
- LTE / WCDMA / CDMA / EDGE
- General Purpose Wireless

Ordering Information

Part No.	Description
TQP3M9019	2500 pieces on a 7" reel
TQP3M9019-PCB_IF	50-500 MHz Evaluation Board
TQP3M9019-PCB_RF	0.5-4 GHz Evaluation Board

Absolute Maximum Ratings

Parameter	Rating
Storage Temperature	-65 to 150°C
RF Input Power, CW, 50Ω, T=25°C	+23 dBm
Supply Voltage (V _{DD})	+7 V
Reverse Supply Voltage	-0.3 V

Exceeding any one or a combination of the Absolute Maximum Rating conditions may cause permanent damage to the device.

Recommended Operating Conditions

Parameter	Min	Typ	Max	Units
Supply Voltage (V _{DD})	+4.75	+5.0	+5.25	V
T _{CASE}	-40		+105	°C
T _{ch} (for >10 ⁶ hours MTTF)			+190	°C

Electrical specifications are measured at specified test conditions. Specifications are not guaranteed over all recommended operating conditions. Application of conditions to the device outside the Recommended Operating Conditions may reduce device reliability and performance.

Electrical Specifications

Test conditions unless otherwise noted: V_{DD}=+5 V, Temp.=+25 °C, 50 Ω system

Parameter	Conditions	Min	Typ	Max	Units
Operational Frequency Range		20		4000	MHz
Test Frequency			1900		MHz
Gain		20	22	23	dB
Input Return Loss			10		dB
Output Return Loss			13		dB
Output P1dB			+22		dBm
Output IP3	P _{out} =+3 dBm/tone, Δf = 1 MHz	+36	+39.5		dBm
Noise Figure			1.3		dB
Current, I _{DD}			125	150	mA
Thermal Resistance, θ _{jc}	Module (junction to case)			34	°C/W

Evaluation Board – TQP3M9019-PCB_RF

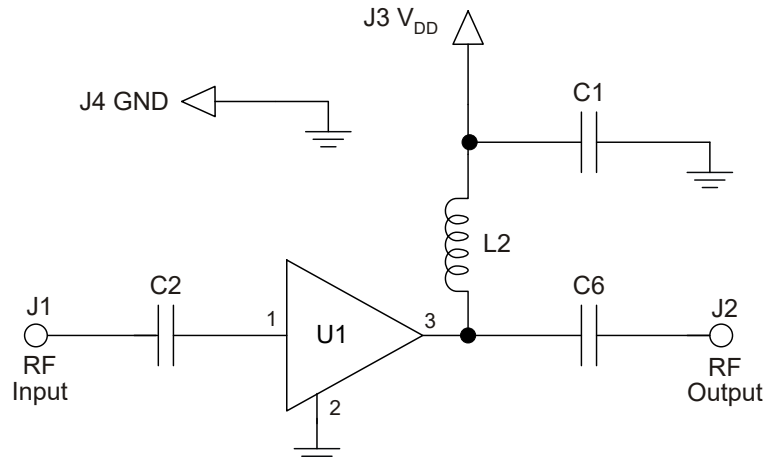
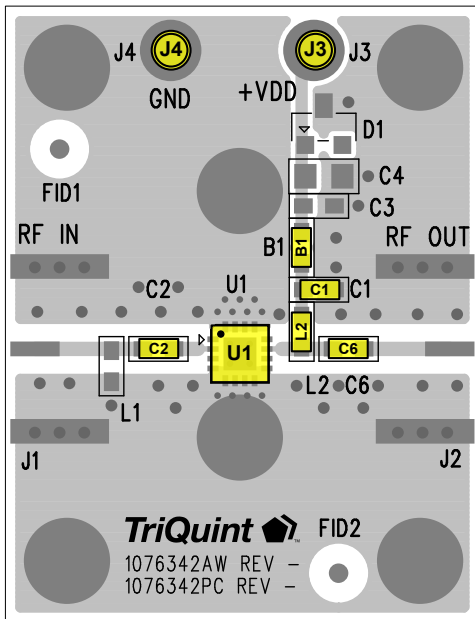

Notes:

1. See Evaluation Board PCB Information section for material and stack-up.
2. Components shown on the silkscreen but not on the schematic are not used.
3. B1 (0 Ω jumper) is not shown on the schematic and may be replaced with copper trace in the target application layout.
4. The recommended component values are dependent upon the frequency of operation.
5. All components are of 0603 size unless otherwise specified.

Bill of Material – TQP3M9019-PCB_RF

Reference Des.	Value	Description	Manuf.	Part Number
n/a	n/a	Printed Circuit Board	Qorvo	
U1	n/a	High Linearity LNA Gain Block	Qorvo	TQP3M9019
C2, C6	100 pF	CAP, 0603, 5%, 100V, NPO/COG	various	
C1	0.01 uF	CAP, 0603, 5%, 50V, X7R	various	
L2	68 nH	IND, 0603, 5%	CoilCraft	0603CS-68NXJL
B1	0 Ω	RES, 0603	various	
L1, D1, C3, C4	DNP	n/a	n/a	n/a

Notes:

1. Performances can be optimized at frequency of interest by using recommended component values shown in the table below. Inductors are wirewound Coilcraft

Reference Des.	Frequency (MHz)					
	50	200	500	2000	2500	3500
C2, C6	0.01 uF	1000 pF	100 pF	22 pF	22 pF	22 pF
L2	470 nH	220 nH	82 nH	22 nH	18 nH	15 nH

Typical Performance – TQP3M9019-PCB_RF

Test conditions unless otherwise noted: $V_{DD} = +5\text{ V}$, $I_{DD} = 125\text{ mA (typ.)}$, Temp = $+25^\circ\text{C}$

Parameter	Typical Value						Units
Frequency	500	900	1900	2700	3500	4000	MHz
Gain	25.6	24.6	22	20.5	19	18.3	dB
Input Return Loss	11	10.5	10	11.5	8	6	dB
Output Return Loss	10.5	12	13	9	10	11	dB
Output P1dB	+22.4	+22.3	+22	+21.7	+21.4	+20.8	dBm
OIP3 (1)	+41.8	+40.6	+40.6	+38.5	+38.8	+37.9	dBm
Noise figure (2)	0.9	0.9	1.3	1.7	2.1	2.4	dB

Notes:

- OIP3 measured with two tones at an output power of +3 dBm / tone separated by 1 MHz.
- Noise figure data listed in the table above includes PCB losses. $\sim 0.1\text{ dB @ } 2\text{ GHz}$.

Performance Plots – TQP3M9019-PCB_RF

Test conditions unless otherwise noted: $V_{DD} = +5\text{ V}$, $I_{DD} = 125\text{ mA typ.}$, Temp = $+25^\circ\text{C}$

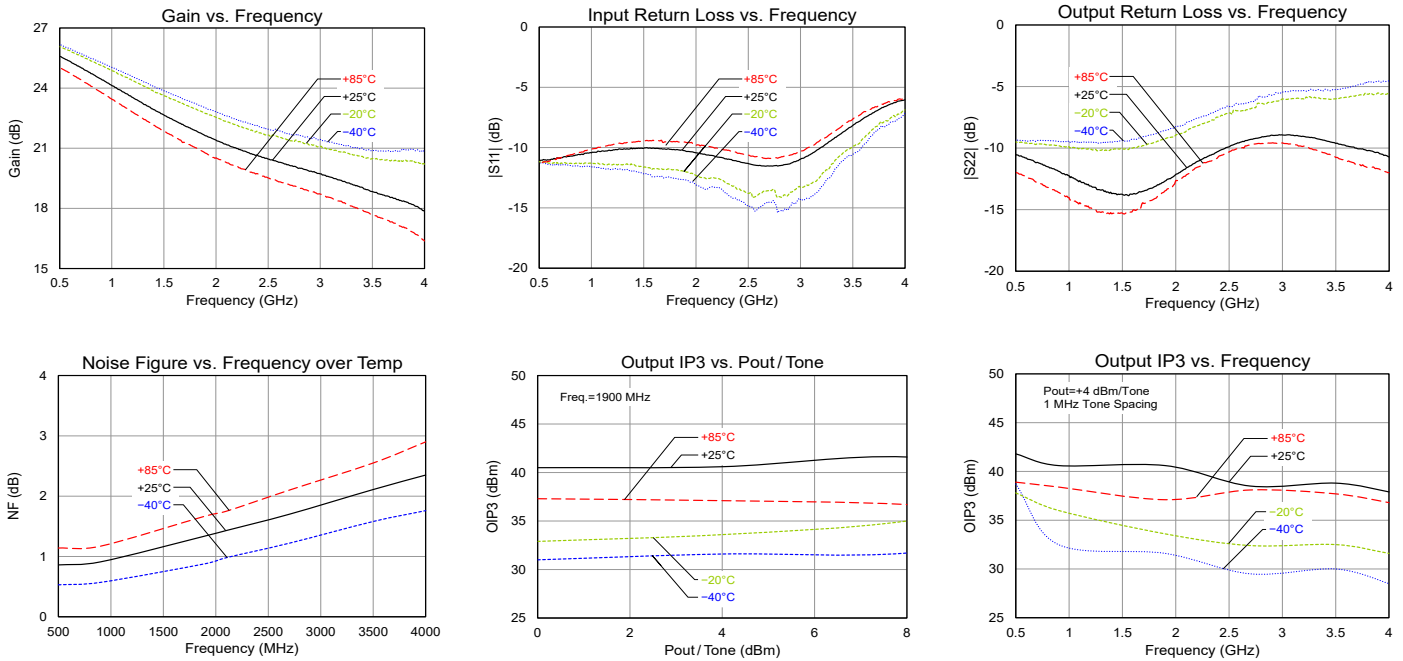

Performance Plots – TQP3M9019-PCB_RF

Test conditions unless otherwise noted: $V_{DD}=+5V$, $I_{DD}=125\text{ mA typ.}$, Temp= $+25^{\circ}\text{C}$.

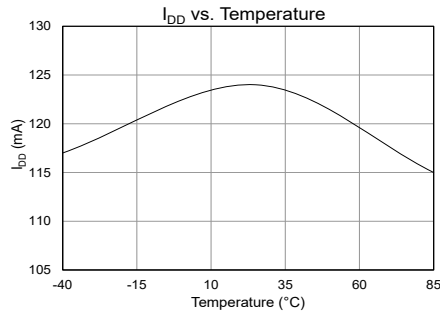
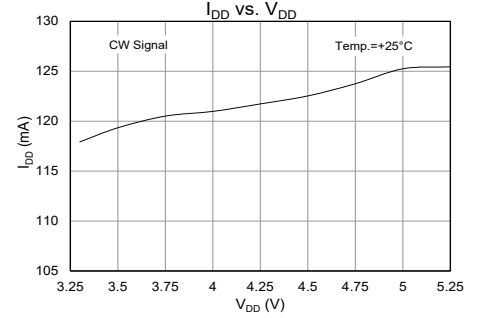
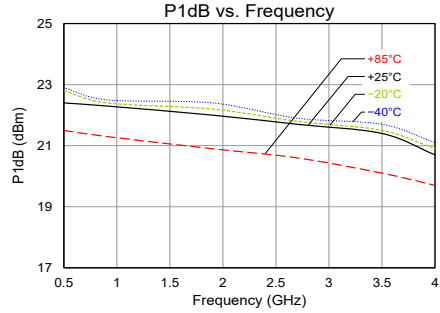
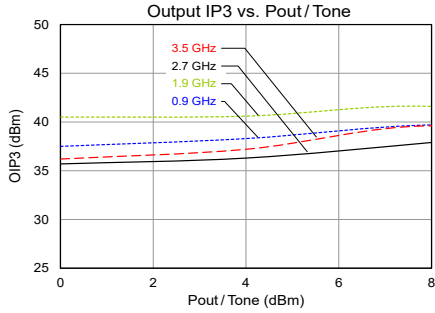

Evaluation Board – TQP3M9019-PCB_IF

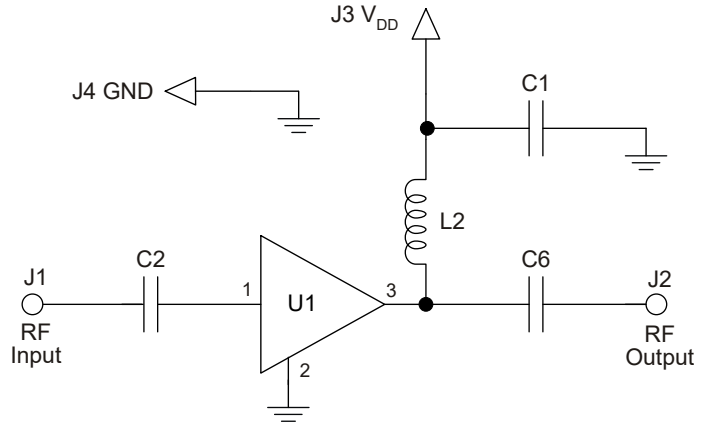
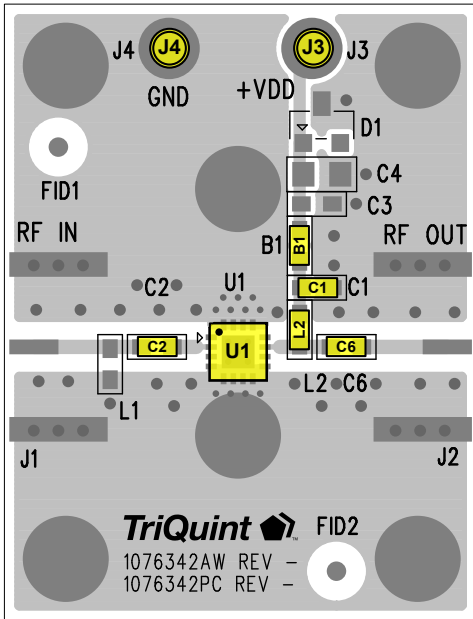

Notes:

1. See Evaluation Board PCB Information section for material and stack-up.
2. Components shown on the silkscreen but not on the schematic are not used.
3. B1 (0 Ω jumper) is not shown on the schematic and may be replaced with copper trace in the target application layout.
4. The recommended component values are dependent upon the frequency of operation.
5. All components are of 0603 size unless stated on the schematic.

Bill of Material – TQP3M9019-PCB_IF

Reference Des.	Value	Description	Manuf.	Part Number
n/a	n/a	Printed Circuit Board	Qorvo	
U1	n/a	High Linearity LNA Gain Block	Qorvo	TQP3M9019
C2, C6	1000 pF	CAP, 0603, 5%, 50V, X7R	various	
C1	0.01 μ F	CAP, 0603, 5%, 50V, X7R	various	
L2	330 nH	IND, 0603, 5%	CoilCraft	0603CS-R33XJL
B1	0 Ω	RES, 0603	various	
L1, D1, C3, C4	DNP	n/a	n/a	n/a

Notes:

1. Performances can be optimized at frequency of interest by using recommended component values shown in the table below. Inductors are wirewound Coilcraft

Reference Des.	Frequency (MHz)					
	50	200	500	2000	2500	3500
C2, C6	0.01 μ F	1000 pF	100 pF	22 pF	22 pF	22 pF
L2	470 nH	220 nH	82 nH	22 nH	18 nH	15 nH

Typical Performance – TQP3M9019-PCB_IF

Test conditions unless otherwise noted: $V_{DD} = +5\text{ V}$, $I_{DD} = 125\text{ mA (typ.)}$, Temp = $+25^\circ\text{C}$

Parameter	Typical Value				Units
Frequency	70	100	200	500	MHz
Gain	27	26.8	26.4	25.8	dB
Input Return Loss	12	13	13	13	dB
Output Return Loss	11	11	12	13	dB
Output P1dB	+21.6	+21.9	+21.9	+22.2	dBm
OIP3	+37.6	+38.8	+39	+41.4	dBm
Noise figure	1.4	1.3	0.9	0.9	dB

Notes:

1. OIP3 measured with two tones at an output power of +3 dBm / tone separated by 1 MHz.
2. Noise figure data listed in the table above includes PCB losses. $\sim 0.1\text{ dB @ } 2\text{ GHz}$.

Performance Plots – TQP3M9019-PCB_IF

Test conditions unless otherwise noted: $V_{DD} = +5\text{ V}$, $I_{DD} = 125\text{ mA typ.}$, Temp = $+25^\circ\text{C}$

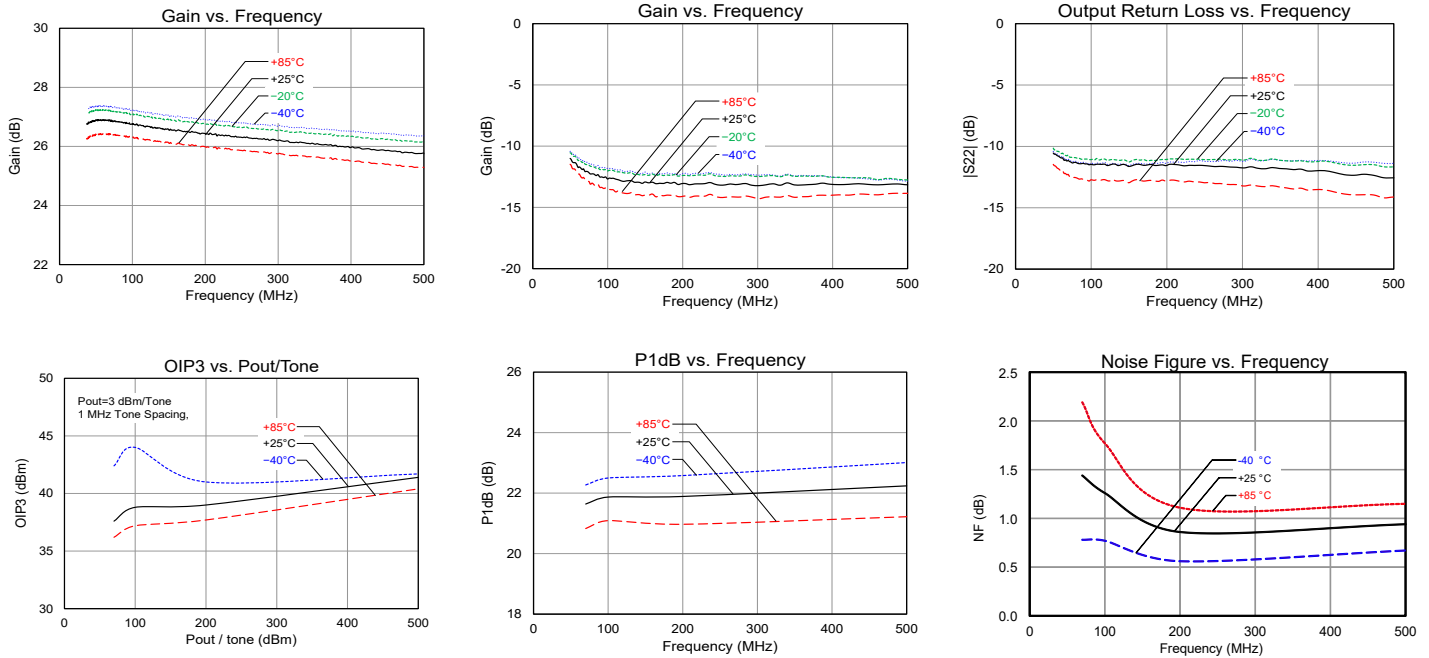

Pad Configuration and Description

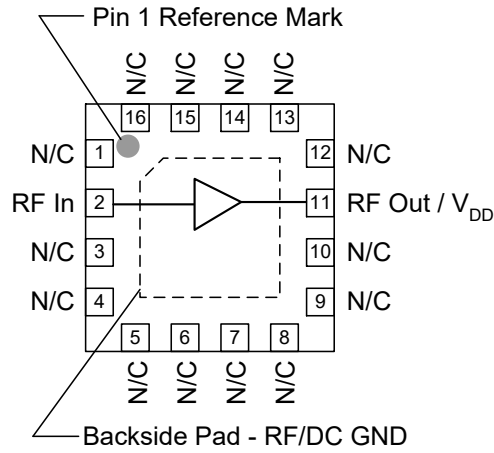

Top View

Pad No.	Label	Description
2	RF In	RF input matched to 50 ohms. External DC Block is required.
11	RF Out / V _{DD}	RF output matched to 50 ohms. Bias voltage and external DC Block required.
All other pins	N/C	No internal connection. Provide grounded PCB land pads for optimal isolation and mounting integrity.
Backside Pad	RF/DC GND	RF/DC ground. Use recommended via pattern to minimize inductance and thermal resistance. See PCB Mounting Pattern.

Evaluation Board PCB Information

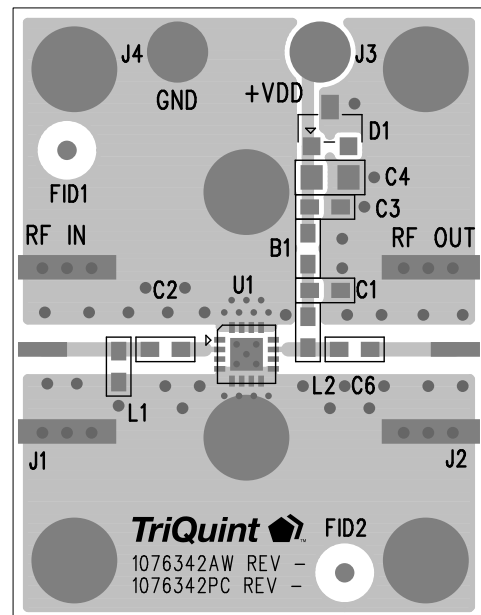
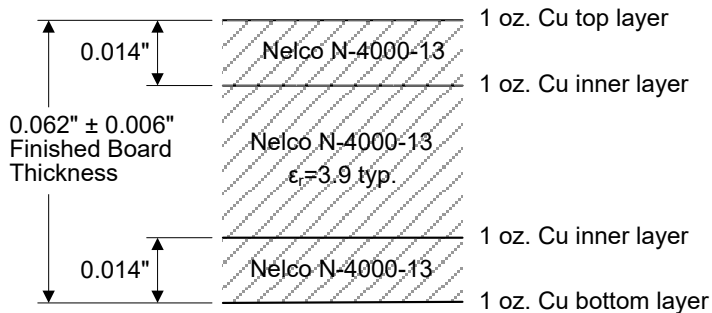

Package Marking and Dimensions

Package Marking: Part number – 9019
Year/week/country code – YYWW
Lot code – aXXXX

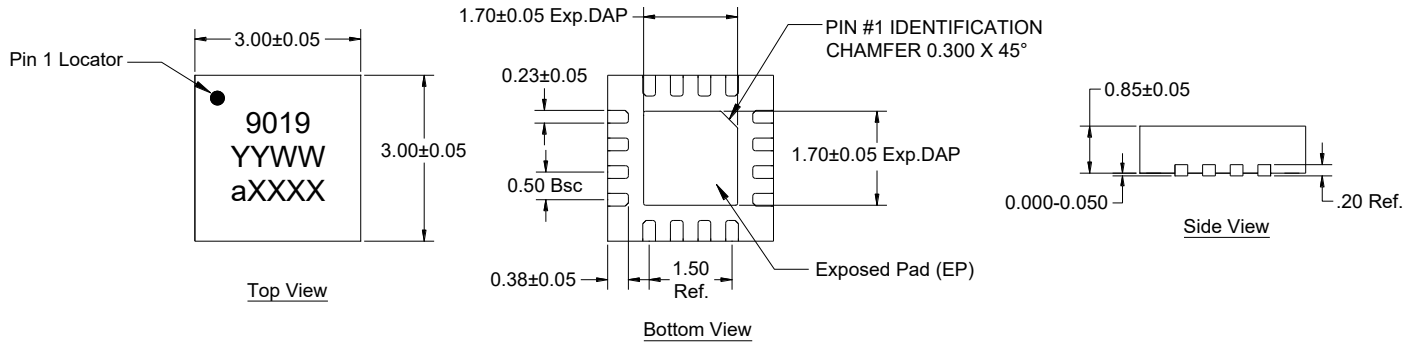

Notes:

1. All dimensions are in millimeters. Angles are in degrees.
2. Dimension and tolerance formats conform to ASME Y14.4M-1994.
3. The terminal #1 identifier and terminal numbering conform to JESD 95-1 SPP-012.

Recommended PCB Layout Pattern

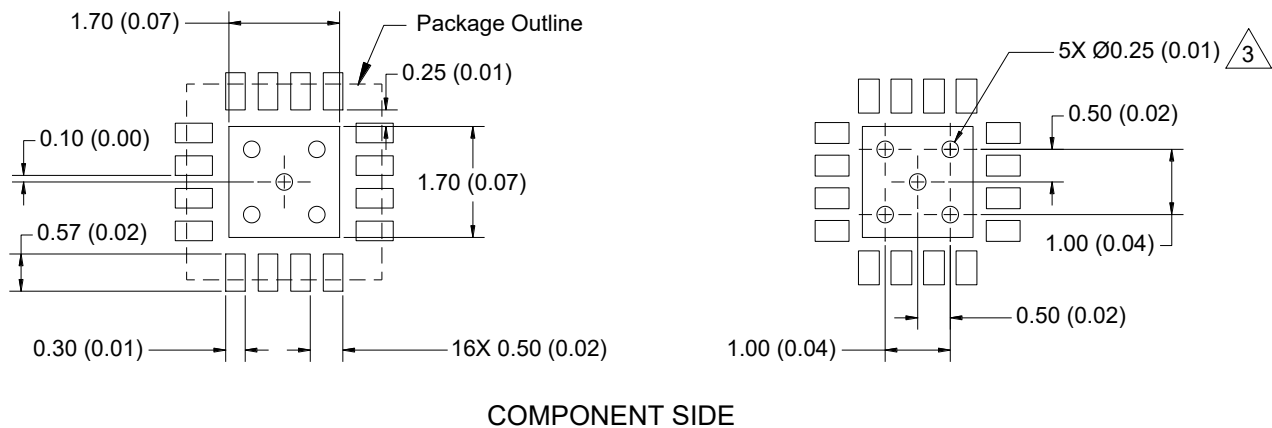

Notes:

1. All dimensions are in millimeters (inches). Angles are in degrees.
2. Use 1 oz. copper minimum for top and bottom layer metal.
3. Ground/thermal vias are required for the proper operation of this device. We recommend a 0.35 mm (#80/.0135") diameter bit for drilling via holes and a final plated thru diameter of 0.25 mm (0.10").
4. Ensure good package backside exposed pad (EP) solder attach for best electrical and thermal performance.

Tape and Reel Information – Carrier and Cover Tape Dimensions

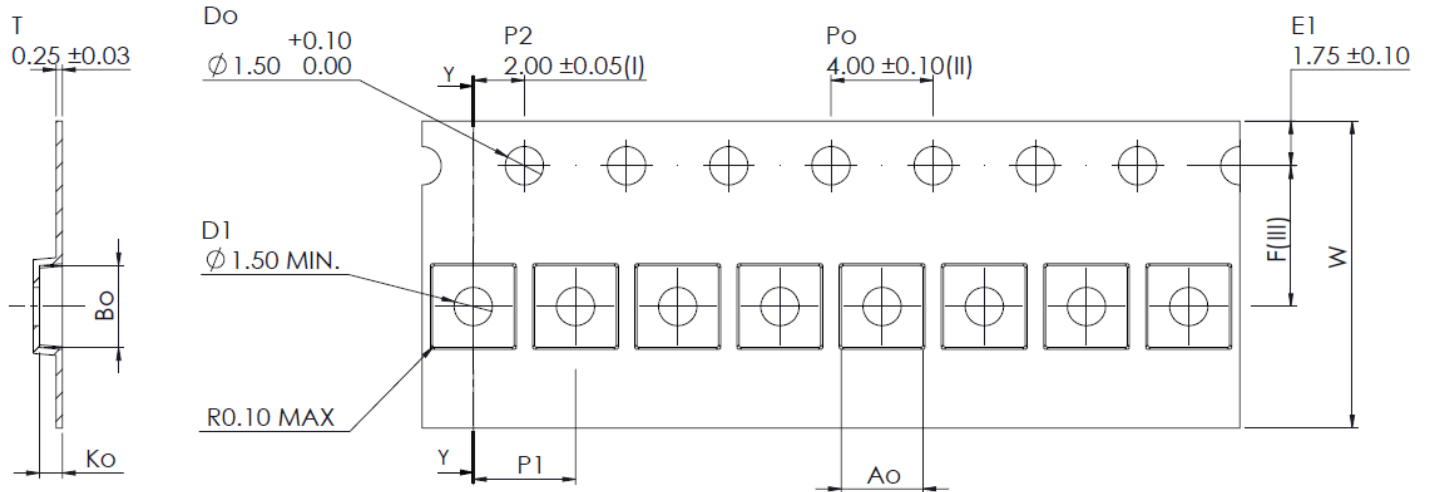

Feature	Measure	Symbol	Size (in)	Size (mm)
Cavity	Length	A0	0.125	3.20
	Width	B0	0.125	3.20
	Depth	K0	0.039	1.00
	Pitch	P1	0.157	4.00
Centerline Distance	Cavity to Perforation - Length Direction	P2	0.079	2.00
	Cavity to Perforation - Width Direction	F	0.217	5.50
Carrier Tape	Width	W	0.472	12.0

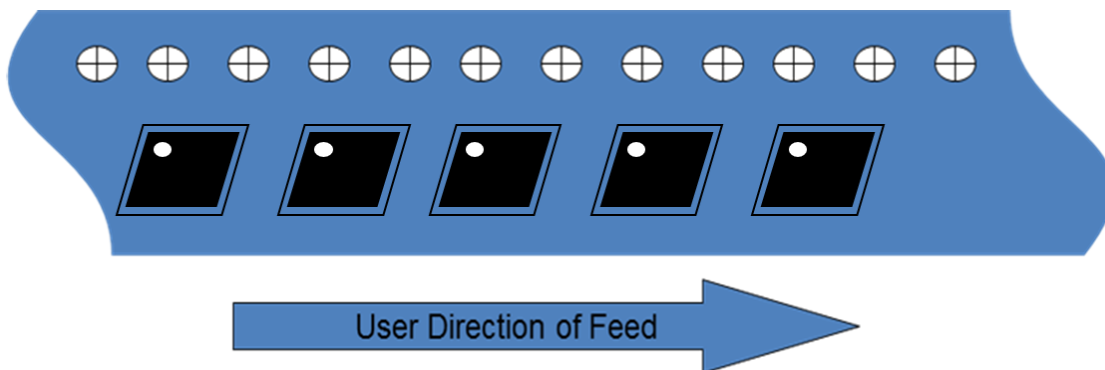

Tape and Reel Information – Reel Dimensions

Standard T/R size = 2,500 pieces on a 7" reel.

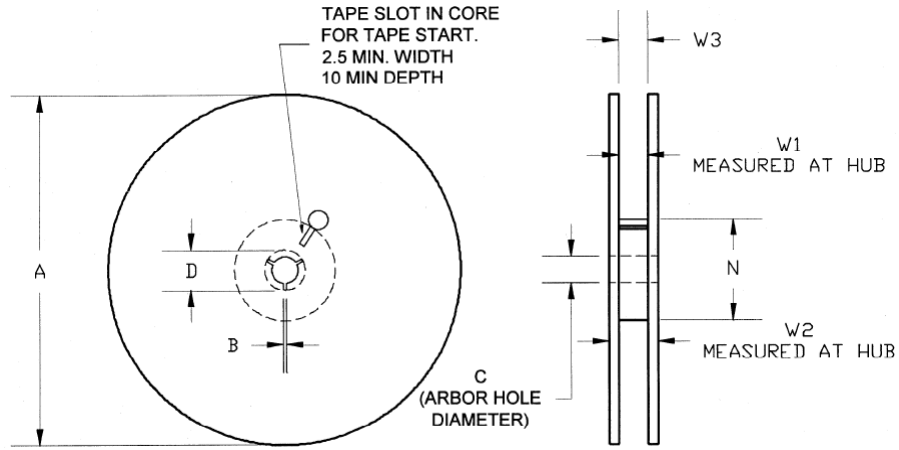

Feature	Measure	Symbol	Size (in)	Size (mm)
Flange	Diameter	A	6.969	177.00
	Thickness	W2	0.717	18.20
	Space Between Flange	W1	0.504	12.80
Hub	Outer Diameter	N	2.283	58.00
	Arbor Hole Diameter	C	0.512	13.00
	Key Slit Width	B	0.079	2.00
	Key Slit Diameter	D	0.787	20.00

Tape and Reel Information – Tape Length and Label Placement

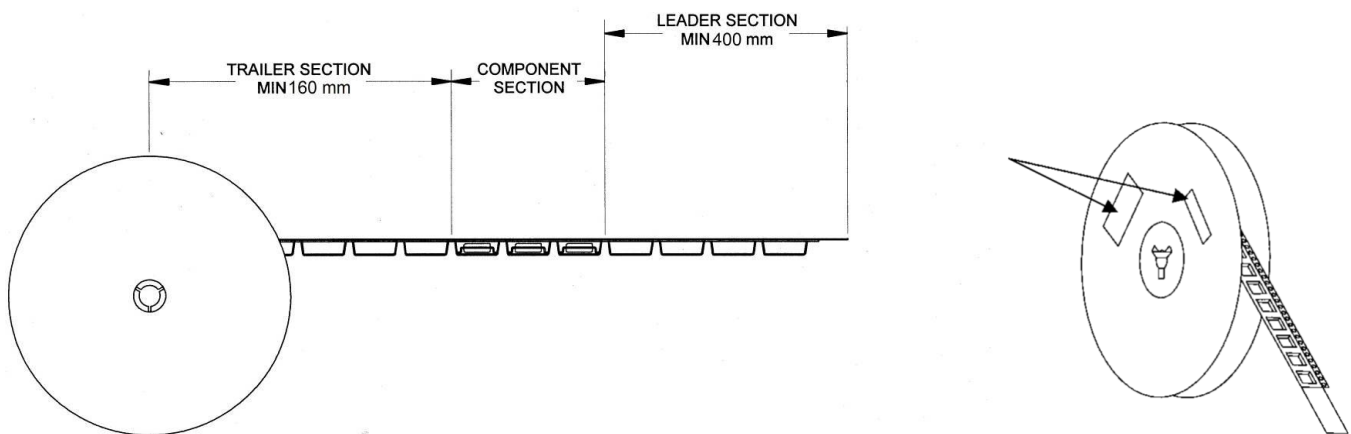

- Notes:
1. Empty part cavities at the trailing and leading ends are sealed with cover tape. See EIA 481-1-A.
 2. Labels are placed on the flange opposite the sprockets in the carrier tape.

Handling Precautions

Parameter	Rating	Standard
ESD – Human Body Model (HBM)	1A	ESDA / JEDEC JS-001-2017
ESD – Charged Device Model (CDM)	C3	JEDEC JESD22-C101F
MSL – Moisture Sensitivity Level	Level 1	IPC/JEDEC J-STD-020E



Caution!
ESD-Sensitive Device

Solderability

Compatible with both lead-free (260°C max. reflow temperature) and tin/lead (245°C max. reflow temperature) soldering processes. Solder profiles available upon request.

Contact plating: Annealed Matte Tin

RoHS Compliance

This part is compliant with 2011/65/EU RoHS directive (Restrictions on the Use of Certain Hazardous Substances in Electrical and Electronic Equipment) as amended by Directive 2015/863/EU.

This product also has the following attributes:

- Lead Free
- Halogen Free (Chlorine, Bromine)
- Antimony Free
- TBBP-A (C₁₅H₁₂Br₄O₂) Free
- PFOS Free
- SVHC Free



Contact Information

For the latest specifications, additional product information, worldwide sales and distribution locations:

Web: www.qorvo.com

Tel: 1-844-890-8163

Email: customer.support@qorvo.com

Important Notice

The information contained herein is believed to be reliable; however, Qorvo makes no warranties regarding the information contained herein and assumes no responsibility or liability whatsoever for the use of the information contained herein. All information contained herein is subject to change without notice. Customers should obtain and verify the latest relevant information before placing orders for Qorvo products. The information contained herein or any use of such information does not grant, explicitly or implicitly, to any party any patent rights, licenses, or any other intellectual property rights, whether with regard to such information itself or anything described by such information. **THIS INFORMATION DOES NOT CONSTITUTE A WARRANTY WITH RESPECT TO THE PRODUCTS DESCRIBED HEREIN, AND QORVO HEREBY DISCLAIMS ANY AND ALL WARRANTIES WITH RESPECT TO SUCH PRODUCTS WHETHER EXPRESS OR IMPLIED BY LAW, COURSE OF DEALING, COURSE OF PERFORMANCE, USAGE OF TRADE OR OTHERWISE, INCLUDING THE IMPLIED WARRANTIES OF MERCHANTABILITY AND FITNESS FOR A PARTICULAR PURPOSE.**

Without limiting the generality of the foregoing, Qorvo products are not warranted or authorized for use as critical components in medical, life-saving, or life-sustaining applications, or other applications where a failure would reasonably be expected to cause severe personal injury or death.

Copyright 2026 © Qorvo, Inc. | Qorvo is a registered trademark of Qorvo, Inc.