

Product Description

An excellent alternative to traveling wave tube amplifiers, Qorvo’s Spatium™ QPB1111 is a solid state, spatial-combining amplifier with an operating range of 34-36 GHz while achieving a minimum of 54 dBm (250 Watts) of instantaneous saturated power. With its maximum performance in gain, efficiency, signal flatness, and RF output power, this Spatium is the ideal building block for millimeter-wave sub-systems with wide-ranging applications.

Qorvo’s patented and field-proven Spatium combining technology provides unprecedented Solid-State Power Amplifier (SSPA) performance in a rugged, compact size and weight which reduces total cost of ownership compared to alternative technologies. This product offering combines Qorvo’s market leadership in GaN technology and Ka-band MMIC design along with our high-count combining techniques for a best in class solution to power amplification.

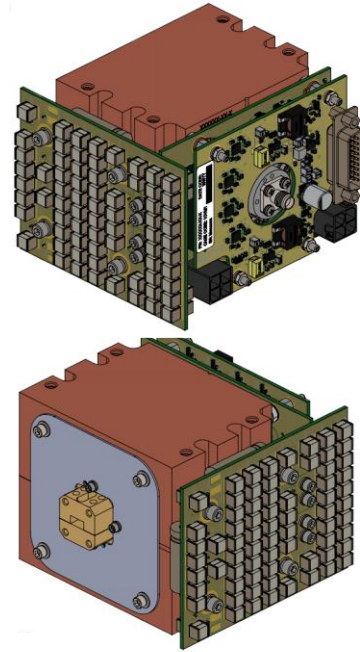

Functional Block Diagram

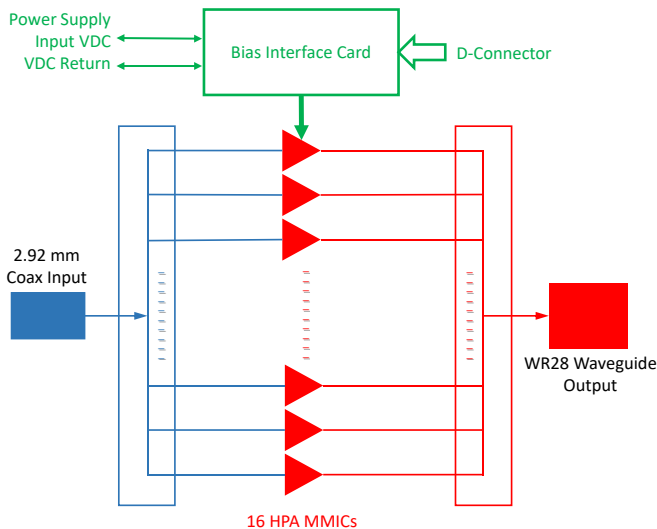

Product Features

- Frequency Range: 34 – 36 GHz
- Saturated Power: 55.4 dBm
- Efficiency: 16 %
- Solid State MMIC Reliability
- Multi-Element Redundancy
- Instant On (no warm up)

Performance is typical across frequency. Please reference electrical specification table and data plots for more details.

Applications

- TWTA Replacement

Part No.	Description
QPB1111	34 – 36 GHz GaN SSPA

Absolute Maximum Ratings

Parameter	Value / Range	Value / Range	Units
Max. DC Supply Voltage (V_{DC})	-	29.5	V
Min. DC Supply Voltage (V_{DC})	-	23.0	V
Drain Current (I_{D_DRIVE})	-	90	A
Max. RF Input Power (1.5:1 VSWR)	-	43	dBm
Operating Temperature*	-40	75	°C
Storage Temperature	-40	85	°C

Operation of this device outside the parameter ranges given above may cause permanent damage. These are stress ratings only, and functional operation of the device at these conditions is not implied.

* Refers to max/min temperature as measured on the two clamp surfaces utilized for heat rejection. The two clamp surfaces should handle equal amount of heat. Page 11 showed locations of the two surfaces.

Recommended Operating Conditions

Parameter	Min	Typ.	Max	Value / Range
Drain Voltage (V_D)		28		V
Quiescent Drain Current (I_{DQ})		5.4		A
Operating Drain Current (I_D)		38		A

Electrical specifications are measured at specified test conditions. Specifications are not guaranteed over all recommended operating conditions.

Electrical Specifications

Parameter	Min	Typ	Max	Units
Frequency	34		36	GHz
Output Power (Pulsed, $P_{IN} = 39$ dBm)		55.2		dBm
Power Gain (Pulsed, $P_{IN} = 39$ dBm)		16.2		dB
Gain Flatness vs Freq. (Pulsed, $P_{IN} = 39$ dBm)		0.6		dB
Efficiency (Pulsed, $P_{IN} = 39$ dBm)		16.0		%
Pulse Droop (PW=50 us, F=35 GHz, P_{IN} =39 dBm) @ -40C / + 25C / 55C / 75C.		0.7 / 0.8 / 1.0 / 1.6		dB
Rise Time (PW=20 ns, F=35 GHz, P_{IN} =39 dBm) @ -40C / + 25C / 55C / 75C, RF source pulsing		5.0 / 5.8 / 6.4 / 9.3		ns
Fall Time (PW=20 ns, F=35 GHz, P_{IN} =39 dBm) @ -40C / + 25C / 55C / 75C, RF source pulsing		2.9 / 3.1 / 3.1 / 3.4		ns
Fall Time (PW=200 us, F=35 GHz, P_{IN} =39 dBm) DC ENABLE pulsing		150	200	ns
Input Return Loss (CW)		13		dB
DC Power (average)		1100		W
Input RF Interface	2.92 mm (F) Coaxial Connector			
Output RF Interface	WR-28 Waveguide			
Weight: Amplifier + Bias Card		6.1 (2.77)		lbs. (kg)
Dimensions: Amplifier + Bias Card L x W x H		3.94 (100) x 2.91 (74) x 3.85 (98)		inch (mm)

Test conditions unless otherwise noted: $V_{DC} = 28$ V, $I_{DQ} = 5.4$ A, PW = 5 us, DC = 50%, 25 °C ambient

Typical Performance – Large Signal

Conditions unless otherwise specified: $V_D = +28\text{ V}$, $I_{DQ} = 5.4\text{ A}$, $P_{IN} = 39\text{ dBm}$, $T = 25\text{ }^\circ\text{C}$.
 Pulse Width = 5 μs , Duty Cycle = 50%, data shown are peak values.

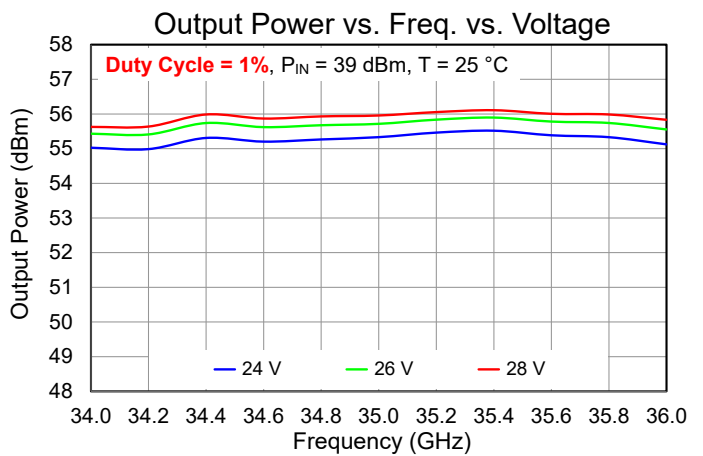
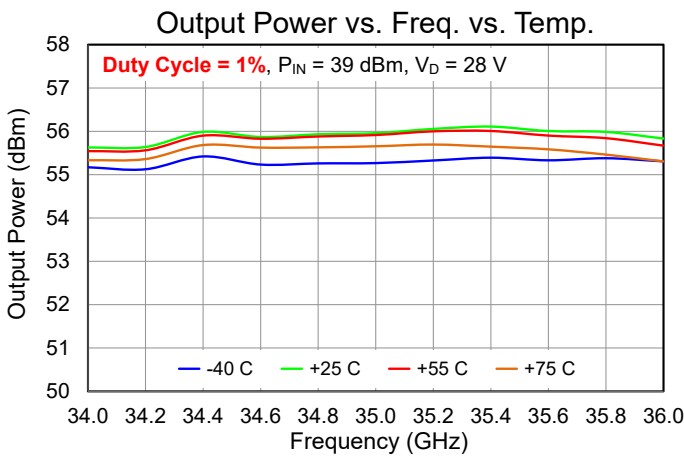
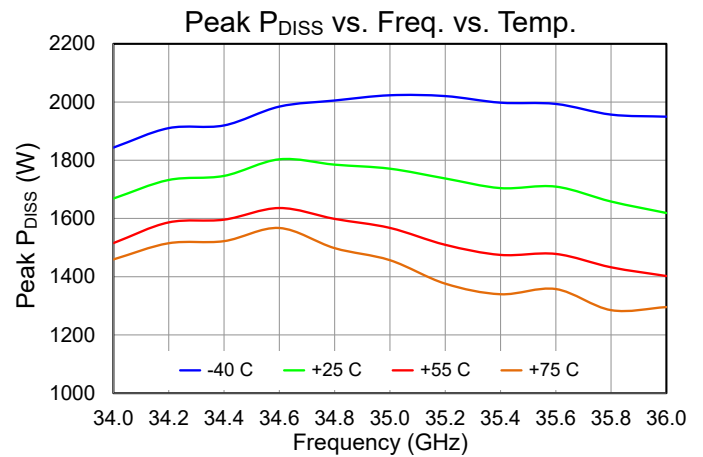
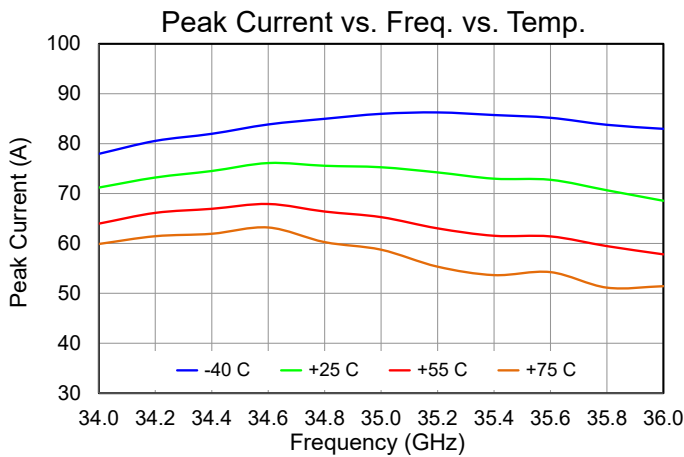
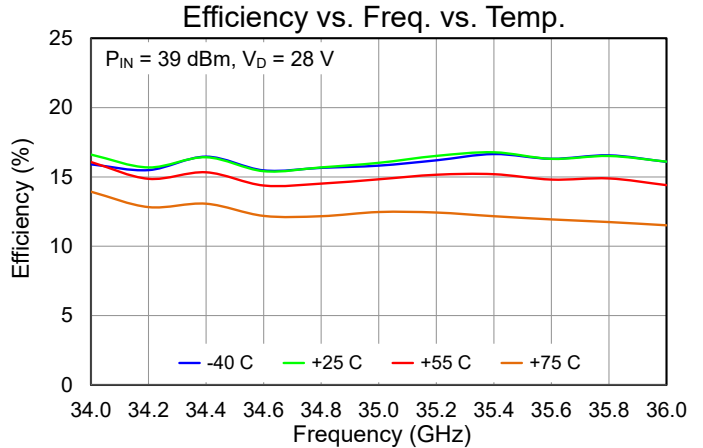
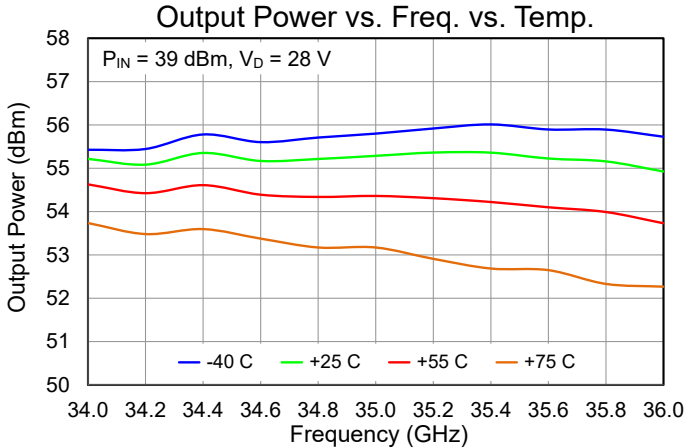

Typical Performance – Large Signal

Conditions unless otherwise specified: $V_D = +28\text{ V}$, $I_{DQ} = 5.4\text{ A}$, $P_{IN} = 39\text{ dBm}$, $T = 25\text{ }^\circ\text{C}$.
 Pulse Width = 5 us, Duty Cycle = 50%, data shown are peak values.

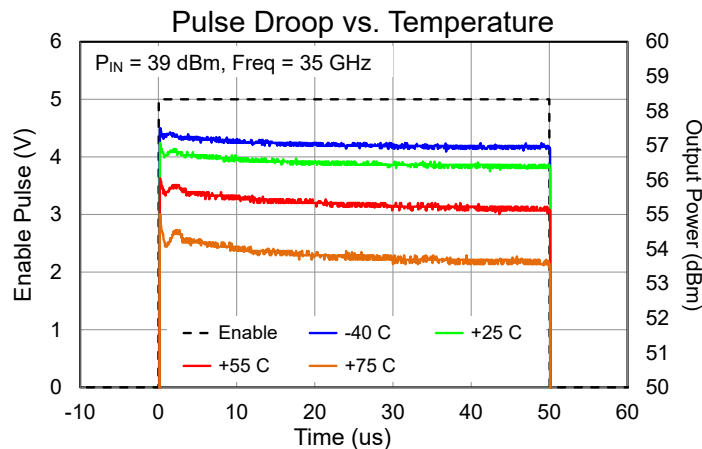
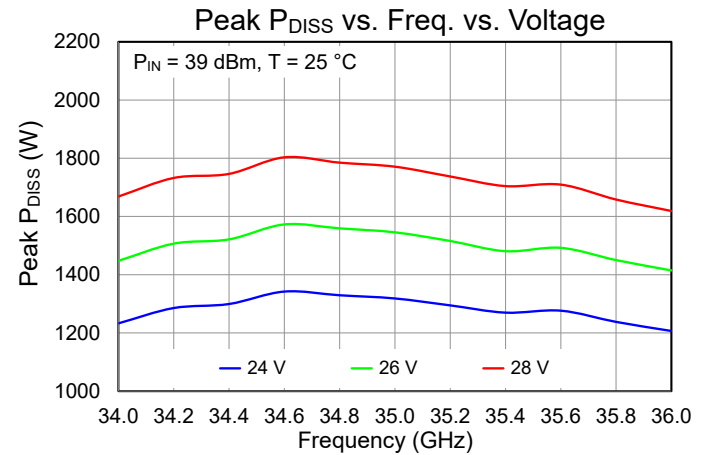
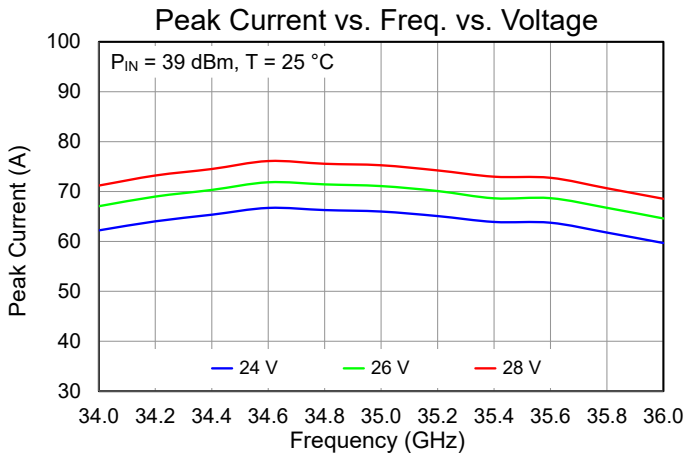
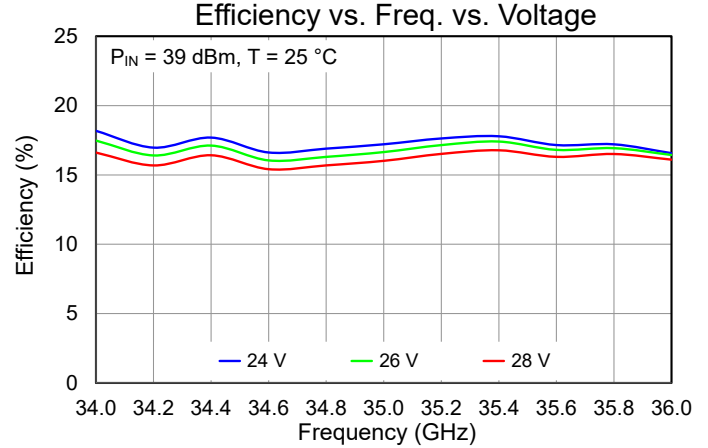
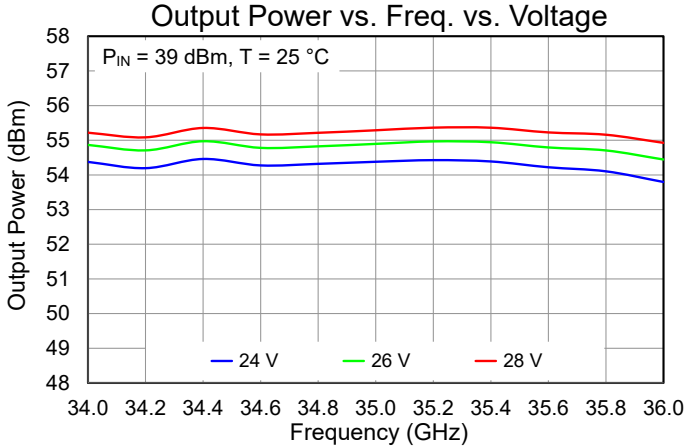

Typical Performance – Large Signal

Conditions unless otherwise specified: $V_D = +28\text{ V}$, $I_{DQ} = 5.4\text{ A}$, $T = 25\text{ }^\circ\text{C}$.
 Pulse Width = 5us, Duty Cycle = 50%, data shown are peak values.

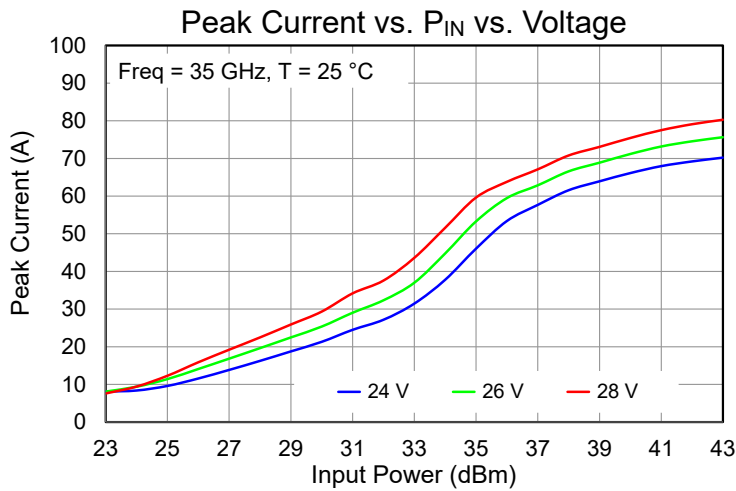
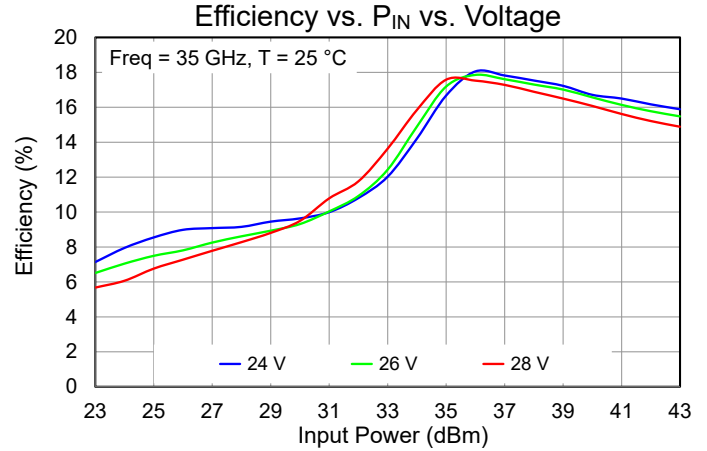
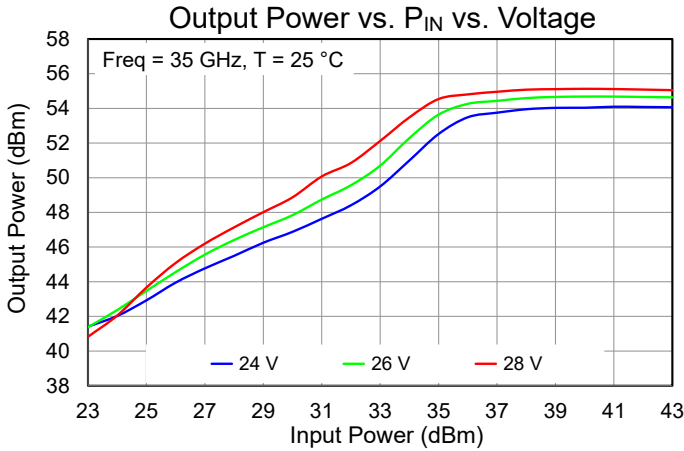

Typical Performance – Small Signal

Conditions unless otherwise specified: $V_D = +28\text{ V}$, $I_{DQ} = 5.4\text{ A}$, $T = 25\text{ }^\circ\text{C}$, CW.

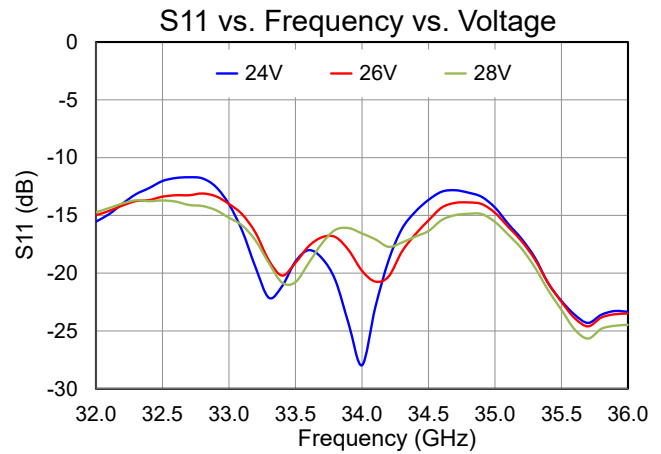
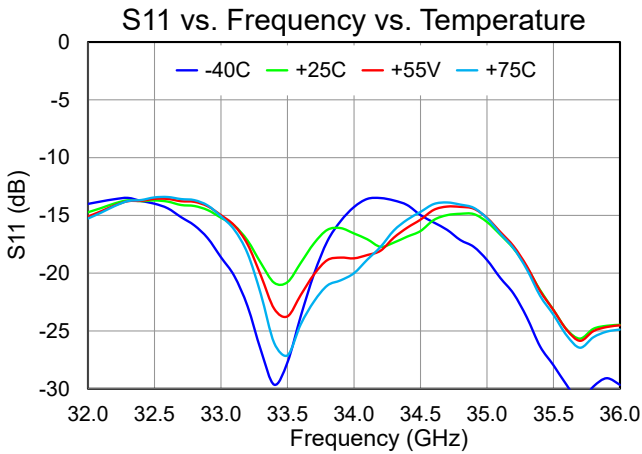
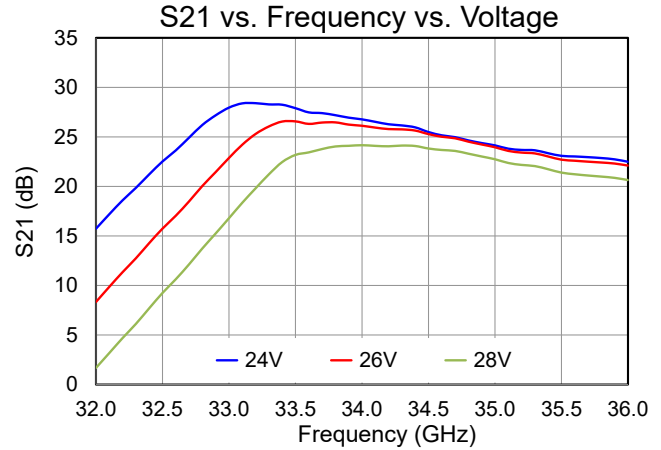
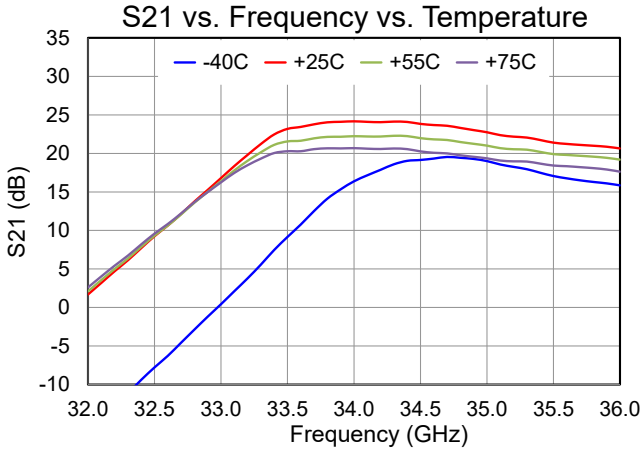



Reliability Information

QPB1111 MTBF (x1000 Hours), 50% Duty Cycle			
CLAMP TEMP (°C)	25	55	75
ENVIRONMENT	MTBF (x1000 Hours)		
AUC	72.4	23.1	9.2
GF	208.9	61.1	23.4
GB	722.3	164.8	54.7
QPB1111 FPMH (Failure Rate Per Million Hours), 50% Duty Cycle			
CLAMP TEMP (°C)	25	55	71
ENVIRONMENT	FPMH		
AUC	13.8	43.3	108.2
GF	4.8	16.4	42.7
GB	1.4	6.1	18.3

Calculations derived from MIL-HDBK-217F

Operational environments are:

GB – Ground Benign

GF – Ground Fixed

AUC – Airborne Uninhabited Cargo

Block Diagram and Description

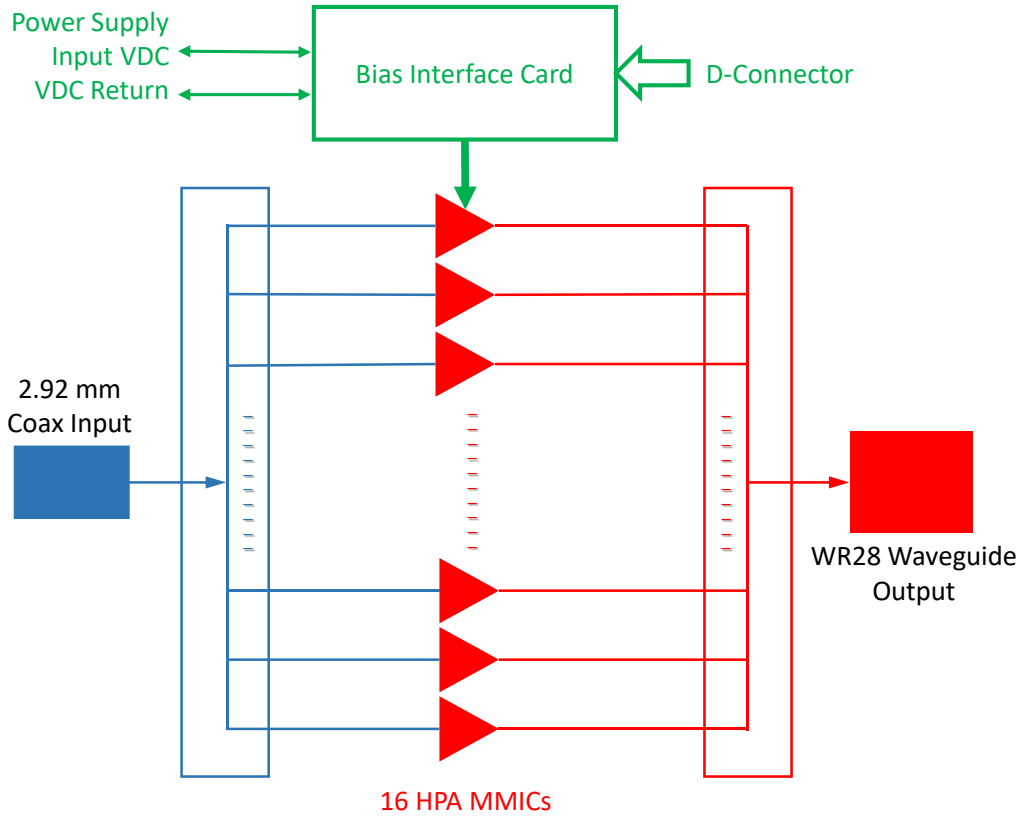

Pin No.	Label	Description
RF In	J10	2.92mm (F) Coaxial RF Input.
RF Out	J11	WR28 UG599/U Waveguide High Power RF Output
Auxiliary	J1	D-SUB HD 26POS (M), NorComp, 180-M26-113R9
Power	J3, J4	MOLEX, 07682900

Mechanical Information – Outline Drawing

NOTES: UNLESS OTHERWISE SPECIFIED

△ LABEL LOCATION.

SN: * * * * *
 BATCH I.D.
 WORK WEEK
 CALENDAR YEAR
 MANUFACTURER

PN: 200000J00X DATE CODE: WWYY
 CAGE CODE: 104M
 98 Measure

△ SPATIUM REQUIRES 2 SIDED COOLING ON OPPOSITE FACES INDICATED.

△ PRIMARY AND ALTERNATE MOUNTING OPTIONS FOR COOLING OR ATTACHMENT ARE LISTED ON INDICATED FACE.

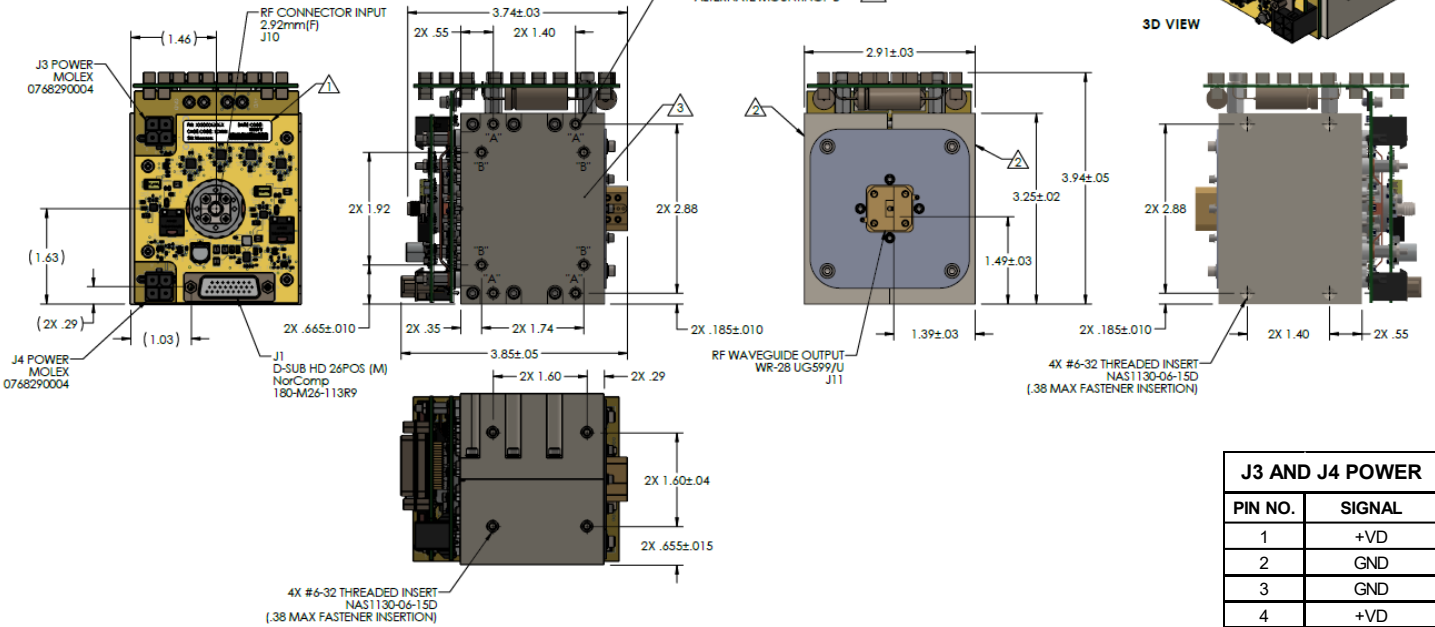
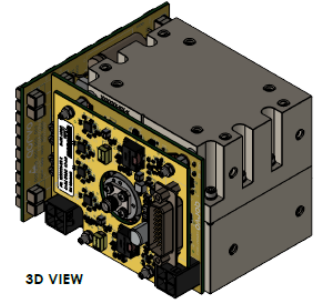
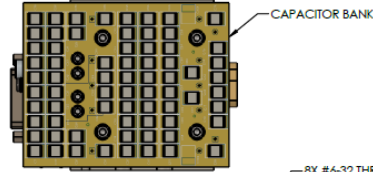

J3 AND J4 POWER	
PIN NO.	SIGNAL
1	+VD
2	GND
3	GND
4	+VD

J1 Connector Pin Labels and Function Descriptions

Pin No.	Label	Description
1 – 16	IDS_1 – IDS_16	Amplifier bias monitoring, voltage output on these pins follows 0.5V/A times the current flowing through amplifiers 1 to 16 of the Spatium. Can be used for diagnosis, otherwise leave open
17 - 18	5V0	+5V internally generated reference voltage, can be used to supply 100mA of current if required, otherwise, leave open. Do not apply voltage to these pins.
19 - 20	GND	Logic ground.
21	VTEMP	Temperature monitoring ¹ .
22	ENABLE	5V CMOS logic command bit for setting the gain stages to lo power mode operation. 0V puts the unit into a low-power stage while 5V will allow normal operation, in the absence of an external logic signal (open), the amplifier will power on with the application of supply voltage.
23	SCL	I2C bus used to program amplifier (for factory use only).
24	SDA	I2C bus used to program amplifier (for factory use only).
25	RESET	I2C bus used to program amplifier (for factory use only).
26	GND	Logic ground

- Pin connects to Texas Instruments KMT87 temperature sensor output.
 The temperature sensor is inside Spatium, not clamp surface.
 For relation between output voltage and temperature, please see the LMT87 datasheet.
<https://www.ti.com/lit/ds/symlink/lmt87.pdf>

Mechanical Information – Location Drawing for Heat Sinks / Cold Plates

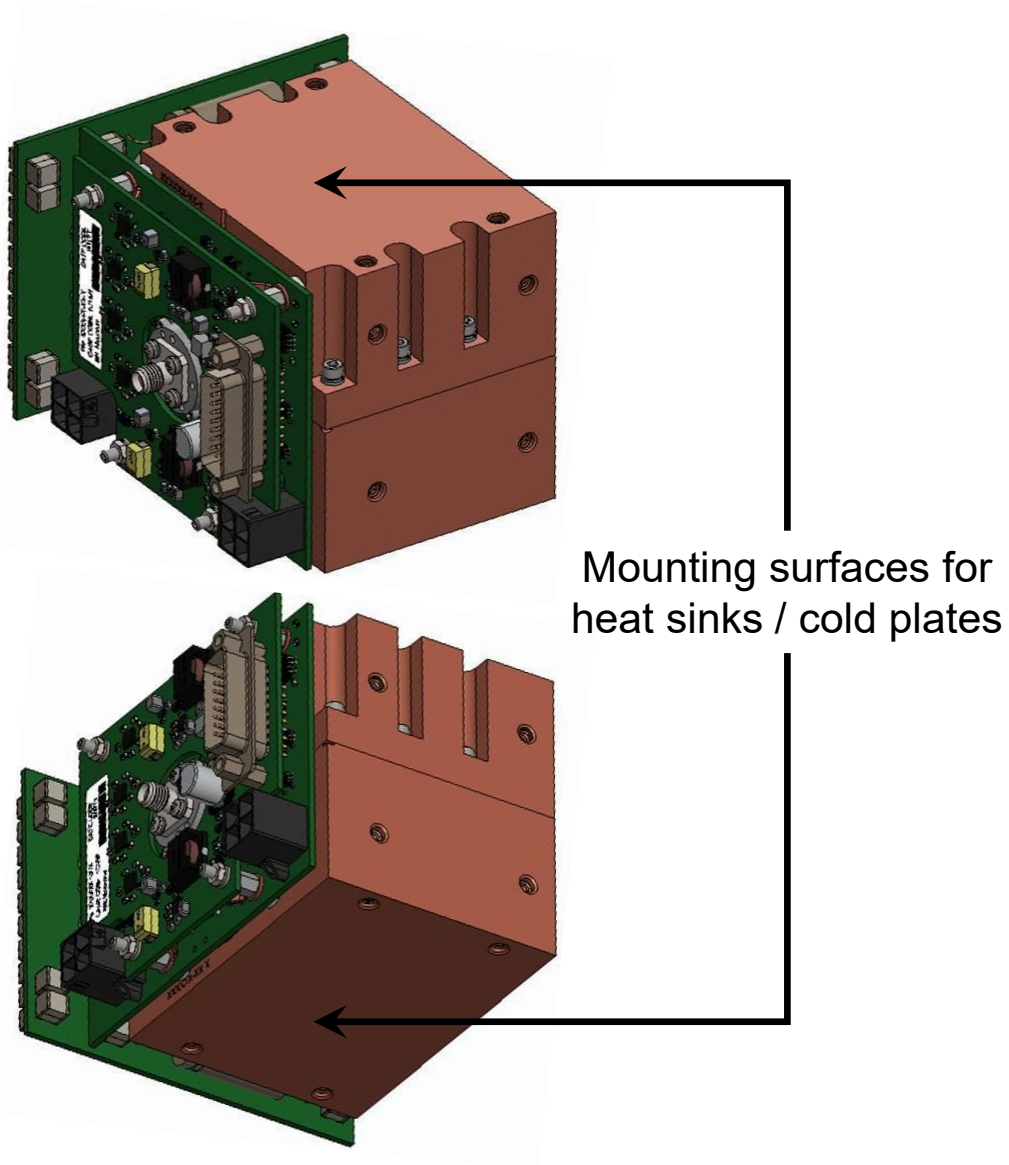

Handling Precautions



Caution!
ESD-Sensitive Device

RF VOLTAGE HAZARD: Contact with RF fields at the output connector can cause burns or electric shock. High levels of RF/Microwave energy may be present when the unit is operating.

HIGH DC CURRENT HAZARD: High levels of DC current are present when the unit is operating.

Contact Information

For the latest specifications, additional product information, worldwide sales and distribution locations:

Web: www.qorvo.com

Tel: 1-844-890-8163

Email: customer.support@qorvo.com

Important Notice

The information contained in this Data Sheet and any associated documents (“Data Sheet Information”) is believed to be reliable; however, Qorvo makes no warranties regarding the Data Sheet Information and assumes no responsibility or liability whatsoever for the use of said information. All Data Sheet Information is subject to change without notice. Customers should obtain and verify the latest relevant Data Sheet Information before placing orders for Qorvo® products. Data Sheet Information or the use thereof does not grant, explicitly, implicitly or otherwise any rights or licenses to any third party with respect to patents or any other intellectual property whether with regard to such Data Sheet Information itself or anything described by such information.

DATA SHEET INFORMATION DOES NOT CONSTITUTE A WARRANTY WITH RESPECT TO THE PRODUCTS DESCRIBED HEREIN, AND QORVO HEREBY DISCLAIMS ANY AND ALL WARRANTIES WITH RESPECT TO SUCH PRODUCTS WHETHER EXPRESS OR IMPLIED BY LAW, COURSE OF DEALING, COURSE OF PERFORMANCE, USAGE OF TRADE OR OTHERWISE, INCLUDING THE IMPLIED WARRANTIES OF MERCHANTABILITY AND FITNESS FOR A PARTICULAR PURPOSE. Without limiting the generality of the foregoing, Qorvo® products are not warranted or authorized for use as critical components in medical, life-saving, or life-sustaining applications, or other applications where a failure would reasonably be expected to cause severe personal injury or death. Applications described in the Data Sheet Information are for illustrative purposes only. Customers are responsible for validating that a particular product described in the Data Sheet Information is suitable for use in a particular application.

© 2026 Qorvo US, Inc. All rights reserved. This document is subject to copyright laws in various jurisdictions worldwide and may not be reproduced or distributed, in whole or in part, without the express written consent of Qorvo US, Inc. | QORVO® is a registered trademark of Qorvo US, Inc.