

Product Overview

The QPD1028L is a 750 W (P_{3dB}) discrete GaN on SiC HEMT which operates from 1.2 to 1.4 GHz. Input pre-match within the package results in ease of external board match and saves board space. The device is in an industry standard air cavity package. It is suitable for L-Band Military Radar applications for long pulse operations.

Evaluation boards are available upon request.



Ni-780 Package

QPD1028LEVB 65V Pulsed Performance

Freq.(GHz)	P_{3dB} (W)	G_{3dB} (dB)	DE_{3dB} (%)
1.2	782.5	15.4	59.4
1.3	759.5	15.7	57.2
1.4	789.6	15.9	61.8

Pulse Signal: Pulse Width = 1ms, Duty Cycle = 25%, $V_D = 65V$, $I_{DQ} = 750$ mA, Baseplate Temperature of 25°C

QPD1028LEVB 50V Pulsed Performance

Freq.(GHz)	P_{3dB} (W)	G_{3dB} (dB)	DE_{3dB} (%)
1.2	555.5	15.5	63.0
1.3	529.4	15.7	60.2
1.4	517.2	16.0	62.3

Pulse Signal: Pulse Width = 300us, Duty Cycle = 10%, $V_D = 50V$, $I_{DQ} = 750$ mA, Baseplate Temperature of 25°C

Functional Block Diagram

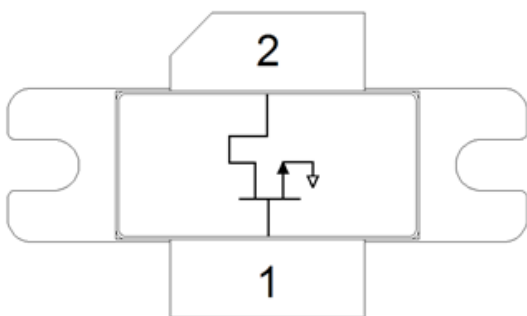

Key Features

- Frequency Range: 1.2 to 1.4 GHz
- Linear Gain¹: 19.8 dB
- Output Power (P_{3dB})¹: 838.5 W
- Drain Efficiency (P_{3dB})¹: 67.3%
- Operating Voltage: 65 V
- Long Pulse capable (e.g. 1ms-25%)
- CW capable using soldering process

Note 1: Typical EVB Performance @ 1.3 GHz, Pulse Width = 100 μ s, Duty Cycle = 10%

Applications

- Military Radar
- Civilian Radar

Ordering Information

Part No.	Description
QPD1028L	1.2 – 1.4 GHz Transistor (18 pcs in tray)
QPD1028LEVB	1.2 – 1.4 GHz Evaluation Board

Absolute Maximum Ratings^{1, 2, 3, 4}

Parameter	Rating	Units
Breakdown Voltage, BV_{DG}	225	V
Gate Voltage Range, V_G	-7 to +2	V
Drain Current, $I_{D_{MAX}}$	71	A
Gate Current, I_G	79	mA
Power Dissipation, Pulsed, P_{DISS}^2	605	W
RF Input Power, Pulsed, P_{IN}^3	45.2	dBm
Operating Channel Temperature ⁴	275	°C
Storage Temperature	-65 to +150	°C

Notes:

1. Operation of this device outside the parameter ranges given above may cause permanent damage
2. Pulsed, 100us PW, 10% DC, Package base at 85 °C
3. Pulsed, 100us PW, 10% DC, T = 25 °C, 50 ohms load
4. Package base at 85 °C

Recommended Operating Conditions^{1, 2, 3, 4}

Parameter	Min	Typ	Max	Units
Operating Temp. Range	-40	+25	+85	°C
Drain Voltage Range, V_D	-	65	-	V
Drain Bias Current, I_{DQ}	-	750	-	mA
Drain Current, I_D^4	-	19	-	A
Gate Voltage, V_G^3	-	-2.7	-	V
Power Dissipation (P_D) ⁴	-	-	400	W
Power Dissipation (P_D), CW ²	-	-	238	W

Notes:

1. Electrical performance is measured under conditions noted in the electrical specifications table. Specifications are not guaranteed over all recommended operating conditions
2. CW operates at drain voltage of 50 V
3. To be adjusted to desired I_{DQ}
4. Pulsed, 100us PW, 10% DC

Measured Load Pull Performance – 65V Power Tuned^{1, 2}

Parameter	Typical Values			Units
	1.2	1.3	1.4	
Frequency, F	1.2	1.3	1.4	GHz
Output Power at 3dB compression, P_{3dB}	59.5	59.6	59.4	dBm
Drain Efficiency at 3dB compression, $DEff_{3dB}$	62.7	63.6	63.6	%
Gain at 3dB compression, G_{3dB}	17.4	17.3	17.4	dB

Notes:

1. Test conditions unless otherwise noted: $T_A = 25\text{ °C}$, $V_D = 65\text{ V}$, $I_{DQ} = 750\text{ mA}$
2. Pulsed, 100 us Pulse Width, 10% Duty Cycle.

Measured Load Pull Performance – 65V Efficiency Tuned^{1, 2}

Parameter	Typical Values			Units
	1.2	1.3	1.4	
Frequency, F	1.2	1.3	1.4	GHz
Output Power at 3dB compression, P_{3dB}	57.7	57.9	57.4	dBm
Drain Efficiency at 3dB compression, $DEff_{3dB}$	76.0	76.7	74.4	%
Gain at 3dB compression, G_{3dB}	19.4	19.1	19.0	dB

Notes:

1. Test conditions unless otherwise noted: $T_A = 25\text{ °C}$, $V_D = 65\text{ V}$, $I_{DQ} = 750\text{ mA}$
2. Pulsed, 100 us Pulse Width, 10% Duty Cycle.

RF Characterization – 1.2 – 1.4 GHz EVB Performance at 1.3 GHz ¹

Parameter	Min	Typ	Max	Units
Linear Gain, G_{LIN}	–	19.8	–	dB
Output Power at 3dB compression point, P3dB	–	59.2	–	dBm
Drain Efficiency at 3dB compression point, DEff3dB	–	67.3	–	%
Gain at 3dB compression point, G3dB	–	16.8	–	dB
Gate Leakage, $V_D = +10$ V, $V_G = -3.3$ V	-40	–	–	mA

Notes:

1. $V_D = +65$ V, $I_{DQ} = 750$ mA, Temp = +25 °C, Pulse Width = 100 uS, Duty Cycle = 10%

RF Characterization – Mismatch Ruggedness at 1.2, 1.3, 1.4 GHz ^{1, 2, 3}

Symbol	Parameter	dB Compression	Typical
VSWR	Impedance Mismatch Ruggedness	3	10:1

Notes:

1. Test conditions unless otherwise noted: $T_A = +25$ °C, $V_D = +65$ V, $I_{DQ} = 750$ mA
2. Input drive power is determined at pulsed 3dB compression under matched condition at EVB output connector
3. Pulse Width = 100us, Duty cycle = 10%

Thermal and Reliability Information – Pulsed ¹

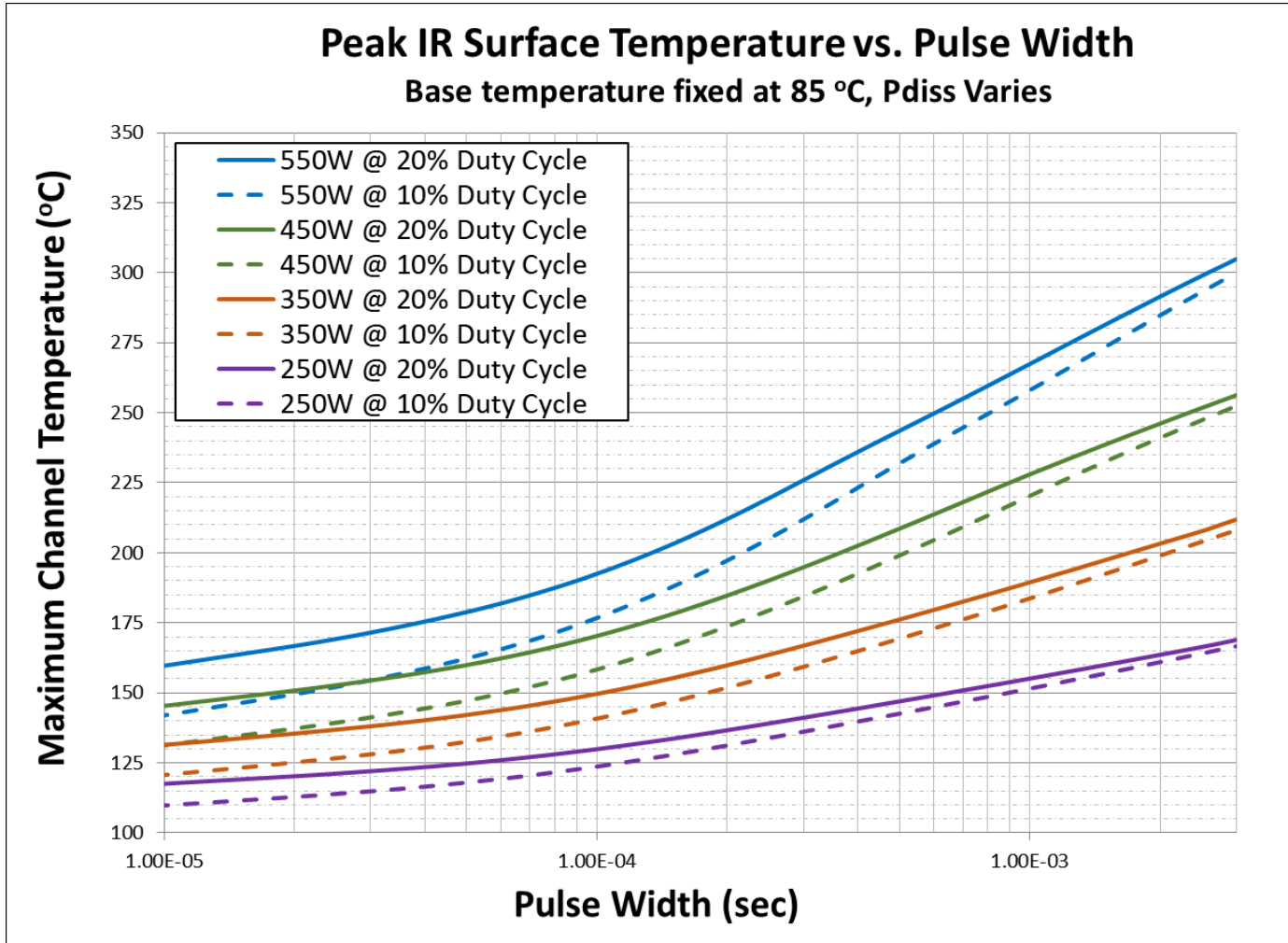

Parameter	Conditions	Values	Units
Thermal Resistance, IR ¹ (θ_{JC})	85 °C Case backside Temperature	0.21	°C/W
Peak IR Surface Temperature ¹ (T_{ch})	P _{diss} = 350 W, Pulse: 300 us PW, 10% DC	160	°C

Notes:

1. Refer to the following document [GaN Device Channel Temperature, Thermal Resistance, and Reliability Estimates](#)

Measured Load-Pull Smith Charts at 65V ^{1,2}

Notes:

1. Test Conditions: $V_D = 65\text{ V}$, $I_{DQ} = 750\text{ mA}$, 100 us Pulse Width, 10% Duty Cycle, Temp = 25°C.
2. The performance shown below is for only half of the device out of the two independent amplification paths.

1.2GHz, Load-pull

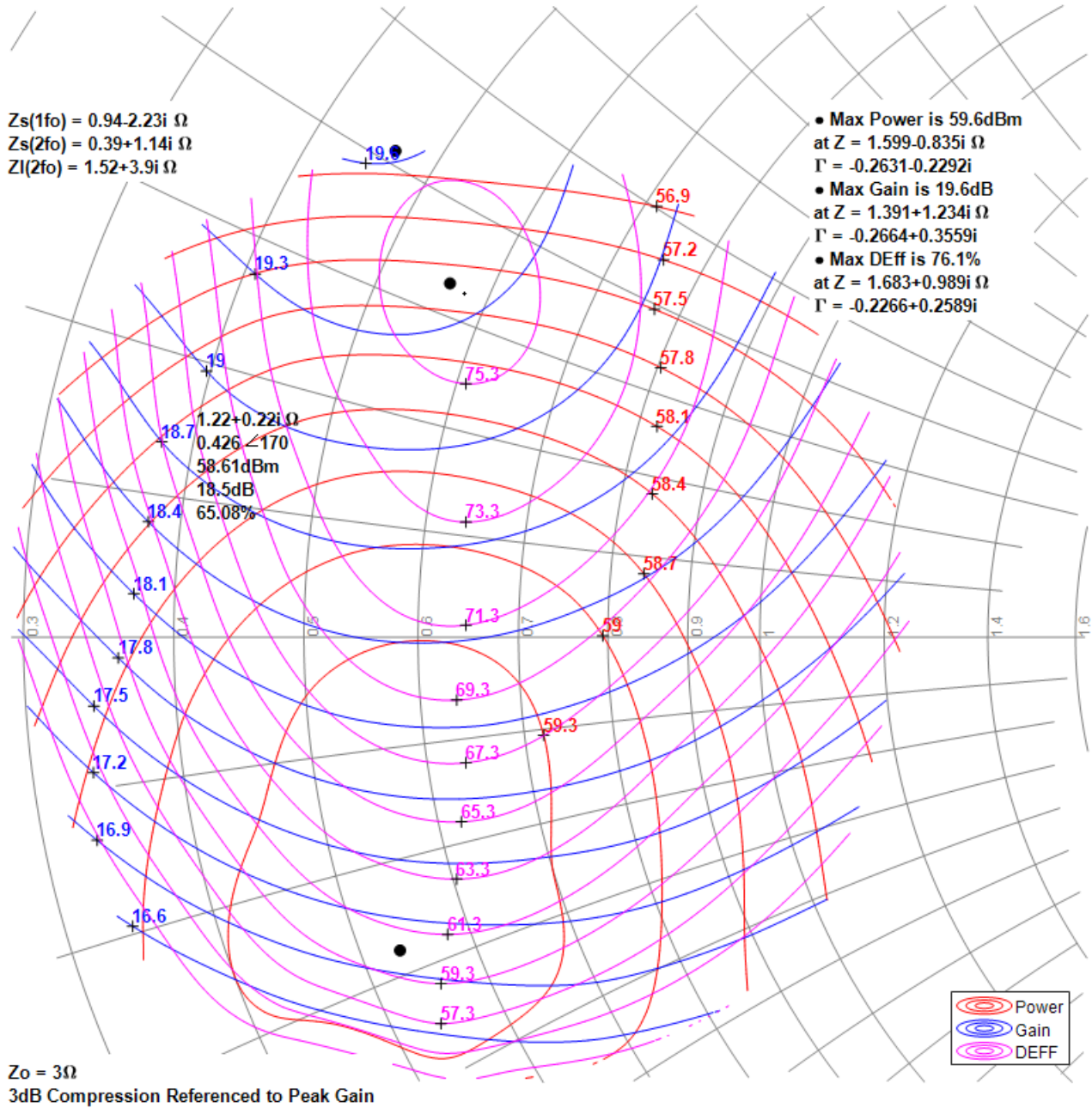

Measured Load-Pull Smith Charts at 65V ^{1,2}

Notes:

1. Test Conditions: $V_D = 65\text{ V}$, $I_{DQ} = 750\text{ mA}$, 100 us Pulse Width, 10% Duty Cycle, Temp = 25°C.
2. The performance shown below is for only half of the device out of the two independent amplification paths.

1.3GHz, Load-pull

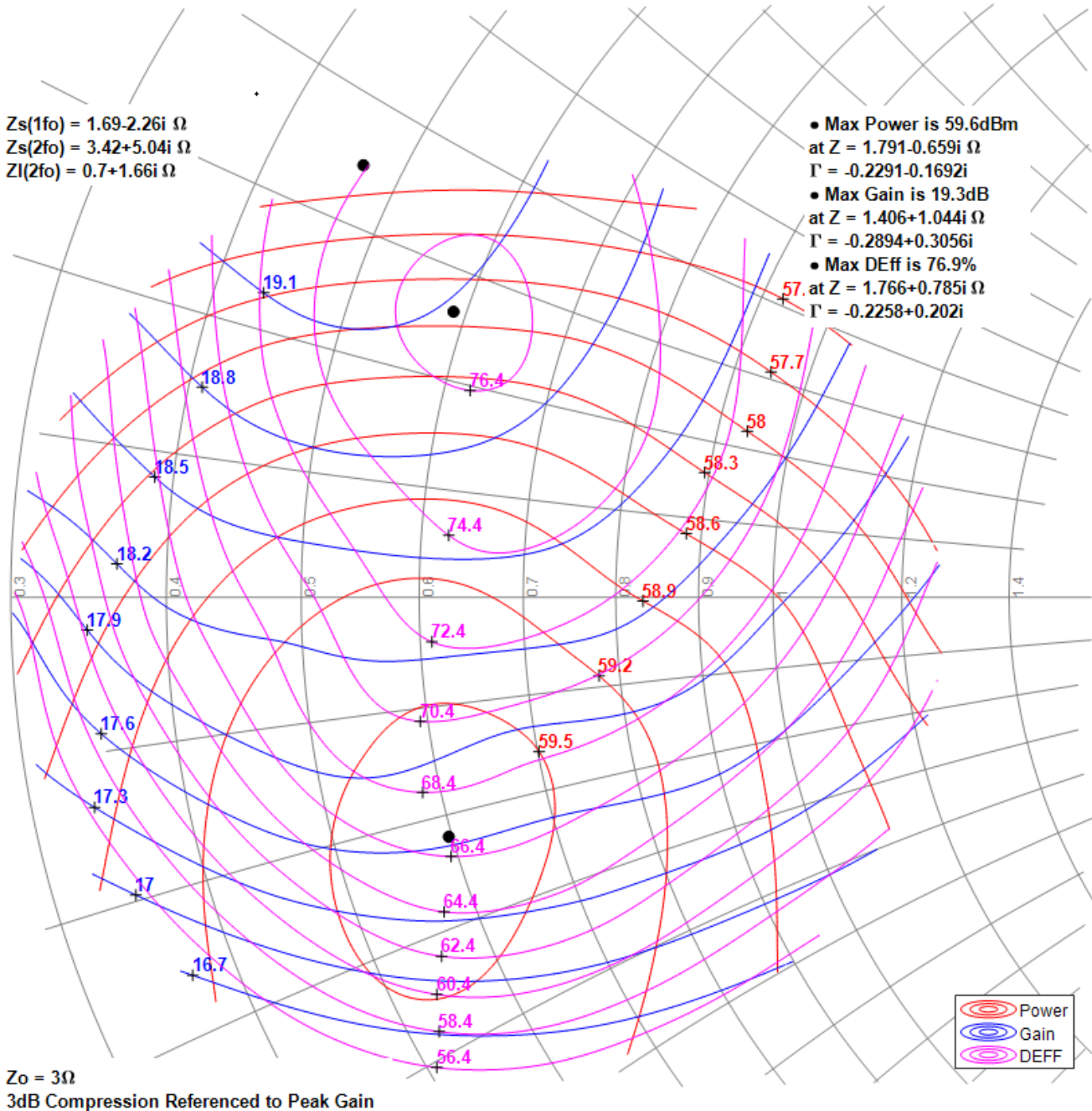

Measured Load-Pull Smith Charts at 65V ^{1, 2,}

Notes:

1. Test Conditions: $V_D = 65\text{ V}$, $I_{DQ} = 750\text{ mA}$, 100 us Pulse Width, 10% Duty Cycle, Temp = 25°C.
2. The performance shown below is for only half of the device out of the two independent amplification paths.

1.4GHz, Load-pull

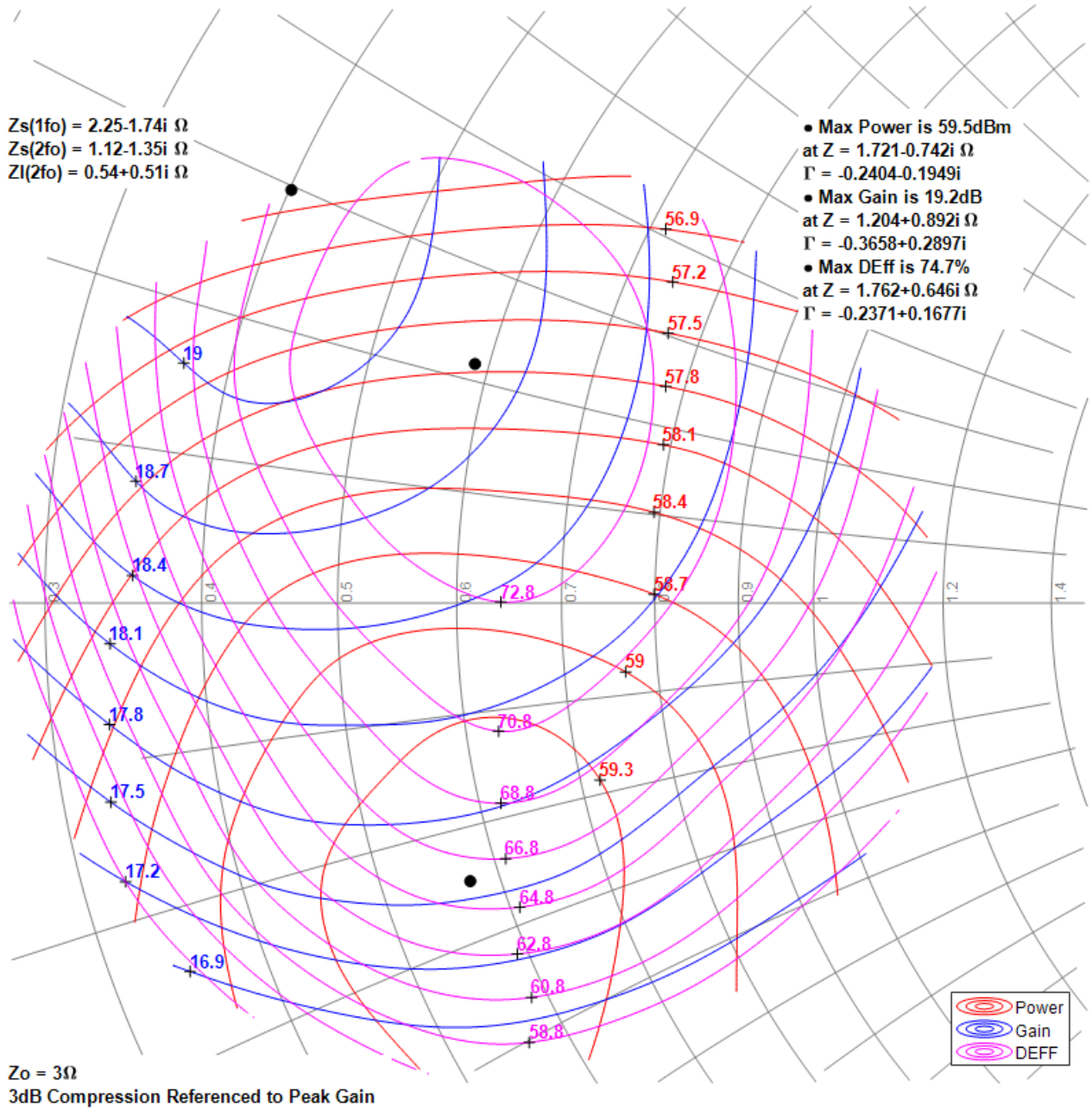

Pin Configuration and Description¹

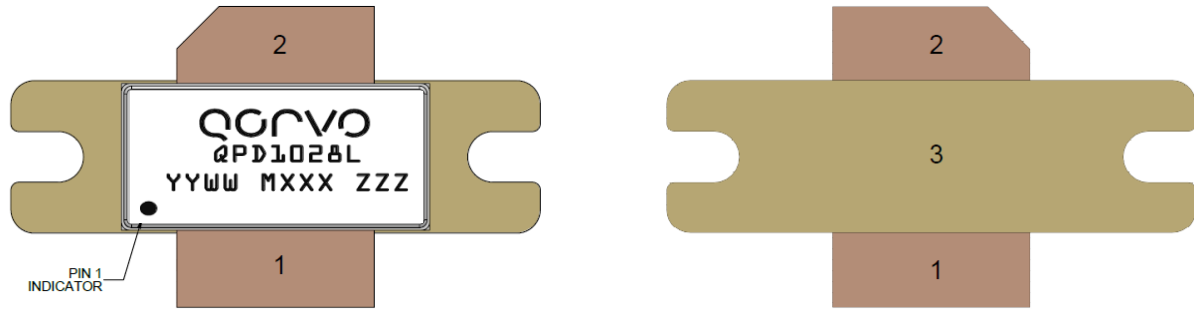

Note:

- The QPD1028L will be marked with the “QPD1028L” designator and a lot code marked below the part designator. The “YY” represents the last two digits of the calendar year the part was manufactured, the “WW” is the work week of the assembly lot start, the “MXXX” is the production lot number, and the “ZZZ” is an auto-generated serial number.

Pin	Symbol	Description
1	RF IN / V _G	Gate
2	RF OUT / V _D	Drain
3	Source	Source / Ground / Backside of part

Mechanical Drawing¹⁻⁷

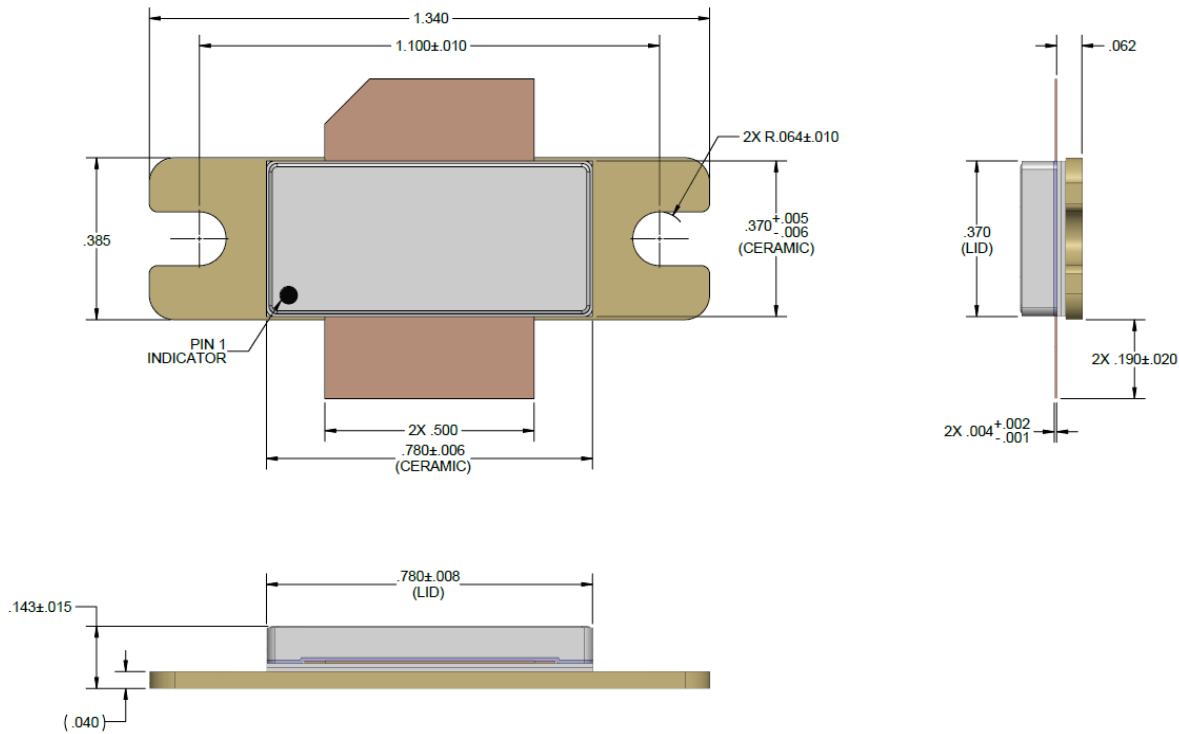

Notes:

1. All dimensions are in inches.
2. Dimension tolerance is ± 0.005 inches, unless noted otherwise.
3. Package Base: Ceramic/Metal, Package Lid: Ceramic.
4. Package exposed metallization is gold plated.
5. Part is epoxy sealed.
6. Part meets industry NI780 footprint.
7. Body dimensions do not include lid shift or epoxy run out which can be up to 0.020 inches per side.

1.2 – 1.4 GHz Application Circuit - Schematic

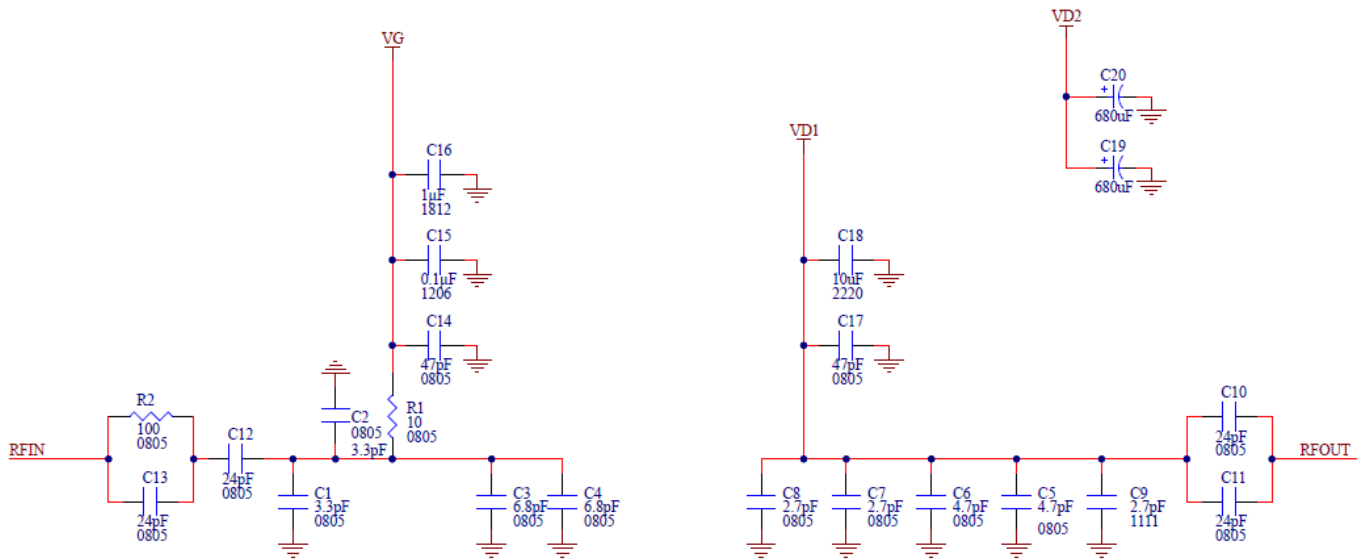

Biasing Procedure

Bias On

1. Turn ON V_G to -5 V.
2. Turn ON V_D to $+65$ V.
3. Slowly adjust V_G until $I_D = 750$ mA.
(Typically, $V_G = -2.8$ V.)
4. Turn ON RF.

Bias Off

1. Turn OFF RF.
2. Adjust V_G to -5 V.
3. Turn OFF V_D .
4. Wait two (2) seconds to allow drain capacitors to discharge.
5. Turn OFF V_G .

1.2 – 1.4 GHz Application Circuit – EVB Assembly ^{1,2}

Notes:

1. PCB material is RO4350B 0.030" thick, 2 oz. copper each side.
2. EVB is rated for pulsed operation only.

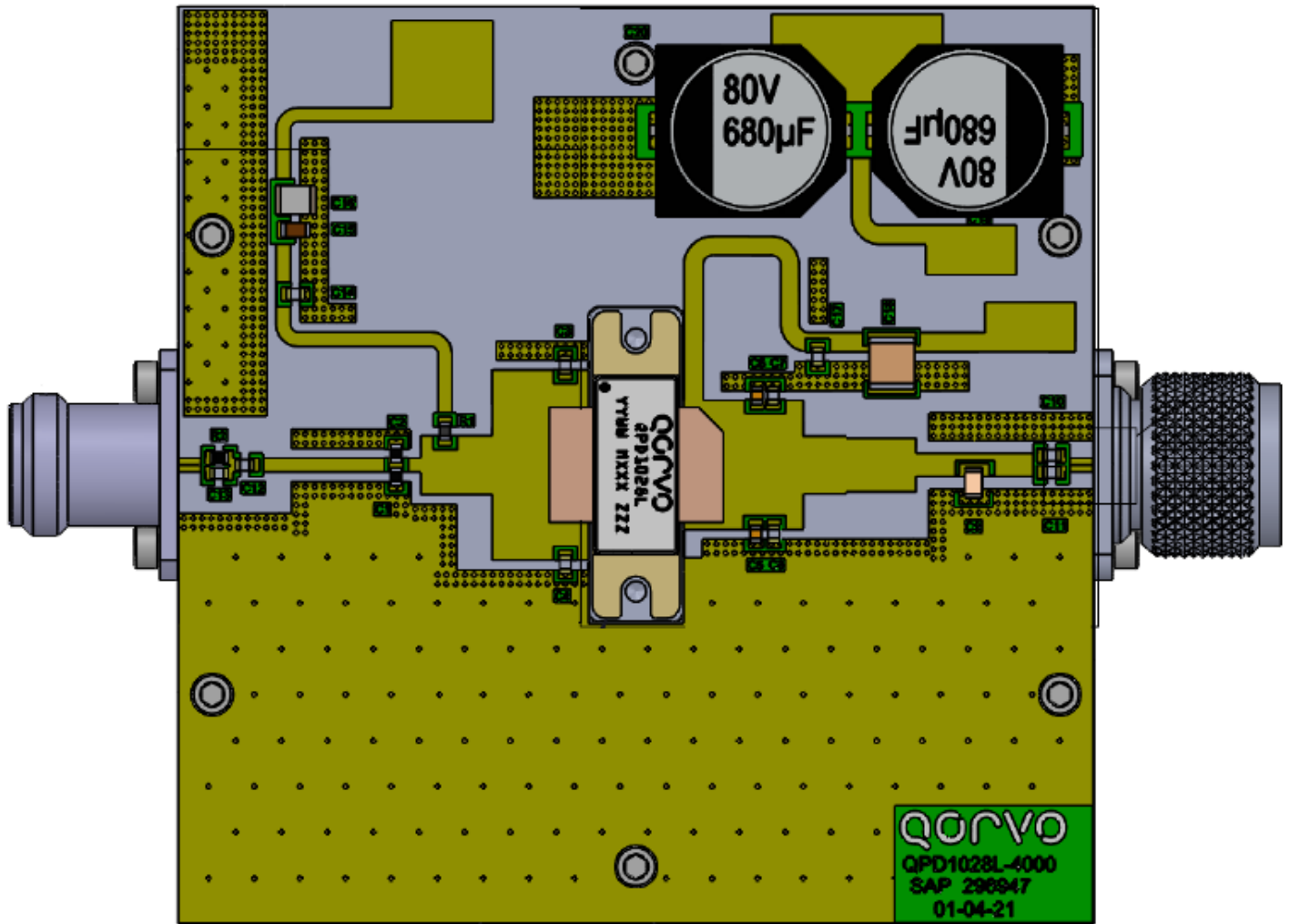



1.2 – 1.4 GHz Application Circuit EVB – Bill of Material

Ref Des	Qty	Description	Mfg Name	Mfg Part #
U1	1	750W, 65V, Pre-matched, 1.2-1.4GHz	Qorvo	QPD1028L
C1, C2	2	CAP, 3.3pF, 0.1pF, 250V, C0G, 0805	American Technical Ceramics	600F3R3BT250XT
C3, C4	2	CAP, 6.8pF, ± 0.1pF, 250V, C0G, 0805	American Technical Ceramics	600F6R8BTT250XT
C5, C6	2	CAP, 4.7pF, 0.1pF, 250V, C0G, 0805	American Technical Ceramics	600F4R7BT250XT
C7, C8	2	CAP, 2.7pF, 0.1pF, 250V, C0G, 0805	American Technical Ceramics	600F2R7BT250XT
C9	1	CAP, 2.7pF, ±0.1pF, 500V, C0G, ATC-B	American Technical Ceramics	800B2R7BT500X
C10, C11, C12, C13	4	CAP, 24pF, 1%, 250V, C0G, 0805	American Technical Ceramics	600F240FT250XT
C14, C17	2	CAP, 47pF, 5%, 250V, HI-Q, 0805	American Technical Ceramics	600F470JT250XT
C15	1	CAP, 0.1uF, 10%, 100V, X7R, 1206	AVX Corporation	12061C104K4T2A
C16	1	CAP, 1uF, 10%, 100V, STD, 1812	AVX Corporation	18121C105KAT2A
C18	1	CAP, 10uF, 20%, 100V, X7S, 2220	TDK Singapore LTD	C5750X7S2A106M230KB
C19, C20	2	CAP, 680uF, ±20%, 80V, Alum Cap, SMD	Vishay Americas, Inc	MAL215099708E3
R1	1	RES, 10 OHM, 1%, 1/8W, 0805	Panasonic Industrial	ERJ-6ENF10R0V
R2	1	RES, 100 OHM, 5%, 1/8w, 0805	Kamaya, Inc	RMC1/10-101JTP
RFOUT	1	CONN, N, RECP ST PANEL FLG MNT	HUBER+SUHNER, Inc.	23_N-50-0-33/133_NE
RFIN	1	CONN, COAXIAL, 11 GHz, N-FLANGE, FEMALE	HUBER+SUHNER, Inc.	23_N-50-0-33/133_NE

P3dB Performance over Temperature of 1.2 – 1.4 GHz EVB ¹

Notes:

1. Test Conditions: $V_D = 65\text{ V}$, $I_{DQ} = 750\text{ mA}$, 100 us Pulse Width, 10% Duty Cycle.

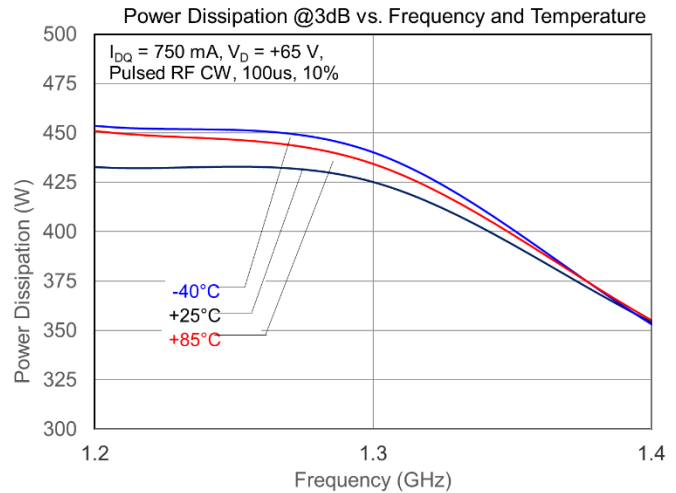
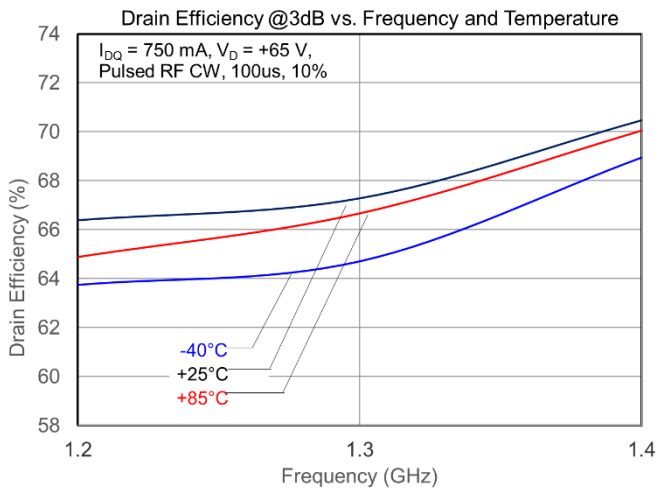
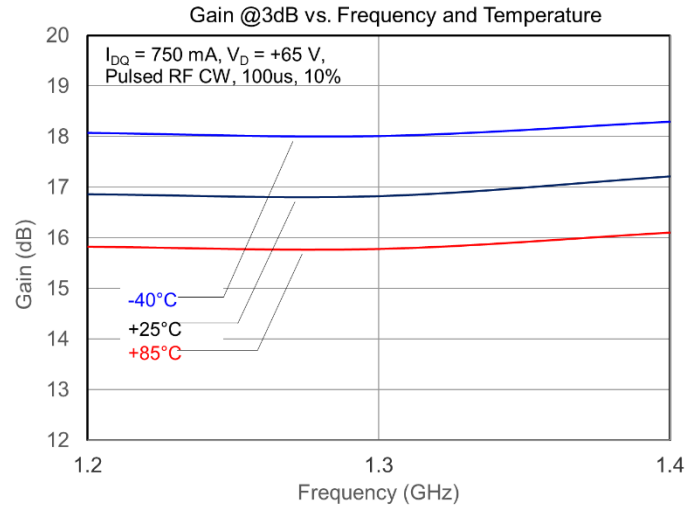
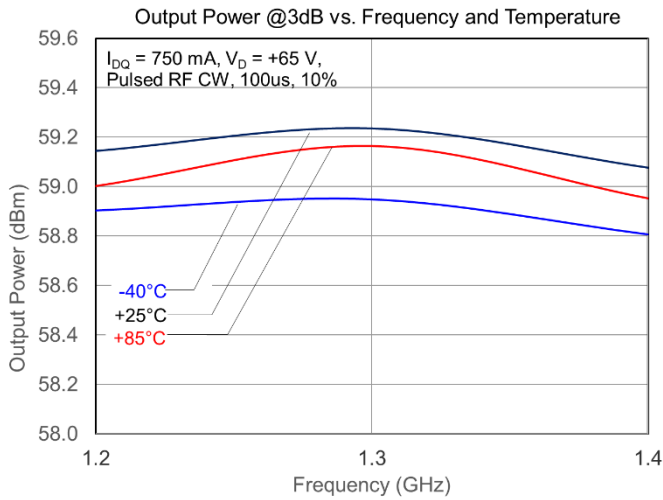

Power Drive-up Performance over Temperatures of 1.2 – 1.4 GHz EVB ¹

Notes:

1. Test Conditions: $V_D = 65\text{ V}$, $I_{DQ} = 750\text{ mA}$, 100 μs Pulse Width, 10% Duty Cycle.

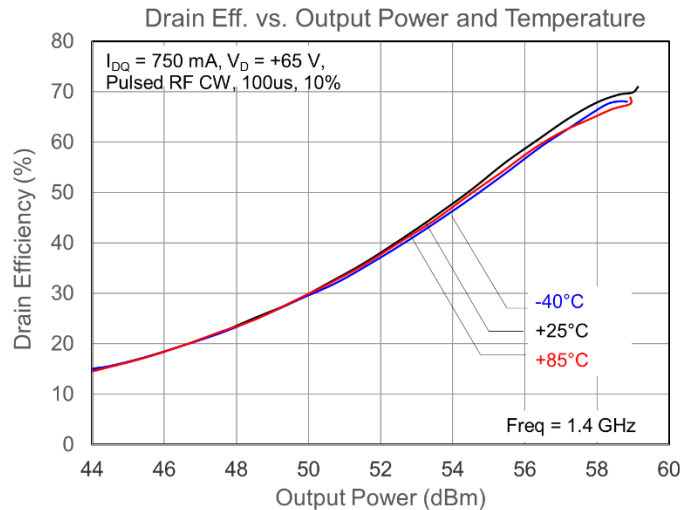
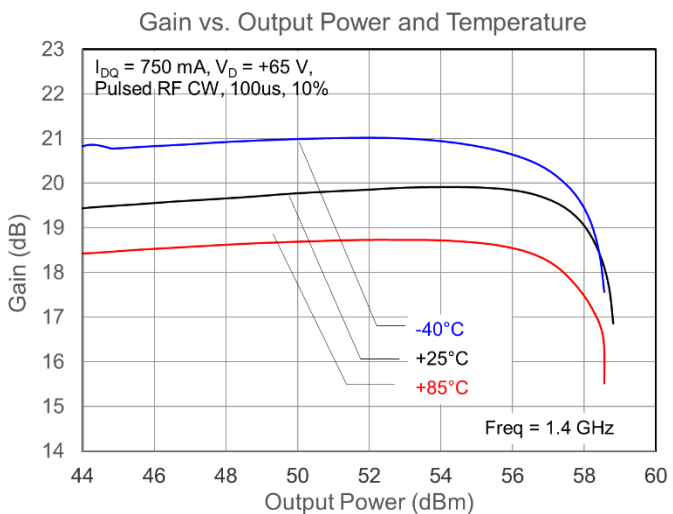
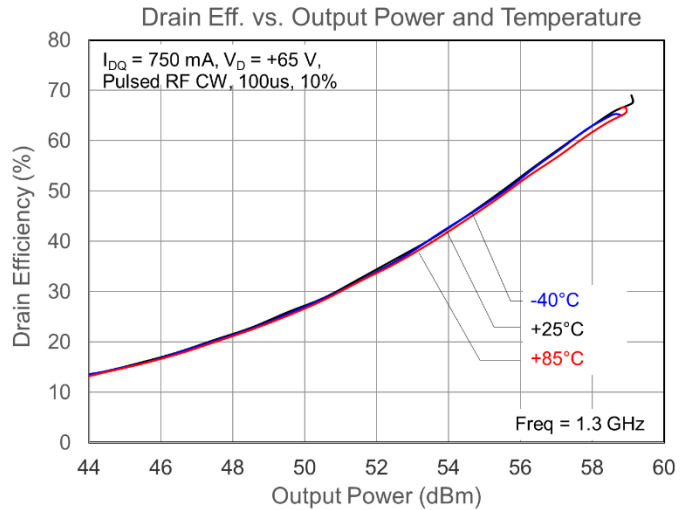
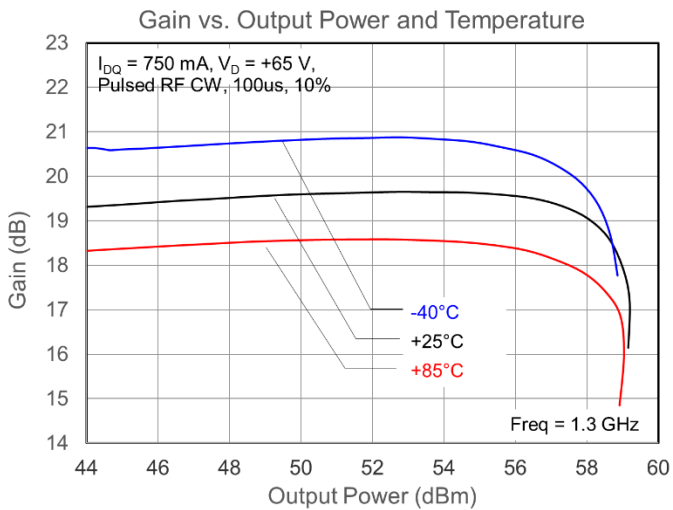
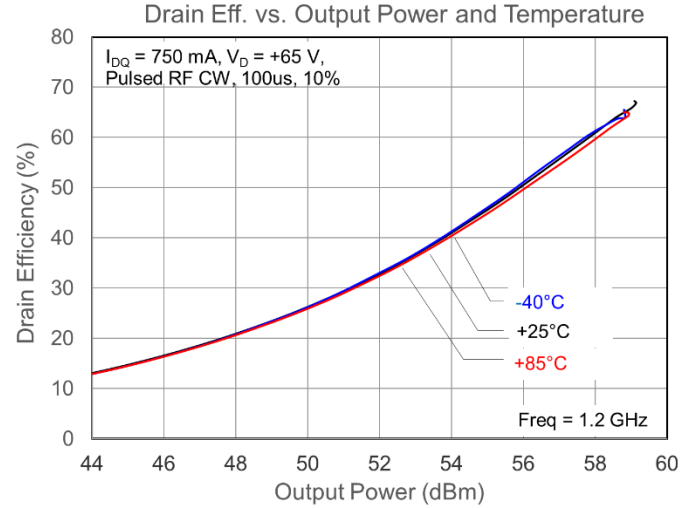
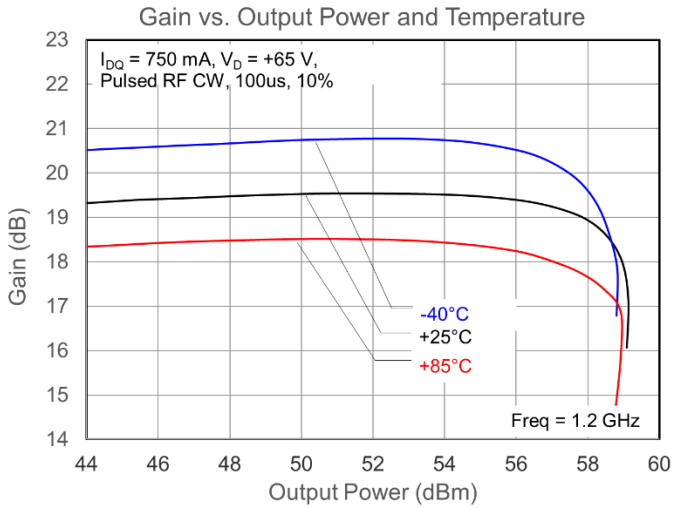

Recommended Solder Temperature Profile

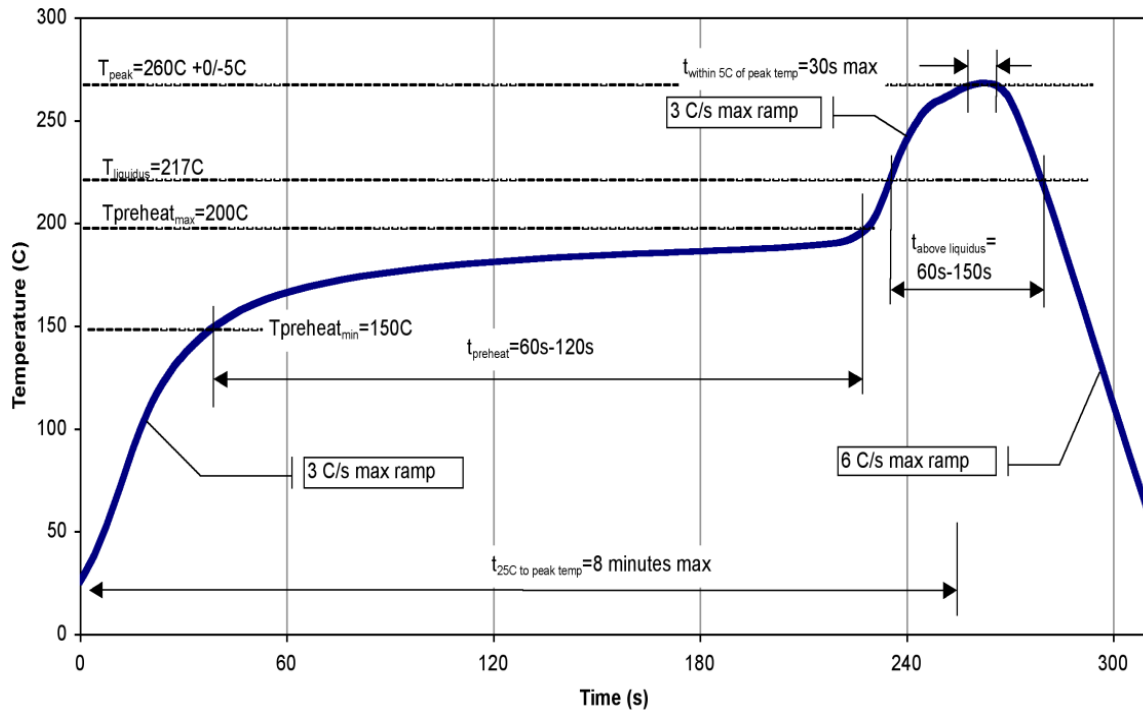

Handling Precautions

Parameter	Rating	Standard
ESD – Human Body Model (HBM)	Class 1A (250V)	ANSI/ESDA/JEDEC Standard JS-001
ESD – Charged Device Model (CDM)	Class C3 (1000V)	ANSI/ESDA/JEDEC Standard JS-002
MSL – Moisture Sensitivity Level	MSL3	IPC/JEDEC Standard J-STD-020



Caution!
ESD-Sensitive Device

Solderability

Compatible with both lead-free (260°C max. reflow temp.) and tin/lead (245°C max. reflow temp.) soldering processes.

Package lead plating is NiAu. Au thickness is 60 micro inches minimum.

RoHS Compliance

This part is compliant with 2011/65/EU RoHS directive (Restrictions on the Use of Certain Hazardous Substances in Electrical and Electronic Equipment) as amended by Directive 2015/863/EU.

This product also has the following attributes:

- Halogen Free (Chlorine, Bromine)
- Antimony Free
- TBBP-A (C₁₅H₁₂Br₄O₂) Free
- PFOS Free
- SVHC Free

Contact Information

For the latest specifications, additional product information, worldwide sales and distribution locations:

Web: www.qorvo.com

Tel: 1-844-890-8163

Email: customer.support@qorvo.com

Important Notice

The information contained herein is believed to be reliable; however, Qorvo makes no warranties regarding the information contained herein and assumes no responsibility or liability whatsoever for the use of the information contained herein. All information contained herein is subject to change without notice. Customers should obtain and verify the latest relevant information before placing orders for Qorvo products. The information contained herein or any use of such information does not grant, explicitly or implicitly, to any party any patent rights, licenses, or any other intellectual property rights, whether with regard to such information itself or anything described by such information. **THIS INFORMATION DOES NOT CONSTITUTE A WARRANTY WITH RESPECT TO THE PRODUCTS DESCRIBED HEREIN, AND QORVO HEREBY DISCLAIMS ANY AND ALL WARRANTIES WITH RESPECT TO SUCH PRODUCTS WHETHER EXPRESS OR IMPLIED BY LAW, COURSE OF DEALING, COURSE OF PERFORMANCE, USAGE OF TRADE OR OTHERWISE, INCLUDING THE IMPLIED WARRANTIES OF MERCHANTABILITY AND FITNESS FOR A PARTICULAR PURPOSE.**

Without limiting the generality of the foregoing, Qorvo products are not warranted or authorized for use as critical components in medical, life-saving, or life-sustaining applications, or other applications where a failure would reasonably be expected to cause severe personal injury or death.

Copyright 2026 © Qorvo, Inc. | Qorvo is a registered trademark of Qorvo, Inc.