

### General Description

The QPQ3509 is an exceptionally high-performance BAW 280 MHz band pass Filter. This filter is housed in a compact 2.0 x 1.6 mm package for base station applications.

Low insertion loss coupled with high attenuation makes this filter an ideal choice for US 5G applications of Small Cell and Radio DOT system.

The QPQ3509 is part of Qorvo’s extensive portfolio of RF BAW and SAW filters.



3 Pin 2.0 x 1.6 mm leadless SMT Package

### Functional Block Diagram

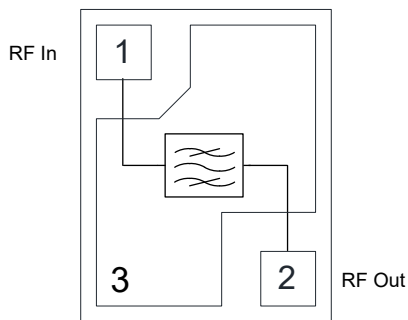

Top View

### Pin Configuration

Pin No.	Label
1	RF In
2	RF Out
3	GND Back Side Paddle

### Product Features

- 3.70 GHz – 3.98 GHz
- 280 MHz Bandwidth
- High Attenuation
- Low Loss
- No External Matching Required
- Excellent Wi-Fi Rejection
- Single Ended Input & Output Operation
- Small Size: 2.00 x 1.60 x 0.89 mm
- Surface Mount Device
- RoHS Compliant, Pb-Free

### Applications

- Base Station Infrastructure
- Small Cells
- Radio DOT
- Repeaters
- Routers
- LTE Dongles
- General Purpose Wireless

### Ordering Information

Part	Description
QPQ3509TR7	2500 pieces on a 7" Reel.
QPQ3509SR	100 pieces on a 7" Sample Reel.
QPQ3509EV01	Evaluation Board – QPQ3509

## Absolute Maximum Ratings

Parameter	Rating
Storage Temperature	-40 to +125 °C
RF Input Power PW = 500ms; DC = 50% @ +25 °C	+36.5 dBm

Exceeding any one or a combination of the Absolute Maximum Rating conditions may cause permanent damage to the device. Extended application of Absolute Maximum Rating conditions to the device may reduce device reliability.

## Recommended Operating Conditions

Operation Parameter	Min	Max
Operation Temperature	-40°C	+95°C
RF Input Power, ≥10-year Lifetime <sup>(1)</sup>		+30.5 dBm

Note:

1. NR TM3.1, 20 MHz, 64 QAM, PAR 9 dB, +95°C

## Electrical Specifications

Test Conditions unless otherwise noted, Temperature = -40°C to +95°C

Parameter	Conditions <sup>(1)</sup> <sup>(2)</sup>	Min	Typ. <sup>(3)</sup>	Max	Unit
Frequency Range		3700	-	3980	MHz
Integrated Insertion Loss	3700 – 3720 MHz	-	2.7	3.5	dB
	3720 – 3960 MHz, 20 MHz window	-	2.2	3.5	
	3960 – 3980 MHz	-	2.4	3.5	
Amplitude Variation	3700 – 3720 MHz	-	0.7	2	dB p-p
	3720 – 3960 MHz	-	1.0	2	
	3960 – 3980 MHz	-	0.5	2	
Input VSWR	3700 – 3980 MHz	-	1.6	2.0	-
Output VSWR	3700 – 3980 MHz	-	1.6	2.0	-
2 <sup>nd</sup> Harmonic <sup>(4)</sup>	CW tone at center of passband, Pin = +30.5dBm, +25°C, Pin1	-	-80	-	dBc

Notes:

1. In production, devices will be tested at room temperature to a guard banded specification to ensure compliance over temperature
2. Electrical margin has been built into the design to account for variations due to temperature drift and manufacturing tolerances
3. Typical values are based on average measurements at room temperature
4. Guaranteed by design

## Electrical Specifications (Continued)

Test Conditions unless otherwise noted, Temperature = -40°C to +95°C

Parameter	Conditions <sup>(1) (2)</sup>	Min	Typ. <sup>(3)</sup>	Max	Unit
Attenuation <sup>(4)</sup>	100 – 450 MHz	45	54.3	-	dB
	470 – 940 MHz	35	49.3	-	dB
	1160 – 1300 MHz	40	48.0	-	dB
	1390 – 1435 MHz	40	47.9	-	dB
	1525 – 1559 MHz	20	37.6	-	dB
	1559 – 1610 MHz	35	46.8	-	dB
	1610 – 1710 MHz	30	47.7	-	dB
	1710 – 1915 MHz	40	47.7	-	dB
	1915 – 2320 MHz	30	48.1	-	dB
	2320 – 2345 MHz	40	50.3	-	dB
	2345 – 2370 MHz	30	50.6	-	dB
	2370 – 2390 MHz	40	50.7	-	dB
	2400 – 2483.5 MHz	30	51.0	-	dB
	2483.5 – 2900 MHz	43	52.1	-	dB
	2690 – 3400 MHz	45	51.9	-	dB
	3100 – 3400 MHz	45	51.9	-	dB
	3400 – 3550 MHz	35	52.8	-	dB
	3550 – 3590 MHz	20	41.4	-	dB
	4070 – 4200 MHz	40	57.4	-	dB
	4900 – 5091 MHz	35	41.8	-	dB
	5150 – 10200 MHz <sup>(5)</sup>	30	37.5	-	dB
	10200 – 11000 MHz <sup>(5)</sup>	10	16.0	-	dB
	11000 – 11200 MHz <sup>(5)</sup>	30	37.3	-	dB
11200 – 11700 MHz <sup>(5)</sup>	25	31.6	-	dB	
11700 – 12200 MHz <sup>(5)</sup>	20	25.2	-	dB	
12200 – 12750 MHz <sup>(5)</sup>	10	17.5	-	dB	

**Notes:**

1. In production, devices will be tested at room temperature to a guard banded specification to ensure compliance over temperature
2. Electrical margin has been built into the design to account for variations due to temperature drift and manufacturing tolerances
3. Typical values are based on average measurements at room temperature
4. Attenuation is referenced to ZERO dB
5. Guaranteed by design for frequency above 8000 MHz

Evaluation Board – QPQ3509EVB01

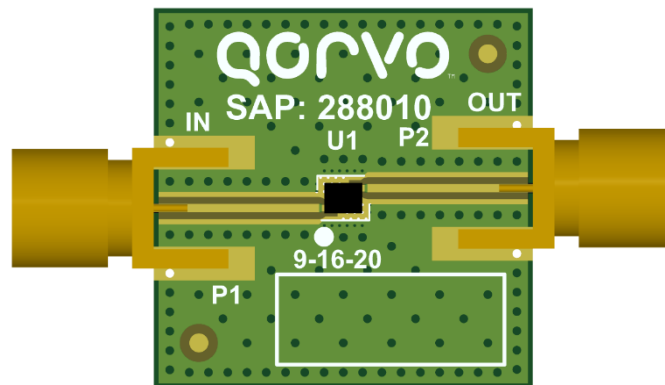
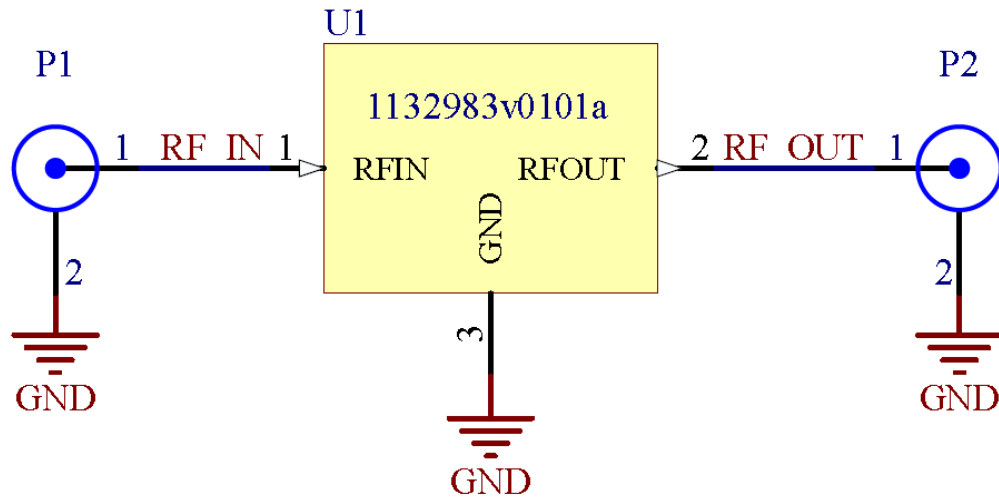

EVB TOP SIDE

**Performance Plots – QPQ3509EVB01**

Test conditions unless otherwise noted: 50 Ω system, Temperature +25°C

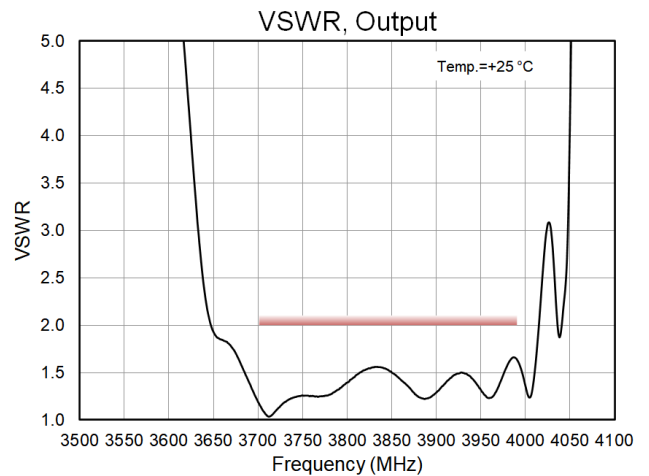
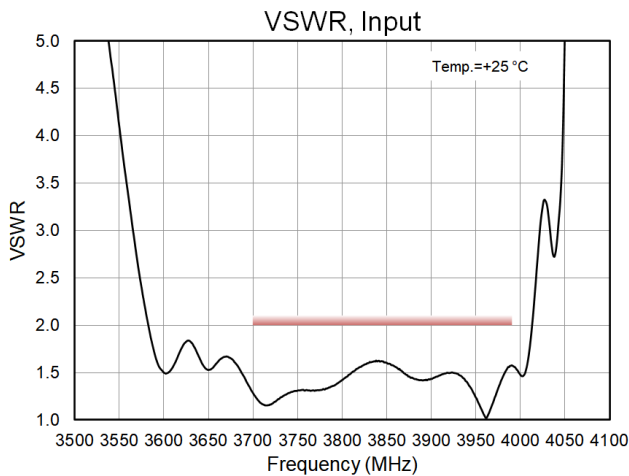
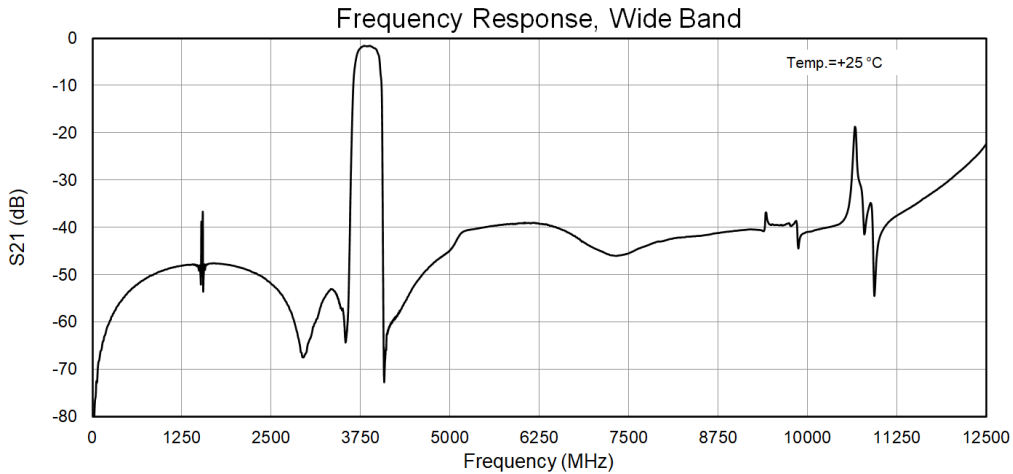
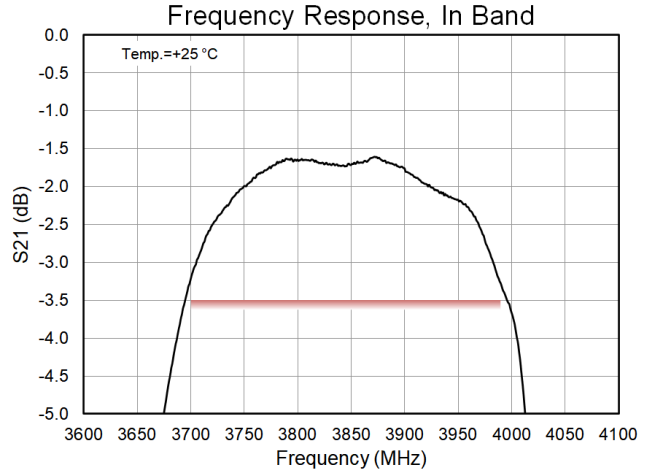
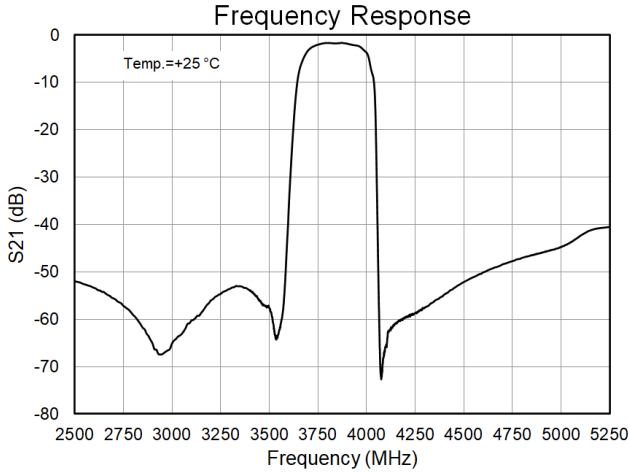

Performance Plots – QPQ3509EVB01

Test conditions unless otherwise noted: 50 Ω system, Temperature +25°C

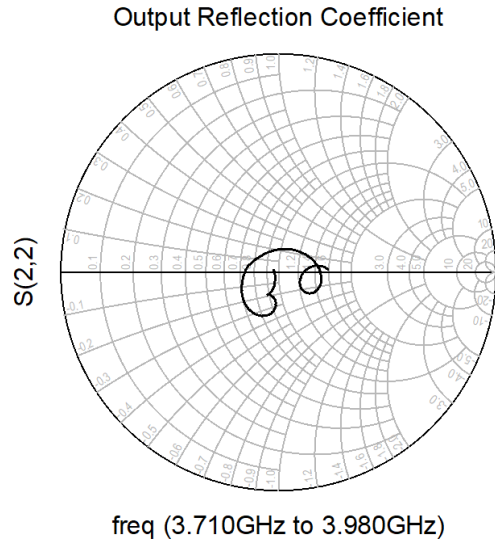
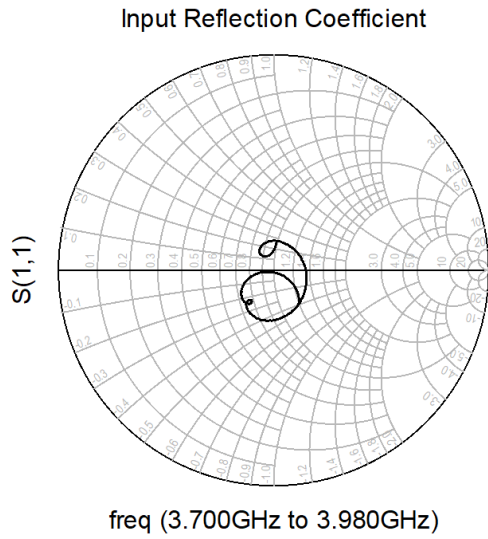

## Package Marking and Dimensions

- Marking:**
- - Pin 1 indicator
  - 3509 - Last 4 digits of the part number
  - 2DID - Trace Information

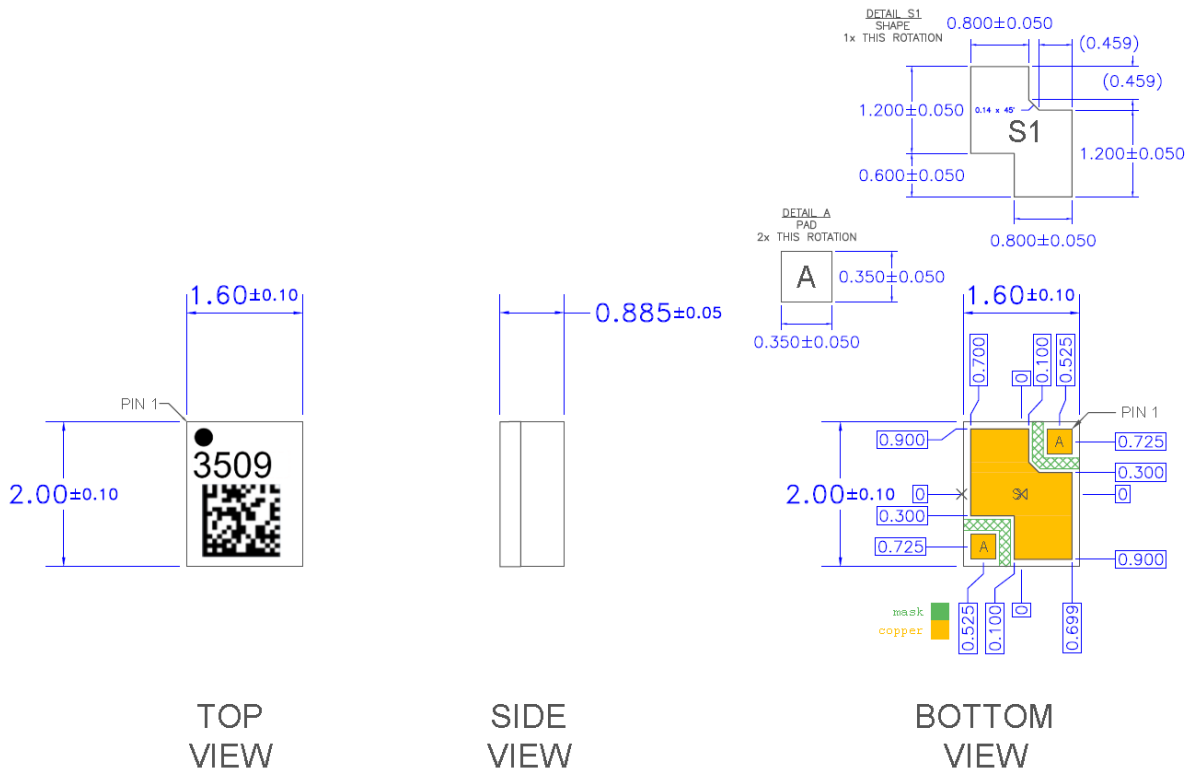

**Notes:**

1. All dimensions are in millimeters. Angles are in degrees.
2. Dimension and tolerance formats conform to ASME Y14.4M-1994.
3. The terminal #1 identifier and terminal numbering conform to JESD 95-1 SPP-012.

**PCB Mounting Pattern**

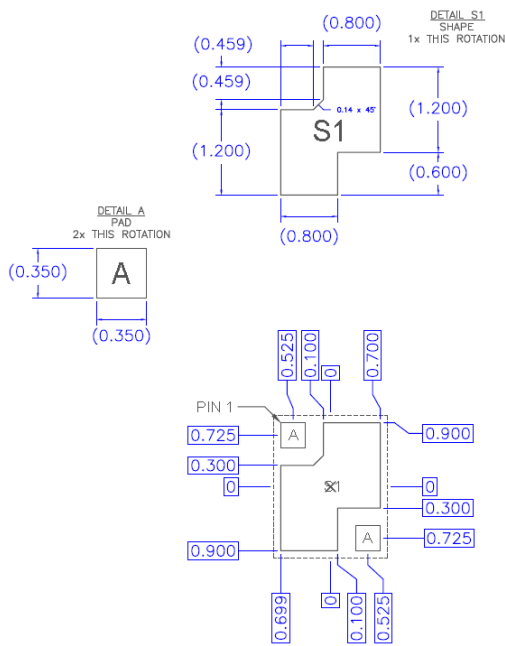

**RECOMMENDED  
 LAND PATTERN**

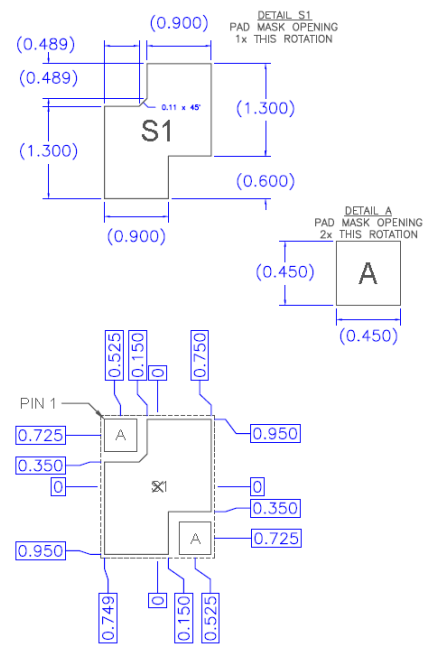

**RECOMMENDED  
 LAND PATTERN MASK**

**Notes:**

1. All dimensions are in millimeters.
2. This drawing specifies the mounting pattern used on the Qorvo evaluation board for this product. Some modification may be necessary to suit end user assembly materials and processes.

**Tape and Reel Information – Carrier and Cover Tape Dimensions**

Tape and reel specifications for this part are also available on the Qorvo website.  
 Standard T/R size = 2500 pieces on a 7” reel.

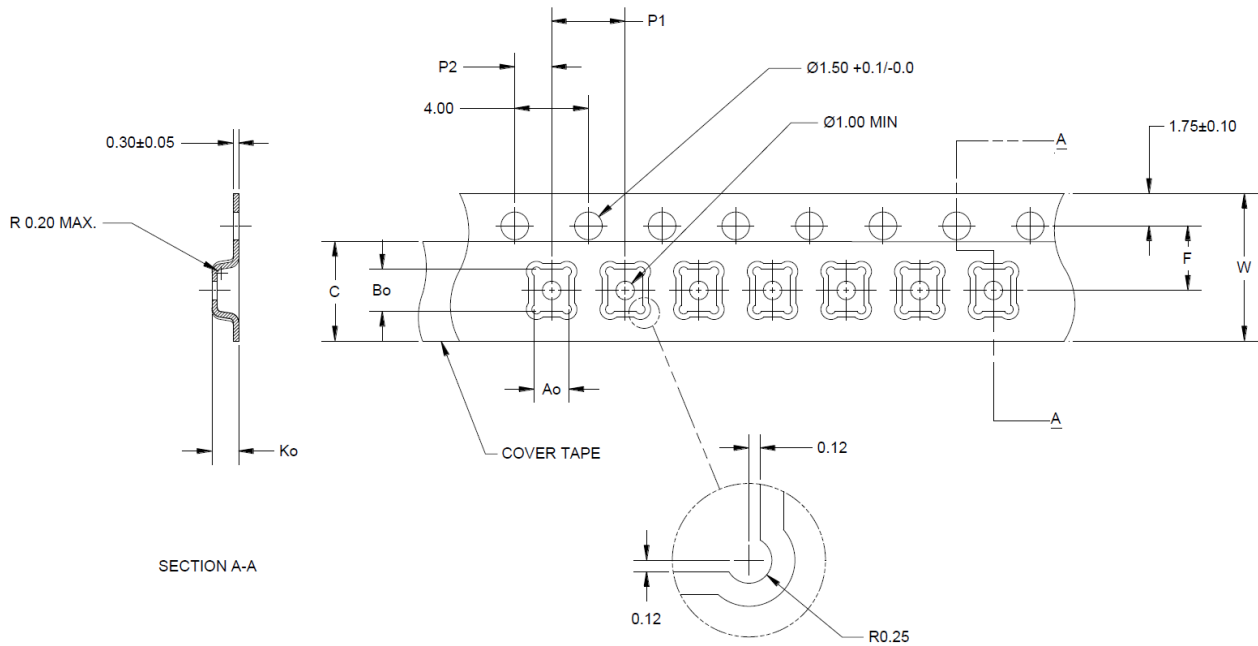

Feature	Measure	Symbol	Size (in)	Size (mm)
Cavity	Length	A0	0.077	1.95
	Width	B0	0.093	2.35
	Depth	K0	0.045	1.15
	Pitch	P1	0.157	4.00
Centerline Distance	Cavity to Perforation - Length Direction	P2	0.079	2.00
	Cavity to Perforation - Width Direction	F	0.138	3.50
Cover Tape	Width (Reference only)	C	0.213	5.40
Carrier Tape	Width	W	0.315	8.00

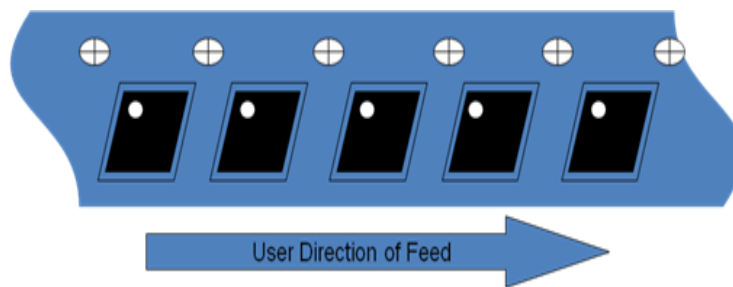

**Tape and Reel Information – Reel Dimensions**

Tape and reel specifications for this part are also available on the Qorvo website.  
Standard T/R size = 2500 pieces on a 7" reel.

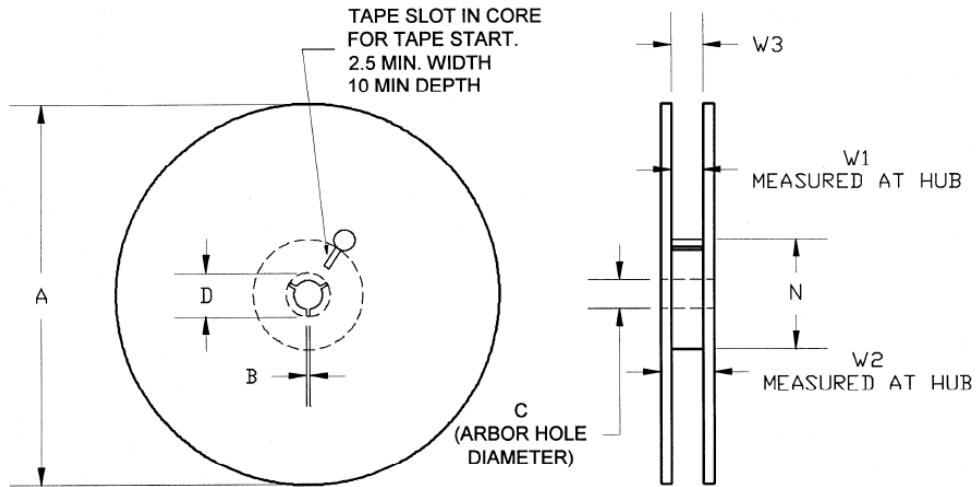

Feature	Measure	Symbol	Size (in)	Size (mm)
Flange	Diameter	A	6.969	177.0
	Thickness	W2	0.559	14.2
	Space Between Flange	W1	0.346	8.8
Hub	Outer Diameter	N	2.283	58.0
	Arbor Hole Diameter	C	0.512	13.0
	Key Slit Width	B	0.079	2.0
	Key Slit Diameter	D	0.787	20.0

**Tape and Reel Information – Tape Length and Label Placement**

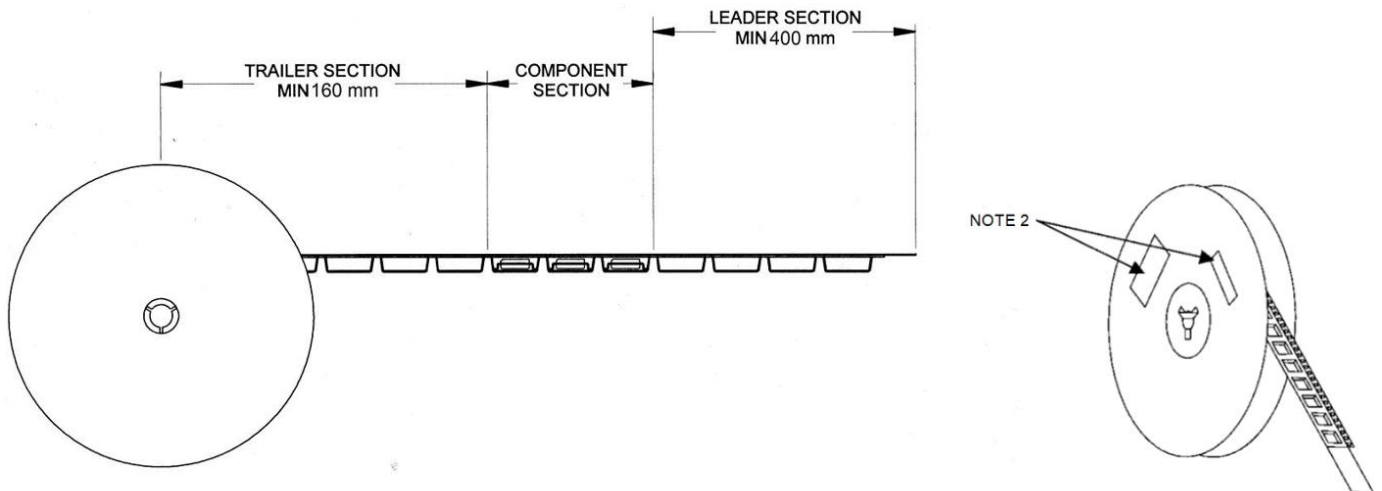

- Notes:
1. Empty part cavities at the trailing and leading ends are sealed with cover tape. See EIA 481-1-A.
  2. Labels are placed on the flange opposite the sprockets in the carrier tape.

## Handling Precautions

Parameter	Rating	Standard
ESD – Human Body Model (HBM)	Class 1B	ANSI / ESD / JEDEC JS-001
ESD – Charged Device Model (CDM)	Class C3	ANSI / ESD / JEDEC JS-002
MSL – Moisture Sensitivity Level	Level 3	IPC/JEDEC J-STD-020



Caution!  
ESD-Sensitive Device

## Solderability

Compatible with both lead-free (260°C max. reflow temp.) and tin/lead (245°C max. reflow temp.) soldering processes. Solder profiles available upon request.

Contact plating: ENEPIG (Thickness: Ni 0.40±0.10 µm; Pd 0.145±0.035 µm; Au 0.095±0.025 µm)

## Recommended Soldering Profile

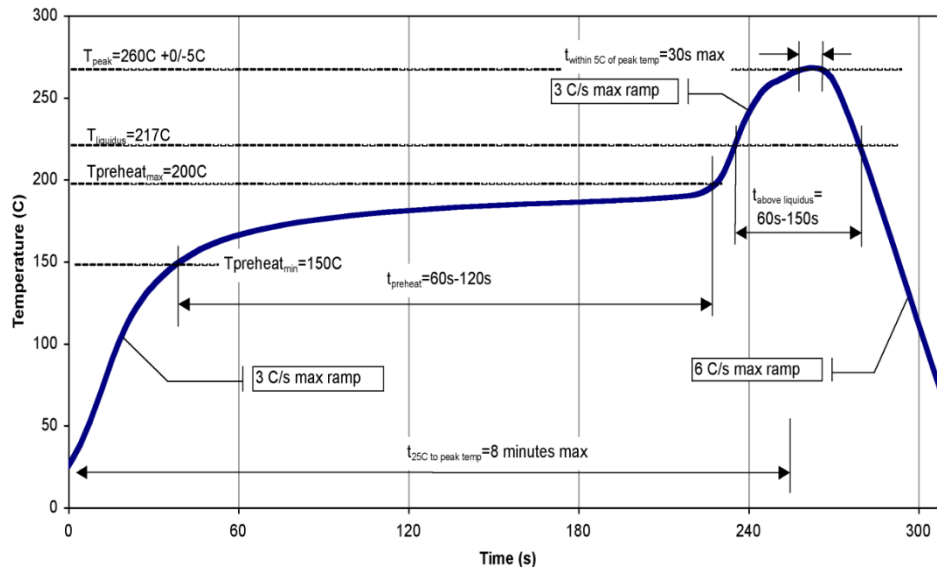

## RoHS Compliance

This product is compliant with the 2011/65/EU RoHS directive (Restrictions on the Use of Certain Hazardous Substances in Electrical and Electronic Equipment), as amended by Directive 2015/863/EU. This product also has the following attributes:

- Lead Free
- Halogen Free (Chlorine, Bromine)
- Antimony Free
- TBBP-A (C<sub>15</sub>H<sub>12</sub>Br<sub>4</sub>O<sub>2</sub>) Free
- PFOS Free
- SVHC Free



## Contact Information

---

For the latest specifications, additional product information, worldwide sales and distribution locations:

Web: [www.qorvo.com](http://www.qorvo.com)

Tel: 1-844-890-8163

Email: [customer.support@qorvo.com](mailto:customer.support@qorvo.com)

## Important Notice

---

The information contained herein is believed to be reliable; however, Qorvo makes no warranties regarding the information contained herein and assumes no responsibility or liability whatsoever for the use of the information contained herein. All information contained herein is subject to change without notice. Customers should obtain and verify the latest relevant information before placing orders for Qorvo products. The information contained herein, or any use of such information does not grant, explicitly or implicitly, to any party any patent rights, licenses, or any other intellectual property rights, whether with regard to such information itself or anything described by such information. **THIS INFORMATION DOES NOT CONSTITUTE A WARRANTY WITH RESPECT TO THE PRODUCTS DESCRIBED HEREIN, AND QORVO HEREBY DISCLAIMS ANY AND ALL WARRANTIES WITH RESPECT TO SUCH PRODUCTS WHETHER EXPRESS OR IMPLIED BY LAW, COURSE OF DEALING, COURSE OF PERFORMANCE, USAGE OF TRADE OR OTHERWISE, INCLUDING THE IMPLIED WARRANTIES OF MERCHANTABILITY AND FITNESS FOR A PARTICULAR PURPOSE.**

Without limiting the generality of the foregoing, Qorvo products are not warranted or authorized for use as critical components in medical, lifesaving, or life-sustaining applications, or other applications where a failure would reasonably be expected to cause severe personal injury or death.

Copyright 2025 © Qorvo, Inc. | Qorvo is a registered trademark of Qorvo, Inc.