

ACT85611EVK1-101 User's Guide

Description

This document describes the characteristics and operation of the Qorvo ACT85611EVK1-101 evaluation kit (EVK). It provides setup and operation instructions, schematic, layout, BOM, and test data. This EVK demonstrates the ACT85611-101T Active PMU power management IC. Other ACT85611Q CMI options can be evaluated on this EVK by replacing the IC and any other necessary components.

Features

The EVK can be used as a standalone board if desired. However, to access the internal registers and to take full advantage of the IC's capability, the user must connect the EVK kit to a PC with Qorvo's USB-TO-I2C interface dongle and use the GUI software. The EVK provides full access to each converter's input and output voltage, as well as all the digital control signals. This gives the user the flexibility to configure the EVK to match their real system.

Note that the ACT85611EVK1-101 is specifically configured for the ACT85611-101T.



Figure 1– EVK Picture

Innovative Power™

ActiveSwitcher™ is a trademark of Qorvo.

## EVK Contents

The ACT85611EVK1-101 evaluation kit comes with the following items:

1. EVK assembly
2. USB-TO-I2C dongle
  - a. Dongle
  - b. Custom 4-pin connector that connects the USB-TO-I2C dongle to the EVK assembly

## Required Equipment

ACT85611EVK1-101

USB-TO-I2C Dongle

Power supply – 12V @ 6A for full power operation

Oscilloscope – >100MHz, >4 channels

Loads – Electronic or resistive. 6.0A minimum current capability.

Digital Multi-meters (DMM)

Windows compatible computer with spare USB port.

## Hardware Setup

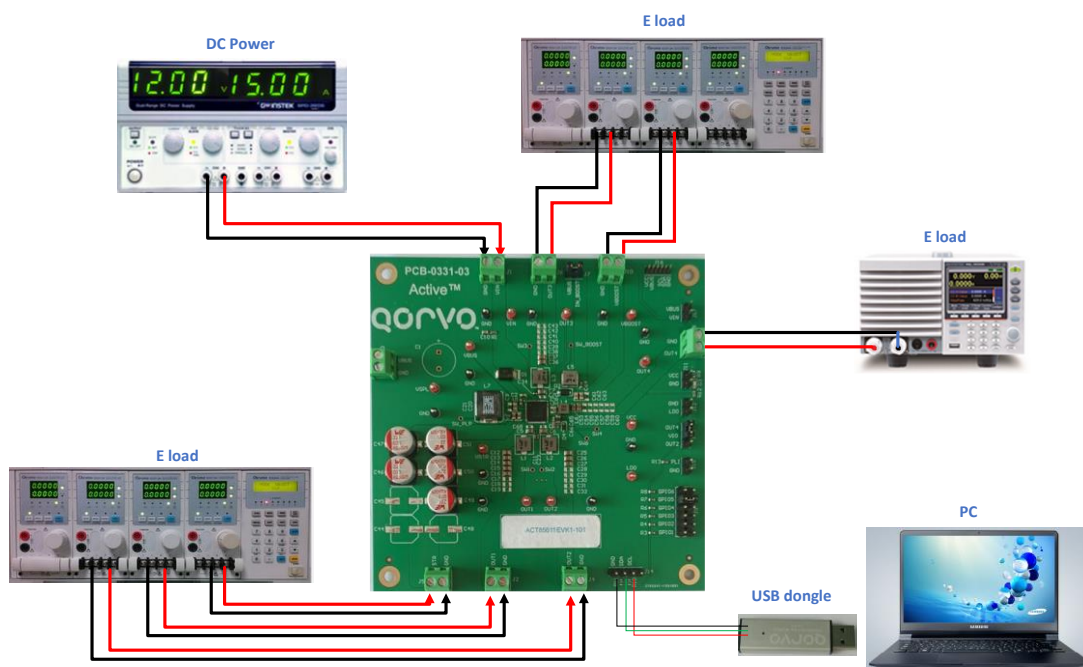

Figure 2 – EVK Setup

Innovative Power™

ActiveSwitcher™ is a trademark of Qorvo.

## Quick Start

### Hardware Setup

1. Decide which voltage will power VIO. Qorvo recommends powering VIO from the OUT4. Install a shorting jumper between J13-2 and J13-3 to power VIO from the OUT4 output voltage. Or connect a shorting jumper between J13-1 and J13-2 to power VIO from the OUT2 output voltage.
2. Connect a lab supply between J1-1 and J1-2 to power VIN.
3. Connect a shorting jumper to J7 to power the Boost input voltages from VBUS.
4. Connect a shorting jumper between J9-3 (GPIO5) and J9-4 (GND). This connection is required for ACT85611-101T.
5. Note that the typical setup is to apply 12V input voltage to all inputs. Using different input voltage sources requires careful consideration of startup sequencing.
6. Turn on the lab supplies.
7. Connect an appropriate load to each power supply output.
8. The outputs turn on automatically when voltage is applied to VIN.

### GUI Setup (optional)

1. Refer to the end of this document for detailed instructions to install the ACT85611 GUI Rev1.5.
2. Connect the USB-TO-I2C dongle to the computer via a USB cable.
3. Connect the USB-TO-I2C dongle to the EVK J14 connector. Refer to Figure 4 to ensure the correct polarity of the connection. As a guide, use the “Qorvo” logo or (“Active-Semi”) logo on the top of the dongle so the black wire is connected to the Dongle GND pin.

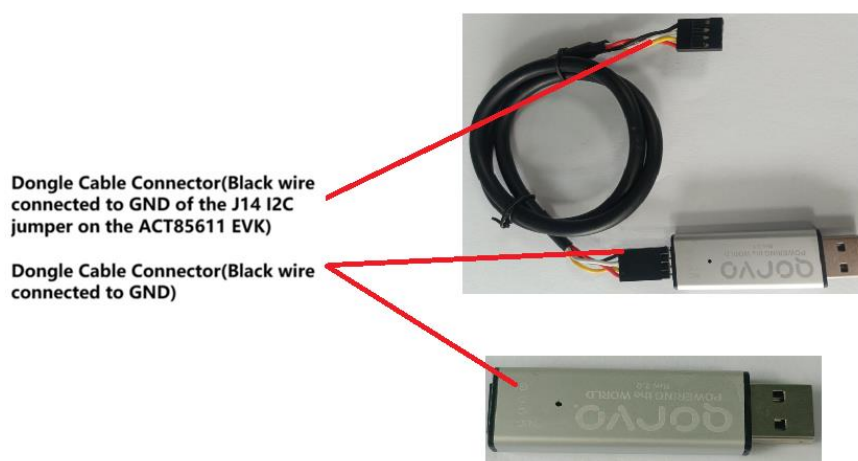

**Figure 3 – USB-TO-I2C Dongle Connection**

Innovative Power™

ActiveSwitcher™ is a trademark of Qorvo.

## EVK Design Parameters

The ACT85611EVK1-101 is designed for a 12V input voltage. The maximum operating voltage is determined by the IC's maximum input voltage rating. The minimum operating voltages are determined by the VIN\_UV. Maximum currents are determined by the IC's CMI settings, which can be changed via I2C after startup. Maximum rated current of boost is dependent on input and output voltages of boost.

**Table 1. EVK Design Parameters**

Parameter	Description	Min	Typ	Max	Unit
VIN	Operation Input range of Power Supply	6	12	13.1	V
Vstr	The storage capacitor voltage		28		V
V <sub>PLP_Buck</sub>	Supplement mode voltage of PLP_Buck		4.3		V
V <sub>LDO</sub>	LDO output voltage		2.5		V
I <sub>B1_max</sub>	Maximum Buck 1 load current		4.0	6.0	A
I <sub>B2_max</sub>	Maximum Buck 2 load current		4.0	6.0	A
I <sub>B3_max</sub>	Maximum Buck 3 load current		4.0	6.0	A
I <sub>B4_max</sub>	Maximum Buck 4 load current		2.0	3.0	A
I <sub>Boost_max</sub>	Maximum Boost load current			1	A
I <sub>VCC_max</sub>	Maximum VCC load current			0.1	A

## EVK Operation

### Turn On

Apply the 12V input voltage. All outputs automatically turn on with the programmed startup sequence.

### Reset NVM/VM of PLP/PMU when from SPLMNT to POR

The ACT85611 has a function of reset all NVM and VM bits for both PLP and PMU parts when IC transfers from supplement mode to POR state.

### Hard RESET

GPIO5 is used for the Hard RESET function. It is defined as an active high input. After the system starts up, drive GPIO5 from low to high to shut down all outputs and put the IC back in the POR state. If the 12V input voltage is still applied, pulling GPIO5 from high to low restarts the system.

### Discharge Function

Discharge function is used to discharge VBUS and STR. It is disabled by default. To enable the Discharge functions, set bit 2 of register 0xEBh to "1" through the GUI. Pull GPIO3 high to activate this function.

## Test Results

**CMI 101  
Startup with Hot Plug**

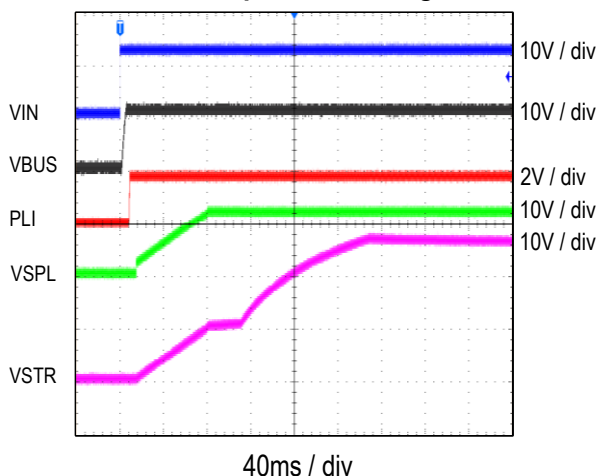

**CMI 101  
STR Charge at Start-up**

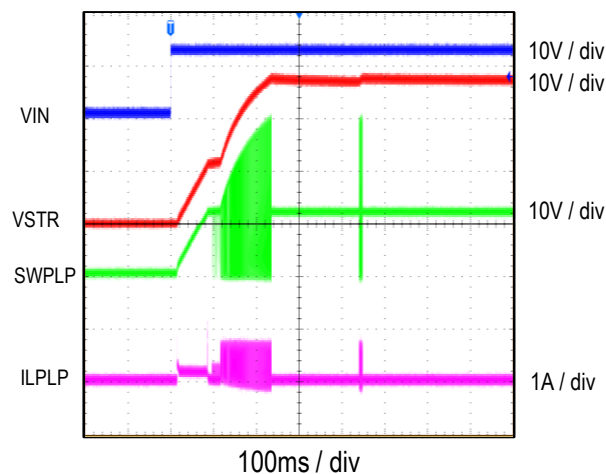

Innovative Power™

ActiveSwitcher™ is a trademark of Qorvo.

**CMI 101**  
Enter Supplement Mode

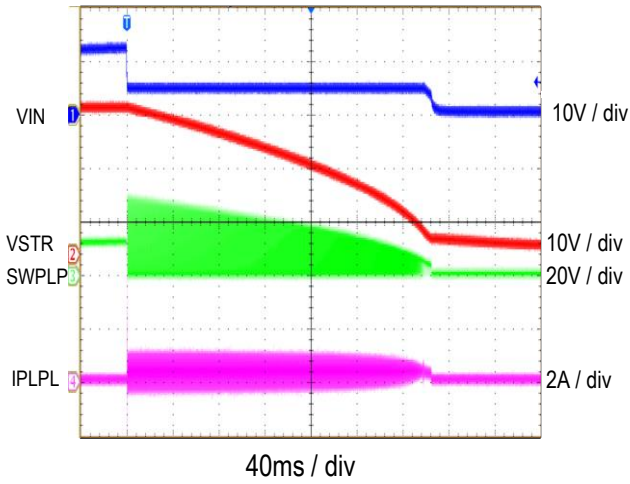

**CMI 101**  
PLP Health Check, STR Cap=1100uF

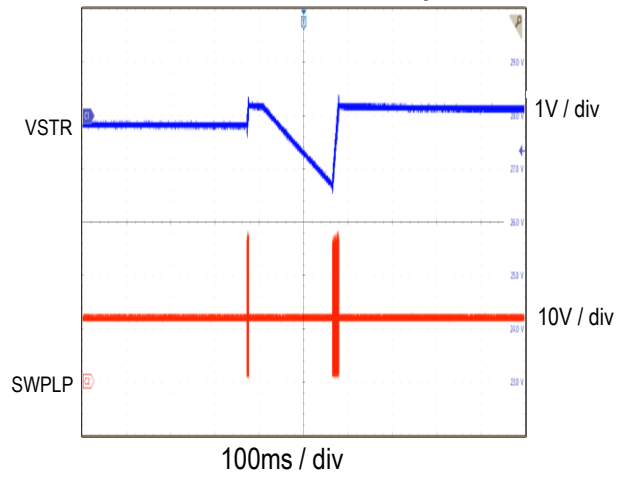

**CMI 101**  
Supplement SW and Ripple, VSTR=28V, I<sub>o</sub>=3A

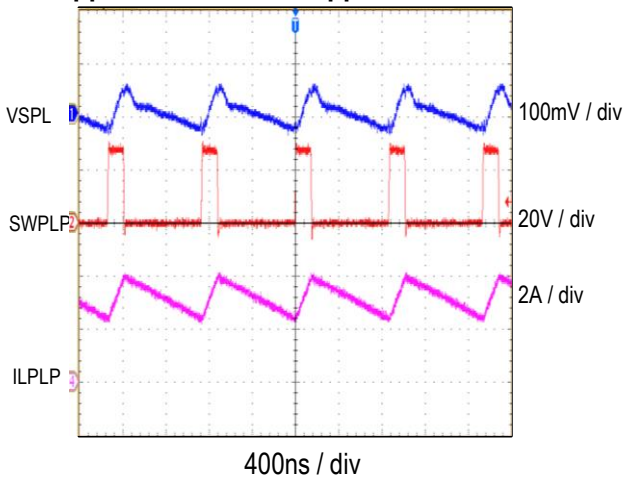

**CMI 101**  
Supplement Load Transient, VSTR=28V, 0.3A-2.7A

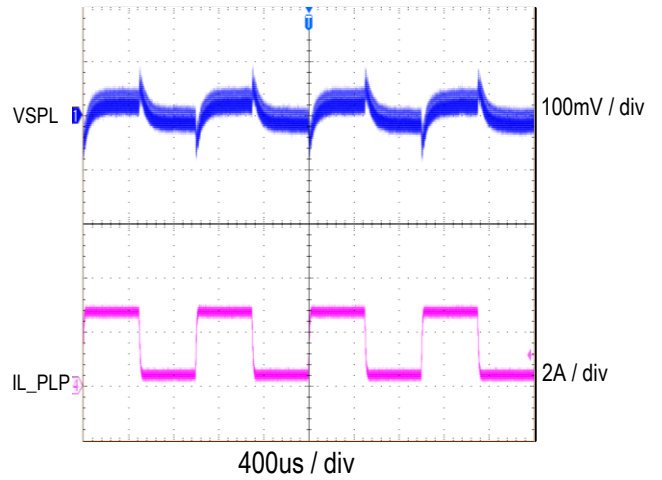

Innovative Power™

ActiveSwitcher™ is a trademark of Qorvo.

**CMI 101  
PMU Start Sequence**

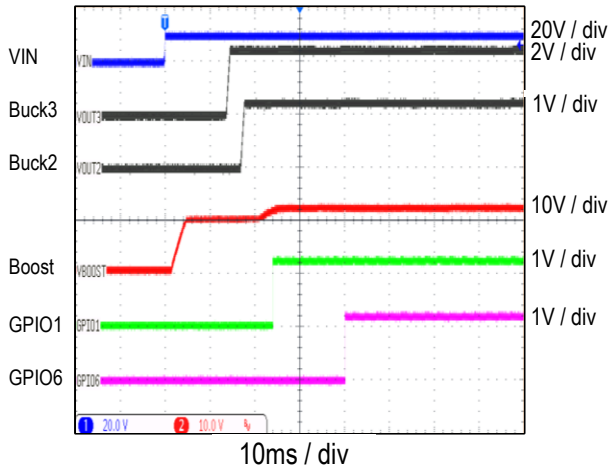

**CMI 101  
PMU Enter Sleep Mode by I2C**

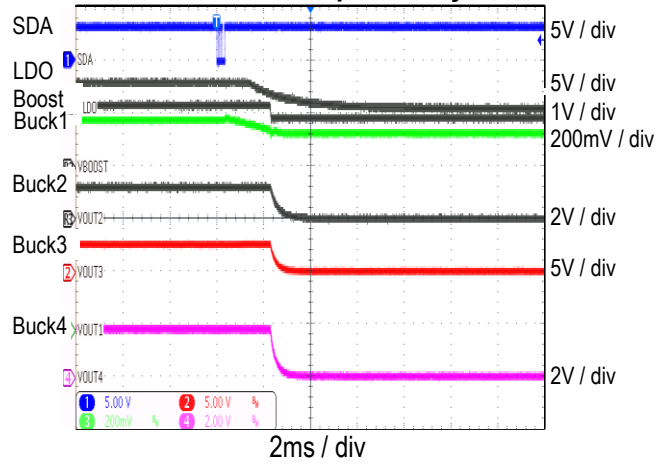

**CMI 101  
Buck1 SW and Ripple @ 3A Load, Buck1=0.8V**

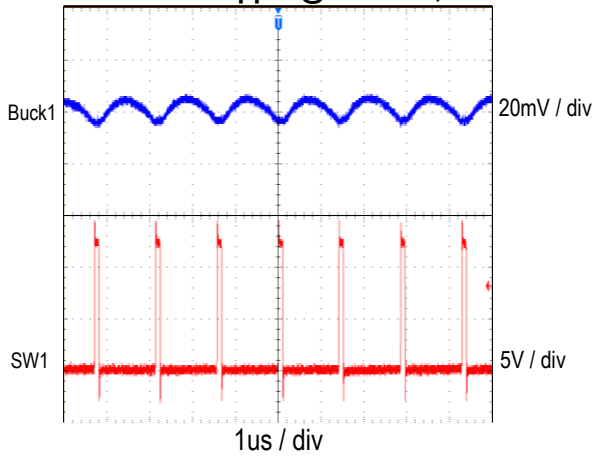

**CMI 101  
Buck4 SW and Ripple @ no load, Buck4=1.8V**

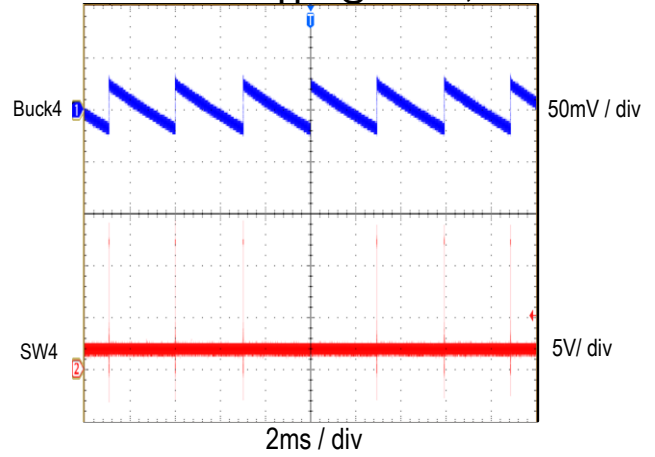

Innovative Power™

ActiveSwitcher™ is a trademark of Qorvo.

**CMI 101**  
**Boost SW and Ripple @ 0.05A load, Boost=12V**

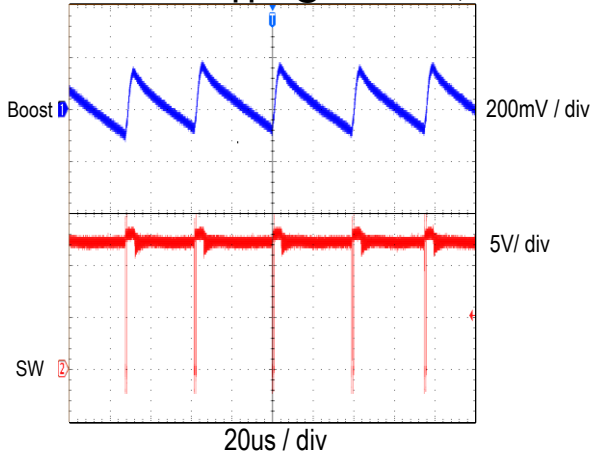

**CMI 101**  
**Buck1 Load Transient, 1.5A-4.5A, Buck1=0.8V**

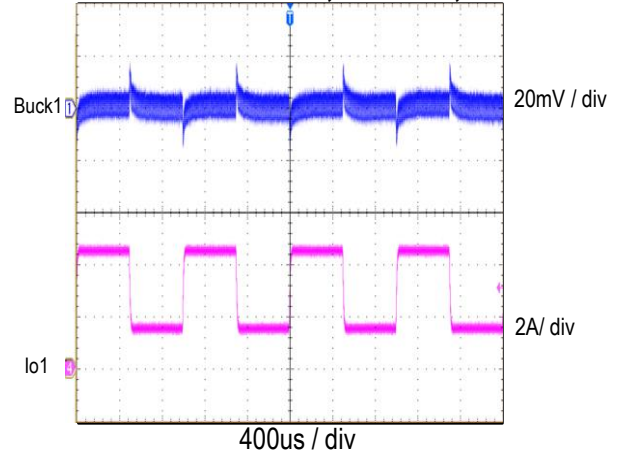

**CMI 101**  
**Buck3 Load Transient, 1.5A-4.5A, Buck3=2.5V**

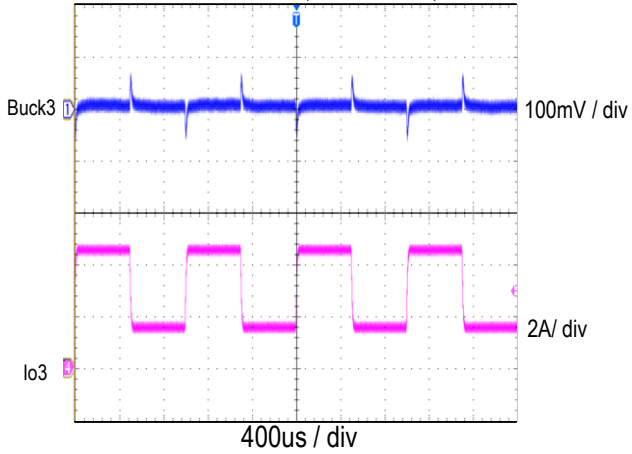

**CMI 101**  
**PMIC/PLP Reset from Supplement**

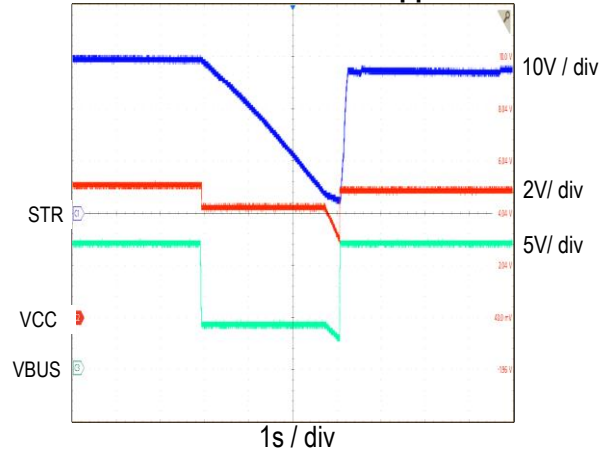

Innovative Power™

ActiveSwitcher™ is a trademark of Qorvo.

## Schematic

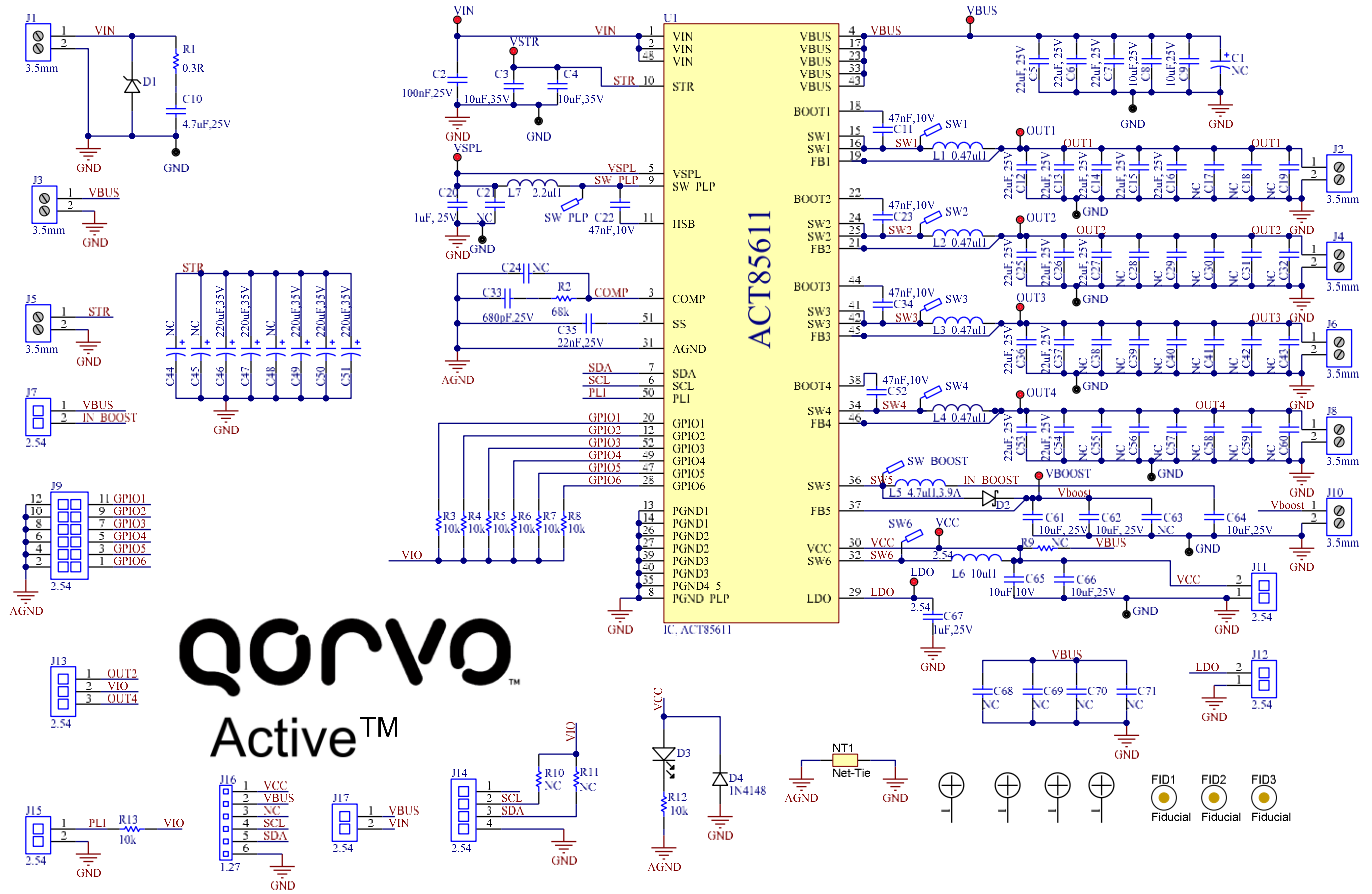

Figure 4 – ACT85611 EVK1-101 Schematic

Innovative Power™

ActiveSwitcher™ is a trademark of Qorvo.

## Layout

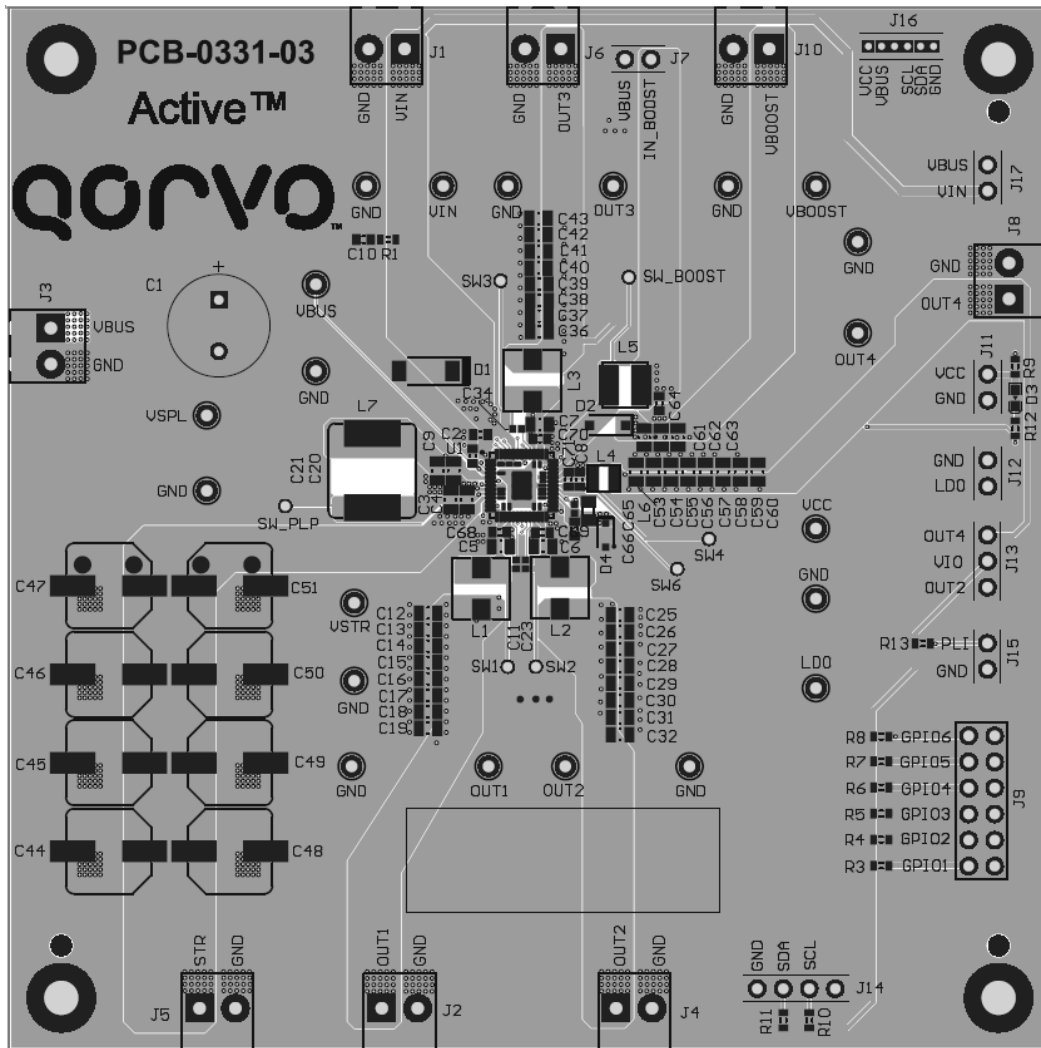

Figure 5 – Layout Top Layer

Innovative Power™

ActiveSwitcher™ is a trademark of Qorvo.

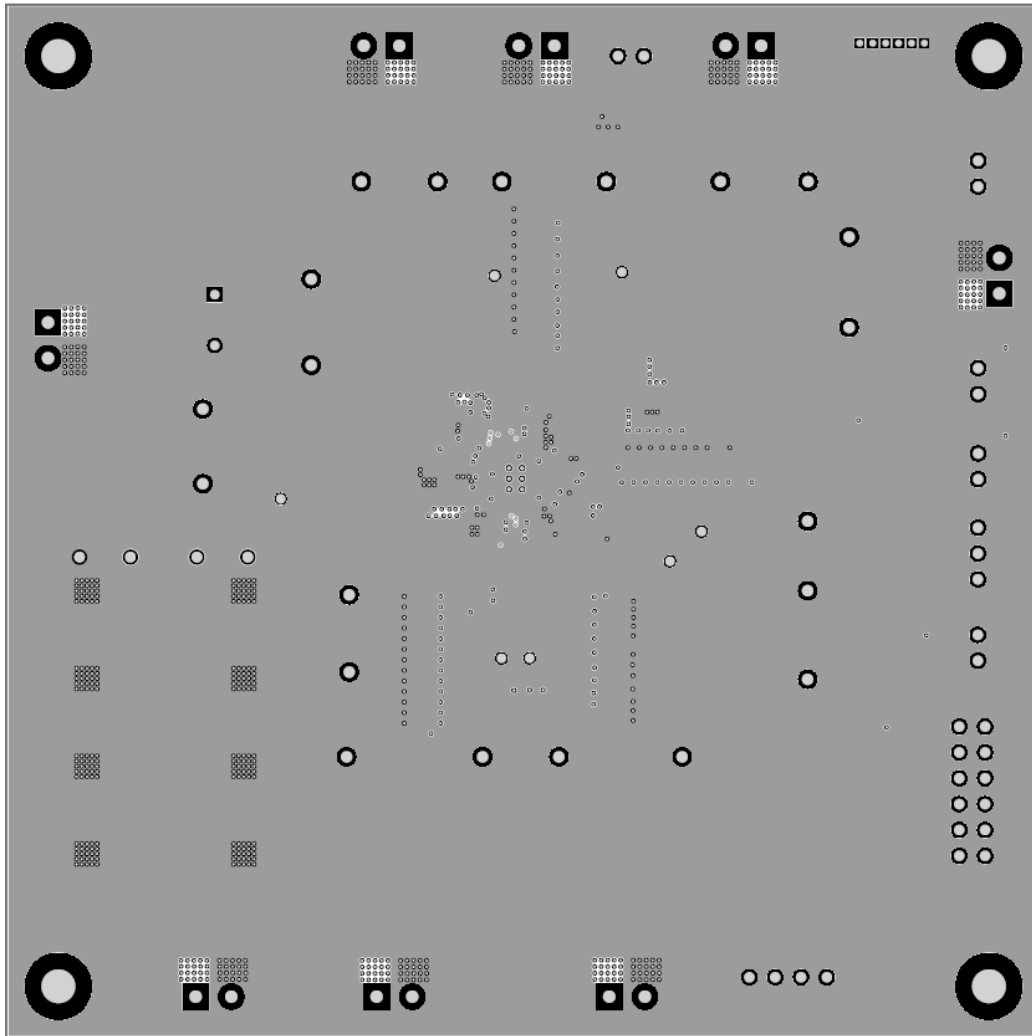

Figure 6 – Layout Layer 2

---

Innovative Power™

ActiveSwitcher™ is a trademark of Qorvo.

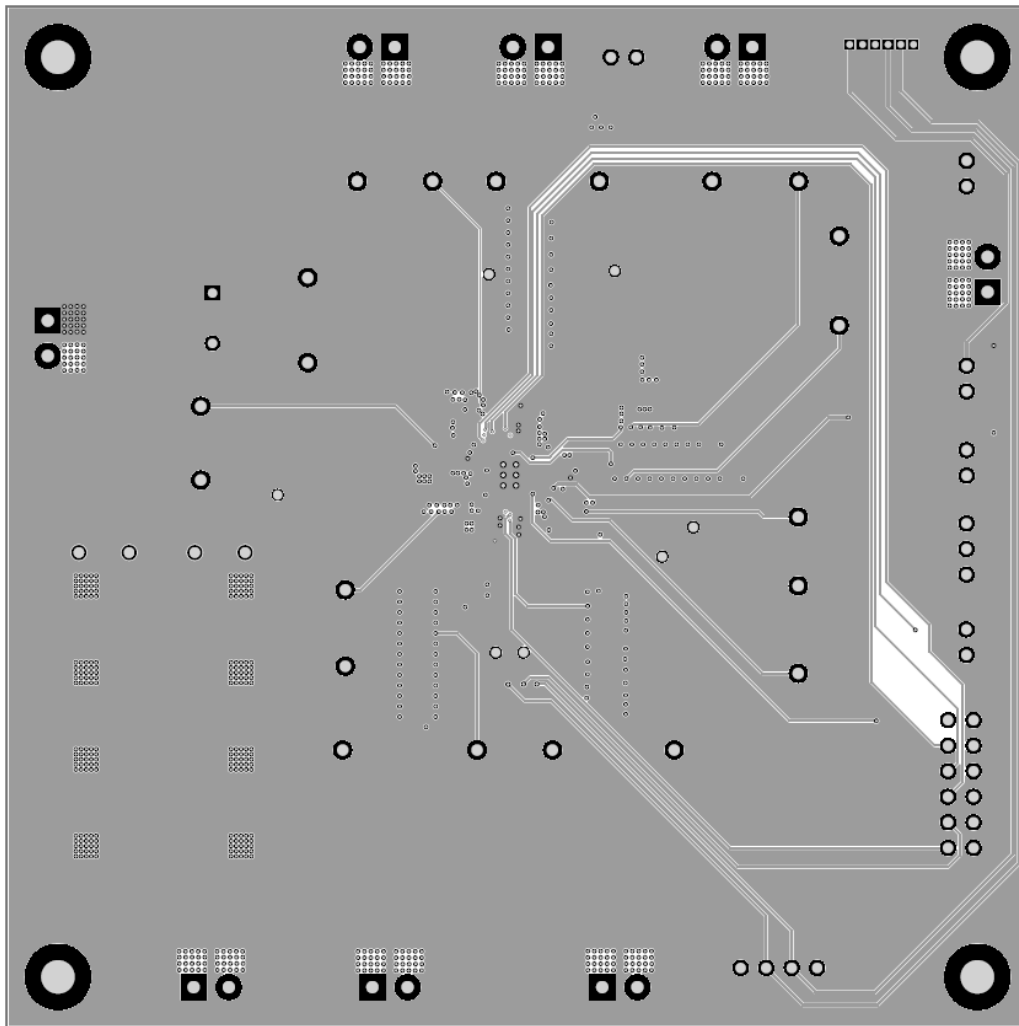

Figure 7 – Layout Layer 3

---

Innovative Power™

ActiveSwitcher™ is a trademark of Qorvo.

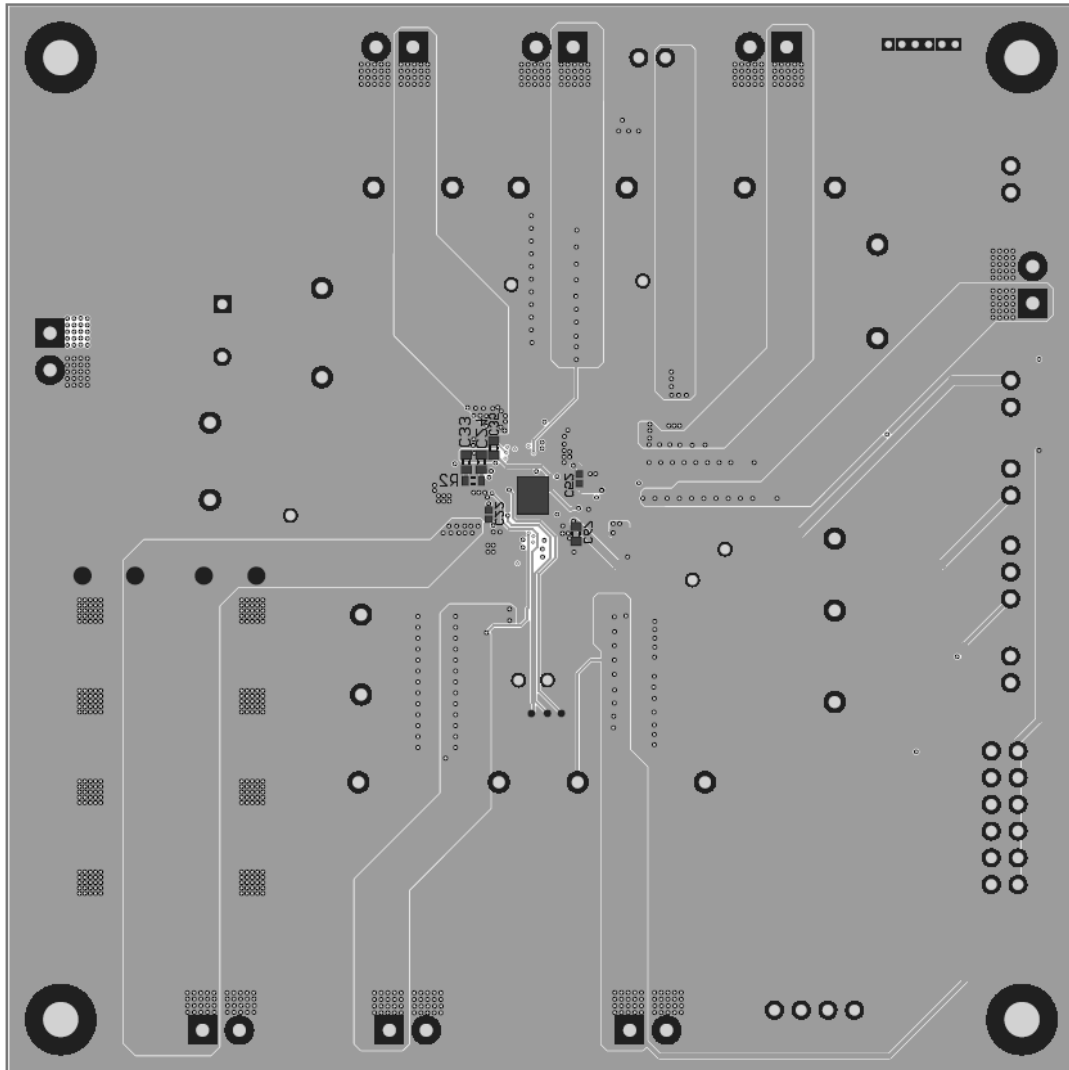

Figure 8 – Layout Bottom Layer

---

Innovative Power™

ActiveSwitcher™ is a trademark of Qorvo.

**Bill of Materials**
**Table 2 – BOM**

Item	Designator	Quantity	Description	Package	Manufacturer	Part Number
1	C1	0	Cap, Aluminium Electrolytic, 220uF, 35V, DNP	6.3*11mm	Würth Elektronik	860010674014
2	C2	1	Cap, Ceramic, 100nF, 35V, 20%, X5R	0603	std	std
3	C3, C4, C61, C62	3	Cap, Ceramic, 10uF, 35V, 20%, X5R	0805	std	std
4	C63	0	Cap, Ceramic, 10uF, 35V, 20%, X5R, DNP	0805	std	std
5	C5, C6, C7, C12, C13, C14, C15, C16, C25, C26, C27, C36, C37, C53, C54	15	Cap, Ceramic, 22uF, 25V, 20%, X5R	0805	std	std
6	C8, C9, C64, C66	4	Cap, Ceramic, 10uF, 25V, 20%, X5R	0603	std	std
7	C10	1	Cap, Ceramic, 4.7uF, 25V, 20%, X5R	0603	std	std
8	C11, C22, C23, C34, C52	5	Cap, Ceramic, 47nF, 10V, 20%, X5R	0402	std	std
9	C17, C18, C19, C28, C29, C30, C31, C32, C38, C39, C40, C41, C42, C43, C55, C56, C57, C58, C59, C60	0	Cap, Ceramic, 22uF, 25V, 20%, X5R, DNP	0805	std	std
10	C20	1	Cap, Ceramic, 1uF, 25V, X5R	0805	std	std
11	C21	0	Cap, Ceramic, 1uF, 25V, X5R, DNP	0805	std	std
12	C24	0	Cap, Ceramic, 1pF, 25V, 20%, X5R, DNP	0603	std	std
13	C33	1	Cap, Ceramic, 680pF, 50V	0603	std	std
14	C35	1	Cap, Ceramic, 22nF, 25V, 20%, X5R	0603	std	std
15	C46, C47, C49, C50, C51	5	Cap, Aluminium Electrolytic, 220uF, 35V	8*10.8mm	Würth Elektronik	865080553014
16	C44, C45, C48	0	Cap, Aluminium Electrolytic, 220uF, 35V, DNP	8*10.8mm	Würth Elektronik	865080553014
17	C65	1	Cap, Ceramic, 10uF, 10V, 20%, X5R	0402	std	std
18	C67	1	Cap, Ceramic, 1uF, 25V, 20%, X5R	0603	std	std
19	C68, C69, C70, C71	0	Cap, Ceramic, 47nF, 25V, 20%, X5R, DNP	0603	std	std
20	D1	1	Power TVS Diode, 15V/24.6A	D0-214AA	Würth Elektronik	824520151
21	D2	1	Diode, Schottky, 40V/3A	SOD123	Nexperia	PMEG40T30ER

Innovative Power™

ActiveSwitcher™ is a trademark of Qorvo.

22	D3	1	LED, Blue	0603	std	std
23	D4	1	Diode, 1N4148, 75V/150mA	SOD323	std	std
24	J1, J2, J3, J4, J5, J6, J8, J10	8	CON, Screw Terminal, 3.50, 2P, KF350		Wurth Elektronik	691214110002
25	J7, J11, J12, J15, J17	5	Header, Unshrouded, 2.54, Male, 2P	CON2	Wurth Elektronik	61300211121
26	J9	1	Header, Unshrouded, 2.54, Male, 6x2P	CON6x2	Wurth Elektronik	61301221121
27	J13	1	Header, Unshrouded, 2.54, Male, 3P	CON3	Wurth Elektronik	61300311121
28	J14	1	Header, Unshrouded, 2.54, Male, 4P	CON4	Wurth Elektronik	61300411121
29	J16	1	Header, Unshrouded, 1.27, Male, 6P	CON6	Digekey	GRPB061VWV N-RC
30	L1, L2, L3	3	Inductor, 1uH	4020	Wurth Elektronik	74438356010
31	L4	1	Inductor, 1uH	3020	Wurth Elektronik	74438336010
32	L5	1	Inductor, 4.7uH, 3.9A	4030	Wurth Elektronik	74438357047
33	L6	1	Inductor, 10uH, 0.7A	0805	Wurth Elektronik	74479777310A
34	L7	1	Inductor, 2.2uH	8070	Wurth Elektronik	7443340220
35	LDO, OUT1, OUT2, OUT3, OUT4, VBOOST, VBUS, VCC, VIN, VSPL, VSTR	11	TEST POINT PC MINI .040"D RED		std	std
36	R1	1	Res, 0.3Ω, 5%	0603	std	std
37	R2	1	Res, 68kΩ, 5%	0603	std	std
38	R3, R4, R5, R6, R7, R8, R12, R13	8	Res, 10kΩ, 5%	0603	std	std
39	R9	0	Res, 0Ω, 5%, DNP	0603	std	std
40	R10, R11	0	Res, 10kΩ, 5%, DNP	0603	std	std
41	TP1, TP2, TP3, TP4, TP5, TP6, TP7, TP8, TP9, TP10	10	TEST POINT PC MINI .040"D BLK		std	std
42	U1	1	IC, ACT85611-101T	QFN52, FCSLP-6x6	Qorvo	ACT85611-101T

Innovative Power™

ActiveSwitcher™ is a trademark of Qorvo.

## GUI Installation

1. You can find the ACT85611 GUI Rev1.5 files on the Qorvo website. Save them on your computer.
2. Plug the USB-TO-I<sup>2</sup>C dongle into a free USB port.
3. Follow the instructions of “Qorvo’s GUI and Dongle Driver Installation” in the “Driver” folder.
4. Double click on the ACT85611 GUI Rev1.5.exe to start the ACT85611 GUI.

Folder	2025/4/29 15:10	文件夹	
CodingMatrix	2025/4/29 15:10	文件夹	
Config	2025/4/29 15:09	文件夹	
Data	2025/4/29 15:10	文件夹	
DieLib	2025/4/29 15:09	文件夹	
Driver	2025/4/29 15:09	文件夹	
Function	2025/4/29 15:10	文件夹	
Script	2025/4/29 15:09	文件夹	
Temp	2025/4/29 15:09	文件夹	
TileLib	2025/4/29 15:09	文件夹	
ACT85611 EVK GUI User Guide Rev1.0	2024/6/25 13:43	Adobe Acrobat Do...	310 KB
ACT85611 GUI Rev1.5	2025/4/29 9:16	应用程序	18,831 KB
Qorvo’s GUI and Dongle Driver Installatio...	2023/2/3 10:59	Adobe Acrobat Do...	1,178 KB

Figure 9 – GUI Folder

## Dongle Connection Status

The GUI also contains a dongle connected status which indicates that Active-Semi’s USB-TO-I<sup>2</sup>C dongle is connected to the USB port of the driver installed. The figure below shows the two possible indication status graphics.

### Dongle



Figure 10– Dongle Connection Status

## GUI Operating Functions

The GUI has 4 basic function buttons allocated in top-left of the Tool Bar which are open, save, read and Write I<sup>2</sup>C.

### Open Function

The Open function opens ACT85611’s register information data (.iact) or (.cmi) files from the computer. The file should be either provided by Qorvo or saved by the same software previously. This loads the file’s register settings into the GUI. Note that this does not load the register settings into the ACT85611.

Innovative Power™

ActiveSwitcher™ is a trademark of Qorvo.

### Save Function

The Save function saves the GUI's register information to a (.iact) file on the computer. Note that this does not save the ACT85611 register settings into the file. Qorvo recommends saving the IC's original register settings to a (.iact) file before implementing any adjustments.

### Read Function

The Read function reads all the IC's register values and shows them in the GUI. Qorvo recommends clicking the "Read" button after powering up an EVK to ensure that the IC's settings are properly transferred into and displayed properly in the GUI. Qorvo also recommends performing a "Read" function immediately after a "Write" function to ensure that the data was properly written to the IC.

### Write Function

The Write function transfers all the GUI settings to the IC. Note that any changes to the GUI settings are not transferred into the IC until the "Write" button is clicked. Note that data written to the IC using the "Write" function is volatile. The IC's register settings change back to their default settings when power is cycled.

### Configuration Mode

The GUI contains 2 setting modes: The GUI starts up in the Configuration mode screen and displays each regulator's basic information on single page. The user can use either the mouse scroll or the right-side scroll bar to navigate to other regulators. This display mode allows users to change some basic settings of each regulator (voltages, current, timing). Using drop-boxes, left-click the small arrow next to the value, then a selection pop-up displays all possible options to choose from. Scroll up/down to find the target value and left-click to select it. After the required parameters are changed, click the "Write" button to transfer the changes from the GUI to the IC.

The following figure 11 shows an example where the user clicked the drop-box arrow to select a different Buck1 VSET0 output voltage.

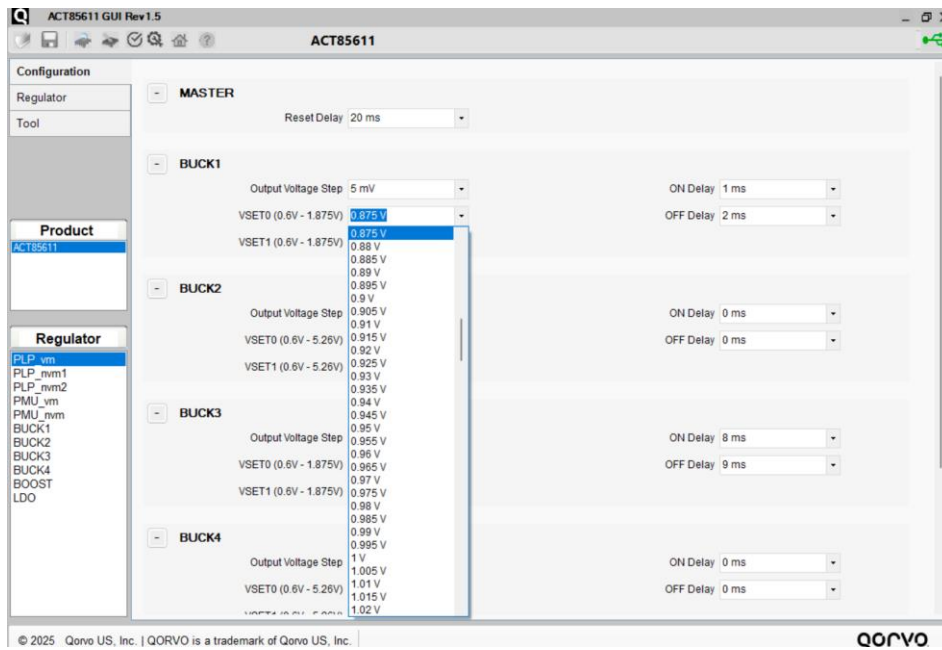

Figure 11 – Change Configuration items

### Individual Regulator Mode

The GUI allows the user to view and change the IC’s advanced internal registers of each regulator. This is accomplished in the “Individual Regulator Mode” tab. Navigate to this mode by left clicking on the Regulator tab button, then select the target regulator from the Regulator list. The GUI gives the user two options for changing the regulator settings: The “Settings” tab and the “Register” tab. Figure 12 below shows these two options.

The “Settings” tab is easy to read and has drop down menus that show the available choices. The Registers” tab shows the actual register values required to achieve a desired setting. This tab is useful for debugging customer firmware. To change the setting in the “Register” tab, simply click the “bit name” button to flip the bit value between “0” and “1” as shown in Figure 13.

Note: Remember that changes to the GUI settings are not transferred into the IC until the GUI’s “Write” button is pressed.

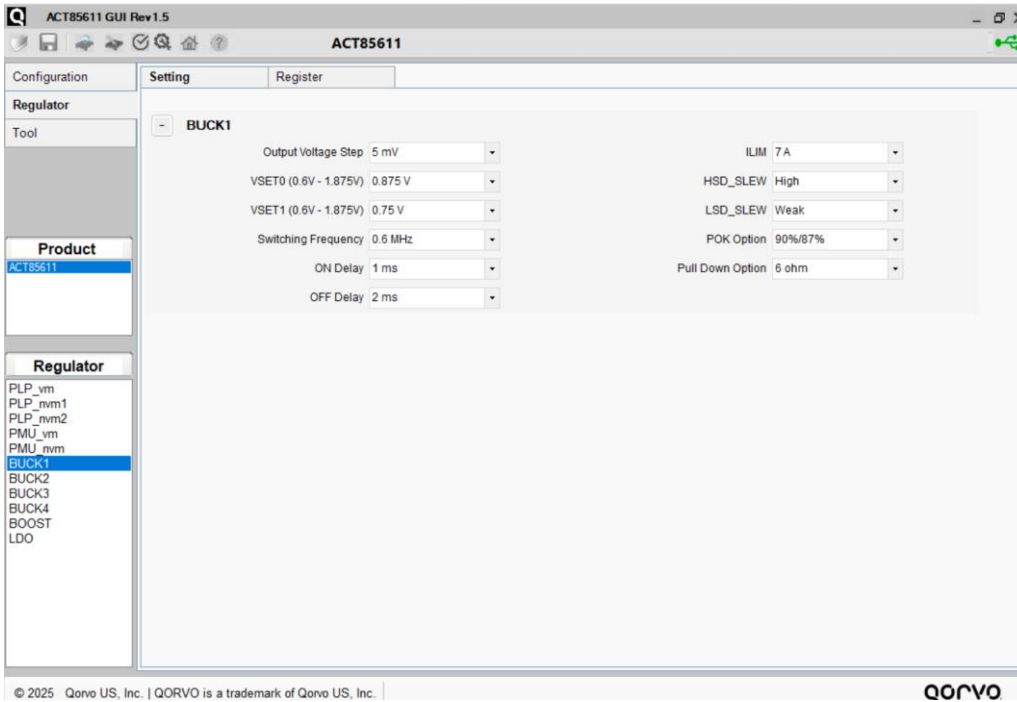

Figure 12 – Regulator mode with Settings

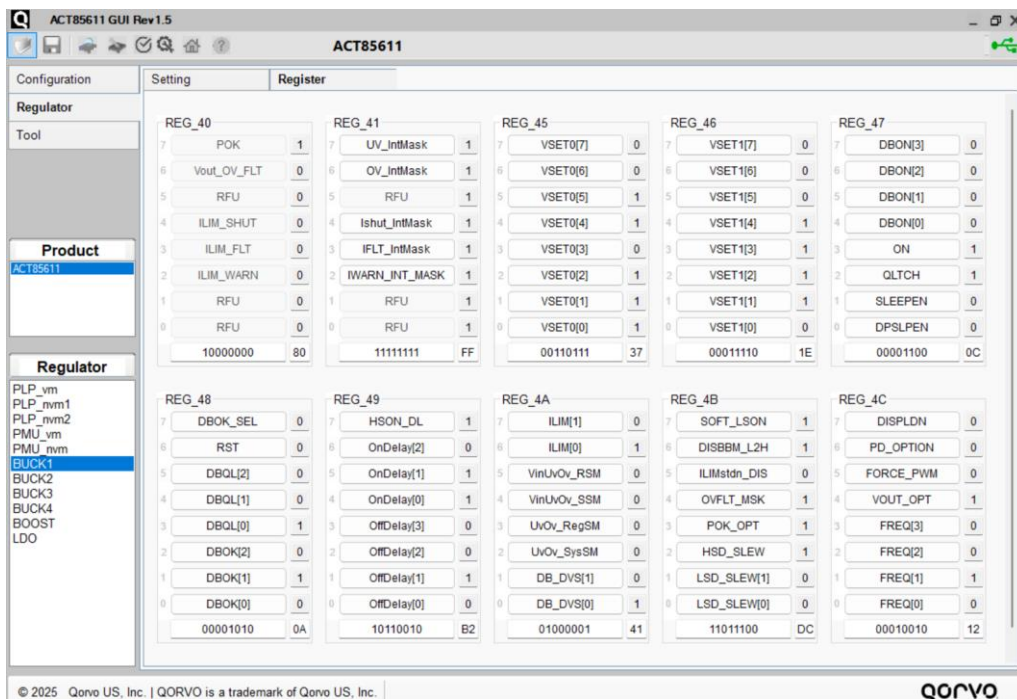

Figure 13 – Regulator mode with Register

## Storage Cap Read

Storage Capacitance Read ACT85611 also has the feature of reading out the storage capacitance. In top off mode storage cap is boosted up to VSTR\_SET and keep the STR output pin at this voltage. HCHK\_NG is always 0 at this phase. Then ACT85611 uses a 10mA current sink to discharge the storage cap from VSTR\_SET to HMON\_THR - 1V. Internal discharging timer only starts at HMON\_THR. Based on the discharge time, ACT85611 can calculate the capacitance on the STR output pin and store this value in the CAP\_VALUE [12:0] register. This register information and 13-bit information can be read from address 0xE0h [7:3] and 0xE4h [7:0].

The maximum capacitance that can be read is 8.191mF because of the limitation of the 13 register bits assigned for reading this value. Any larger capacitance will return in 0x1FFF.

## Process of Health Checking & Capacitance Read

1. Make sure you have good I2C connection with IC with correct I2C address. Please note that the PLP and PMIC have two different I2C addresses.
2. Choose proper HMON\_TSET[3:0] and HMON\_THR[3:0] values.
3. If want single shot operation, set DIS\_HEALTH\_CHK = 1.
4. Set FORCE\_HCHK = 1 to start health checking and capacitance read.
5. Wait for HMON\_TSET plus proper time for health check.
6. Capacitance read timer from HMON\_THR to HMON\_THR-1V.
7. Read the capacitance on CAP\_VALUE [12:0].