



QM47655

5-7.2 GHz 802.11be Wi-Fi FEM

Product Overview

The QM47655 is a WLAN 5.0-7.2 GHz FEM consisting of a 5-7.2 GHz multi-mode PA die with coupler and an LNA + Switch die.

The QM47655 is an 802.11be front-end module in an ultra-small footprint. The front-end module supports multiple TX bias modes. The architecture and interface are optimized for next generation WLAN integration into handsets, tablets, and other hand-held and portable devices.

The front-end module features chipset-specific compatible control voltages to facilitate ease of use. With its low power dissipation, the front-end module die kit contributes to the extended battery life of next generation WLAN solutions.

Functional Block Diagram

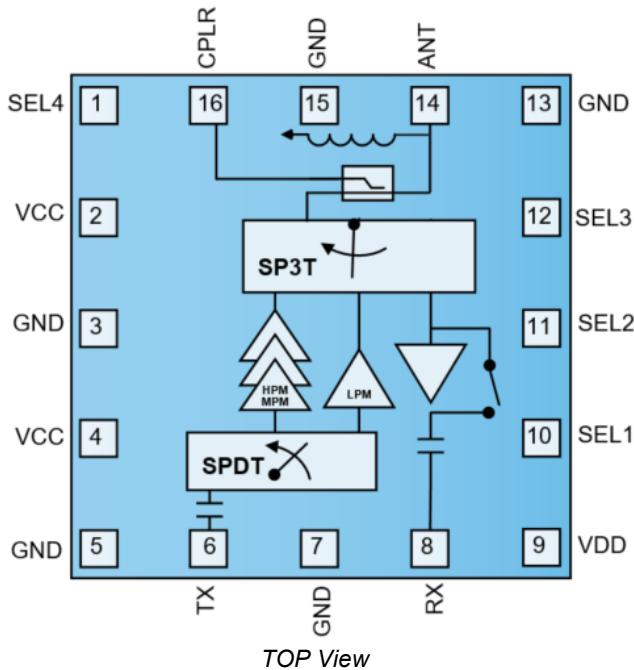

Key Features

- Fully Integrated, high performance 802.11be front-end module with true 320 MHz Channels and 4096-QAM.
- Extended operating frequency range up to 7.2 GHz
- Temperature Compensated Bias Network
- High Performance Power Amplifier
- Multiple TX Bias Modes
- Single direct battery voltage
- LNA with High Gain, Low Current, and Bypass Modes
- Antenna T/R Switch
- Integrated Power Coupler

Applications

- IEEE 802.11n/a/ac/ax/be WLAN Applications.
- Dual-band Wireless LAN Systems
- Portable Battery-Powered Equipment

Ordering Information

Part Number	Description
QM47655TR13	13" reel with 10000 pieces
QM47655EVB	Fully assembled evaluation board
QM47655SR	7" reel with 100 pieces
QM47655SB	5 piece sample bag

Absolute Maximum Ratings

PARAMETER	CONDITIONS	RATING
Storage Temperature		-40 to 150 °C
Maximum Junction Temperature, T _j max		170 °C
Device Voltage, V _{cc}		+6.0 V
RF Maximum Input Power (Tx Mode)	802.11n MCS0, 50Ω, V _{cc} = 5.0 V, T = 25°C	+ 12 dBm
RF Maximum Input Power (Rx Mode)	802.11n MCS0, 50Ω, V _{cc} = 5.0 V, T = 25°C	+ 25 dBm
RF Maximum Input Power (Bypass Mode)	802.11n MCS0, 50Ω, V _{cc} = 5.0 V, T = 25°C	+ 25 dBm
Ruggedness Condition: RF Maximum Input Power (Tx Mode)	802.11n MCS0, 10:1 VSWR, V _{cc} = 5.0 V, T = 25°C, 85°C	+ 5 dBm

Operation of this device outside the parameter ranges given above may cause permanent damage.

Recommended Operating Conditions

Parameter	Conditions	Min.	Typ.	Max.	Units
Operating Temperature		-40	25	85	°C
Operating Voltage V _{cc}	V _{phone}	3.0	3.85	5.0	V
Operating Voltage V _{dd}		1.65	1.8	1.95	V
RF Impedance	All RF ports (single-ended)	-	50	-	Ohms
Control Voltage (V-high)	SEL1 / SEL2 / SEL3 / SEL4	1.6	1.8	1.9	V
Control Voltage (V-low)	SEL1 / SEL2 / SEL3 / SEL4	0	0.1	0.4	V
Control Current (I-high)	SEL1 / SEL2 / SEL3 / SEL4	-	4	-	uA
Control Current (I-low)	SEL1 / SEL2 / SEL3 / SEL4	-	-	1	uA
High Isolation (Sleep) Current	SEL1 / SEL2 / SEL3/ SEL4= LOW	-	12	-	uA
Bypass Current	SEL1 / SEL2 = HIGH, SEL3 = LOW	-	15	-	uA

Electrical specifications are measured at nominal operating conditions. Unless noted otherwise.

Logic Truth Table

Operating Mode	Test Mode Name	SEL1	SEL2	SEL3	SEL4
Transmit High	TXH	1	0	0	x
Transmit High Efficiency	TXHE	0	1	1	x
Transmit Middle-High	TXMH	1	1	0	x
Transmit Middle	TXM	1	0	1	x
Transmit Middle-Low	TXML	0	0	1	x
Transmit Low	TXL	1	1	1	0
Receive High	RXH	0	1	0	0
Receive Low	RXL	0	0	0	1
RX Bypass	BYP	0	1	0	1
Bluetooth High	BTH	1	1	0	x
Bluetooth Low	BTL	1	1	1	1
High Isolation	ISO	0	0	0	0

CONFIDENTIAL: NDA REQUIRED

Electrical Specifications – 5 – 7.2GHz Transmit, High Power Mode
 (V_{CC}=3.85V; Temp=25°C; EVM is DPD enabled; unless noted otherwise)

PARAMETER	CONDITIONS	MIN.	TYP.	MAX.	UNITS
Frequency Range		5150	-	7115	MHz
Small Signal Gain		-	31	-	dB
Gain Flatness	For any 80/160 MHz bandwidth For 802.11ac/ax signals over freq. range		+/- 0.4		dB
Gain Flatness	For entire frequency band		+/- 2.0		dB
Margin to Spectrum Emission Mask 802.11a, 6 Mbps	Pout = 22.0 dBm	3	5	-	dB
Margin to Spectrum Emission Mask 802.11ax, MCS0, 20MHz	Pout = 21.0 dBm	3	5	-	dB
DEVM 802.11n, MCS7, HT20/40	Pout = 19 dBm	-	-43	-	dB
DEVM 802.11ac MCS9, HE80	Pout = 17.5 dBm	-	-42	-	dB
DEVM 802.11ax, MCS11, HE160	Pout = 16.5 dBm	-	-41	-	dB
DEVM 802.11be, MCS13, HE320	Pout = 13.5 dBm	-	-42	-	dB
DC Current 802.11a, 6 Mbps	Pout = 22 dBm	-	220	-	mA
DC Current 802.11n, MCS7, HT20	Pout = 19 dBm	-	180	-	mA
DC Current 802.11ac, MCS9, HE80	Pout = 17.5 dBm	-	170	-	mA
DC Current 802.11ax, MCS11, HE160	Pout = 16.5 dBm	-	165	-	mA
DC Current 802.11be, MCS13, HE320	Pout = 13.5 dBm	-	155	-	mA
Quiescent Current	No RF Applied	-	145	-	mA
Harmonics (2f ₀), 802.11a	Pout = 22.0 dBm; 6 Mbps	-	-34	-	dBm/MHz
Harmonics (3f ₀), 802.11a	Pout = 22.0 dBm; 6 Mbps	-	-52	-	dBm/MHz
PA Settling Time		-	215	-	nS
Return Loss – TX Port		-	24	-	dB
Return Loss – ANT Port		-	12	-	dB
PA Stability	Pout = 22.0 dBm; VSWR 4:1 all phases. V _{CC} = 3.85 V	All non-harmonically related spurs < -41.25 dBm/MHz			

Operation condition is +25C degrees at 3.85V unless otherwise noted.

Electrical Specifications – 5 – 7.2GHz Transmit, High Efficiency Mode
(V_{CC}=3.85V; Temp=25°C; EVM is DPD enabled; unless noted otherwise)

PARAMETER	CONDITIONS	MIN.	TYP.	MAX.	UNITS
Frequency Range		5150	-	7115	MHz
Small Signal Gain		-	30	-	dB
Gain Flatness	For any 80/160 MHz bandwidth For 802.11ac/ax signals over freq. range	-	+/-0.3	-	dB
Gain Flatness	For entire frequency band	-	+/-1	-	dB
Margin to Spectrum Emission Mask 802.11a, 6 Mbps	Pout = 19.0 dBm	3	5	-	dB
Margin to Spectrum Emission Mask 802.11ax, MCS0, 20MHz	Pout = 18.0 dBm	3	5	-	dB
DEVM 802.11n, MCS7, HT20/40	Pout = 16.5 dBm	-	-44	-	dB
DEVM 802.11ac, MCS9, HE80	Pout = 14.5 dBm	-	-43	-	dB
DEVM 802.11ax, MCS11, HE160	Pout = 13.5 dBm	-	-42	-	dB
DC Current 802.11a, 6 Mbps	Pout = 19.0 dBm	-	235	-	mA
DC Current 802.11n, MCS7, HT20/40	Pout = 16.5 dBm	-	135	-	mA
DC Current 802.11ac, MCS9, HE80	Pout = 14.5 dBm	-	125	-	mA
DC Current 802.11ax, MCS11, HE160	Pout = 13.5 dBm	-	120	-	mA
Quiescent Current	No RF Applied	-	100	-	mA
Harmonics (2f ₀), 802.11a	Pout = 19.0 dBm; 6 Mbps	-	-35	-	dBm/MHz
Harmonics (3f ₀), 802.11a	Pout = 19.0 dBm; 6 Mbps	-	-56	-	dBm/MHz
PA Settling Time		-	220	-	nS
Return Loss – TX Port		-	24.5	-	dB
Return Loss – ANT Port		-	10	-	dB
PA Stability	Pout = 19.0 dBm; VSWR 4:1 all phases. V _{CC} = 3.85 V	All non-harmonically related spurs < -41.25 dBm/MHz			

Operation condition is +25C degrees at 3.85V unless otherwise noted.

Electrical Specifications – 5 – 7.2GHz Transmit, Middle High Power Mode
(V_{CC}=3.85V; Temp=25°C; EVM is DPD enabled; unless noted otherwise)

Parameter	Conditions	Min.	Typ.	Max.	Units
Frequency Range		5150	-	7115	MHz
Small Signal Gain		-	24.5	-	dB
Gain Flatness	For any 80/160 MHz bandwidth For 802.11ac/ax signals over freq. range	-	+/-0.3	-	dB
Gain Flatness	For entire frequency band	-	+/-1	-	dB
Margin to Spectrum Emission Mask 802.11a, 6 Mbps	Pout = 16.0 dBm	3	5	-	dB
Margin to Spectrum Emission Mask 802.11ax, MCS0, 20MHz	Pout = 15.0 dBm	3	5	-	dB
DEVM 802.11n, MCS7, HE20/40	Pout = 13.0 dBm	-	-43	-	dB
DEVM 802.11ac, MCS9, HE20/40	Pout = 12.0 dBm	-	-42	-	dB
DEVM 802.11ax, MCS11, HE20/40	Pout = 11.5 dBm	-	-43	-	dB
DEVM 802.11be, MCS13, HE20/40	Pout = 10.5 dBm	-	-45	-	dB
DC Current 802.11n, MCS7, HT20/40	Pout = 13.0 dBm	-	115	-	mA
DC Current 802.11ac, MCS9, HE20/40	Pout = 12.0 dBm	-	110	-	mA
DC Current 802.11ax, MCS11, HE20/40	Pout = 11.5 dBm	-	105	-	mA
DC Current 802.11be, MCS13, HE20/40	Pout = 10.5 dBm	-	105	-	mA
Quiescent Current	No RF Applied	-	95	-	mA
Harmonics (2f ₀), 802.11a	Pout = 16.0 dBm; 6 Mbps	-	-39	-	dBm/MHz
Harmonics (3f ₀), 802.11a	Pout = 16.0 dBm; 6 Mbps	-	-60	-	dBm/MHz
PA Settling Time		-	200	-	nS
Return Loss – TX Port		-	18	-	dB
Return Loss – ANT Port		-	10	-	dB
PA Stability	Pout = 16.0 dBm; VSWR 4:1 all phases. V _{CC} = 3.85 V	All non-harmonically related spurs < -41.25 dBm/MHz			

Electrical Specifications – 5.0 – 7.2GHz Transmit, Middle Power Mode
(V_{CC}=3.85V; Temp=25°C; EVM is DPD enabled; unless noted otherwise)

PARAMETER	CONDITIONS	MIN.	TYP.	MAX.	UNITS
Frequency Range		5150	-	7115	MHz
Small Signal Gain		-	23	-	dB
Gain Flatness	For any 80/160 MHz bandwidth For 802.11ac/ax signals over freq. range	-	+/-0.2	-	dB
Gain Flatness	For entire frequency band	-	+/-1	-	dB
Margin to Spectrum Emission Mask 802.11a, 6 Mbps	Pout = 13.0 dBm	3	5	-	dB
Margin to Spectrum Emission Mask 802.11ax, MCS0, 20MHz	Pout = 12.0 dBm	3	5	-	dB
DEVM 802.11n, MCS7, HE20/40	Pout = 10.0 dBm	-	-46	-	dB
DEVM 802.11ac, MCS9, HE80	Pout = 8.5 dBm	-	-45	-	dB
DEVM 802.11ax, MCS11, HE160	Pout = 7.5 dBm	-	-44	-	dB
DEVM 802.11be, MCS13, HE320	Pout = 5.0 dBm	-	-45	-	dB
DC Current 802.11a, 6Mbps	Pout = 13.0 dBm	-	75	-	mA
DC Current 802.11n, MCS7, HT20/40	Pout = 10.0 dBm	-	65	-	mA
DC Current 802.11ac, MCS9, HE80	Pout = 8.5 dBm	-	65	-	mA
DC Current 802.11ax, MCS11, HE160	Pout = 7.5 dBm	-	65	-	mA
DC Current 802.11be, MCS13, HE320	Pout = 5.0 dBm	-	65	-	mA
Quiescent Current	No RF Applied	-	65	-	mA
Harmonics (2f ₀), 802.11a	Pout = 13.0 dBm; 6 Mbps	-	-29	-	dBm/MHz
Harmonics (3f ₀), 802.11a	Pout = 13.0 dBm; 6 Mbps	-	-55	-	dBm/MHz
PA Settling Time		-	245	-	nS
Return Loss – TX Port		-	6	-	dB
Return Loss – ANT Port		-	10	-	dB
PA Stability	Pout = 13.0 dBm; VSWR 4:1 all phases. V _{CC} = 3.85 V	All non-harmonically related spurs < -41.25 dBm/MHz			

Operation condition is +25C degrees at 3.85V unless otherwise noted.

Electrical Specifications – 5.0 – 7.2GHz Transmit, Middle Low Power Mode
(V_{CC}=3.85V; Temp=25°C; EVM is DPD enabled; unless noted otherwise)

PARAMETER	CONDITIONS	MIN.	TYP.	MAX.	UNITS
Frequency Range		5150	-	7115	MHz
Small Signal Gain		-	23	-	dB
Gain Flatness	For any 80/160 MHz bandwidth For 802.11ac/ax signals over freq. range	-	+/-0.2	-	dB
Gain Flatness	For entire frequency band	-	+/-1	-	dB
Margin to Spectrum Emission Mask 802.11a, 6 Mbps	Pout = 10.0 dBm	3	5	-	dB
Margin to Spectrum Emission Mask 802.11ax, MCS0, 20MHz	Pout = 9.0 dBm	3	5	-	dB
DEVM 802.11n, MCS7, HE20/40	Pout = 7.0 dBm	-	-45	-	dB
DEVM 802.11ac, MCS9, HE80	Pout = 6.0 dBm	-	-44.5	-	dB
DEVM 802.11ax, MCS11, HE160	Pout = 5.5 dBm	-	-43	-	dB
DEVM 802.11be, MCS13, HE320	Pout = 4.5 dBm	-	-45	-	dB
DC Current 802.11a, 6Mbps	Pout = 10.0 dBm	-	75	-	mA
DC Current 802.11n, MCS7, HT20/40	Pout = 7.0 dBm	-	55	-	mA
DC Current 802.11ac, MCS9, HE80	Pout = 6.0 dBm	-	50	-	mA
DC Current 802.11ax, MCS11, HE160	Pout = 5.5 dBm	-	50	-	mA
DC Current 802.11be, MCS13, HE320	Pout = 4.5 dBm	-	50	-	mA
Quiescent Current	No RF Applied	-	50	-	mA
Harmonics (2f ₀), 802.11a	Pout = 10.0 dBm; 6 Mbps	-	-32	-	dBm/MHz
Harmonics (3f ₀), 802.11a	Pout = 10.0 dBm; 6 Mbps	-	-60	-	dBm/MHz
PA Settling Time		-	270	-	nS
Return Loss – TX Port		-	6	-	dB
Return Loss – ANT Port		-	9	-	dB
PA Stability	Pout = 10.0 dBm; VSWR 4:1 all phases. V _{CC} = 3.85 V	All non-harmonically related spurs < -41.25 dBm/MHz			

Operation condition is +25C degrees at 3.85V unless otherwise noted.

Electrical Specifications – 5 – 7.2GHz Transmit, Low Power Mode
(V_{CC}=3.85V; Temp=25°C; EVM is DPD disabled; unless noted otherwise)

PARAMETER	CONDITIONS	MIN.	TYP.	MAX.	UNITS
Frequency Range		5150	-	7115	MHz
Small Signal Gain		-	16	-	dB
Gain Flatness	For any 80/160 MHz bandwidth For 802.11ac/ax signals over freq. range		+/-0.1		dB
Gain Flatness	For entire frequency band		+/-1.2		dB
Margin to Spectrum Emission Mask 802.11a, 6 Mbps	Pout = 7.0 dBm	3	5	-	dB
Margin to Spectrum Emission Mask 802.11ax, MCS0, 20MHz	Pout = 6.0 dBm	3	5	-	dB
DEVM 802.11n, MCS7, HT20/40	Pout = 4.0 dBm	-	-50	-	dB
DEVM 802.11ac MCS9, HE80	Pout = 2.5 dB,	-	-50	-	dB
DEVM 802.11ax, MCS11, HE160	Pout = 1.5 dBm	-	-50	-	dB
DEVM 802.11be, MCS13, HE320	Pout = -1.5 dBm	-	-47	-	dB
DC Current 802.11a, 6 Mbps	Pout = 7.0 dBm	-	45	-	mA
DC Current 802.11n, MCS7, HE20/40	Pout = 4.0 dBm	-	42	-	mA
DC Current 80.11ac, MCS9, HE80	Pout = 2.5 dBm	-	42	-	mA
DC Current 802.11ax, MCS11, HE160	Pout = 1.5 dBm	-	42	-	mA
DC Current 802.11be, MCS13, HE320	Pout = -1.5 dBm	-	41	-	mA
Quiescent Current	No RF Applied	-	40	-	mA
Harmonics (2f ₀), 802.11a	Pout = 7.0 dBm; 6 Mbps	-	-34	-	dBm/MHz
Harmonics (3f ₀), 802.11a	Pout = 7.0 dBm; 6 Mbps	-	-63	-	dBm/MHz
PA Settling Time		-	220	-	nS
Return Loss – TX Port		-	12	-	dB
Return Loss – ANT Port		-	8	-	dB
PA Stability	Pout = 7.0 dBm; VSWR 4:1 all phases. V _{CC} = 3.85 V	All non-harmonically related spurs < -41.25 dBm/MHz			

Operation condition is +25C degrees at 3.85V unless otherwise noted.

Electrical Specifications – 5.0-7.2 GHz Receive, High Gain at High Current Mode (V_{CC}=3.85V; Temp=25°C; unless noted otherwise)

Parameter	Conditions	Min.	Typ.	Max.	Units
Frequency Range		5150	-	7115	MHz
Gain	LNA High Gain at RXH Mode	-	14.5	-	dB
Gain Flatness	For any 320 MHz bandwidth For 802.11ac/ax/be signals over Freq. range	-	+/-0.3	-	dB
Noise Figure	LNA High Gain at RXH Mode	-	2.5	-	dB
DC Current	LNA High Gain at RXH Mode	-	11	-	mA
Input 1dB compression	LNA High Gain at RXH Mode	-	-11	-	dBm
Input IP2	LNA High Gain at RXH Mode (Out-band)	-	31.5	-	dBm
Input IP3	LNA High Gain Mode (In-Band)	-	1	-	dBm
LNA Settling Time		-	220	-	nS
Return Loss – RX Port		-	11	-	dB
Return Loss – ANT Port		-	5	-	dB

Operating condition is +25degC at 3.85V unless otherwise noted.

Electrical Specifications – 5.0-7.2 GHz Receive, High Gain at Low Current Mode (V_{CC}=3.85V; Temp=25°C; unless noted otherwise)

Parameter	Conditions	Min.	Typ.	Max.	Units
Frequency Range		5150	-	7115	MHz
Gain	LNA High Gain Low Current at RXL Mode	-	11.5	-	dB
Gain Flatness	For any 320 MHz bandwidth For 802.11ac/ax/be signals over Freq. range	-	+/-0.3	-	dB
Noise Figure	LNA High Gain Low Current at RXL Mode	-	2.8	-	dB
DC Current	LNA High Gain Low Current at RXL Mode	-	4	-	mA
Input 1dB compression	LNA High Gain Low Current at RXL Mode	-	-8	-	dBm
Input IP3	LNA High Gain Low Current at RXL Mode (In-Band)	-	2.5	-	dBm
LNA Settling Time		-	295	-	nS
Return Loss – RX Port		-	8.5	-	dB
Return Loss – ANT Port		-	4	-	dB

Operating condition is +25degC at 3.85V unless otherwise noted.

Electrical Specifications – 5.0-7.2 GHz Rx Bypass (V_{CC}=3.85V; Temp=25°C; unless noted otherwise)

PARAMETER	CONDITIONS	MIN.	TYP.	MAX	UNITS
Frequency Range		5150	-	7115	MHz
Gain	LNA Bypass Mode	-4.5	-2.8	-1.5	dB
Gain Flatness	For any 320 MHz bandwidth For 802.11ac/ax/be signals over Freq. range	-	+/-0.1	-	dB
DC Current	LNA Bypass Mode	-	22	24	μA
Input IP2	LNA Bypass Mode (Out-band)	-	31.5	32	dBm
Input IP3	LNA Bypass Mode (In-Band)	-	4.9	6.7	dBm
Return Loss – RX Port		-	9	8	dB
Return Loss – ANT Port		-	8	6	dB

Operating condition is +25degC at 3.85V unless otherwise noted.

Electrical Specifications - Coupler

PARAMETER	CONDITIONS		MIN.	TYP.	MAX.	UNITS
Coupling Factor (CF)	Transmit, High Power Mode	Low	-	23.1	-	dB
		Mid	-	22.2	-	dB
		High	-	22.5	-	dB
	Transmit, High Efficiency Mode	Low	-	23.1	-	dB
		Mid	-	22.1	-	dB
		High	-	22	-	dB
	Transmit, Middle High Power Mode	Low	-	23.1	-	dB
		Mid	-	22.2	-	dB
		High	-	22.5	-	dB
	Transmit, Middle Power Mode	Low	-	24	-	dB
		Mid	-	22.6	-	dB
		High	-	22.4	-	dB
	Transmit, Middle Low Power Mode	Low	-	24	-	dB
		Mid	-	22.6	-	dB
		High	-	22.3	-	dB
Transmit, Low Power Mode	Low	-	24	-	dB	
	Mid	-	22.7	-	dB	
	High	-	22.4	-	dB	
Directivity	VSWR 3:1 check					dB

Operating condition is +25degC at 3.85V unless otherwise noted.

CONFIDENTIAL: NDA REQUIRED

Application Circuit Schematic, Bill of Material

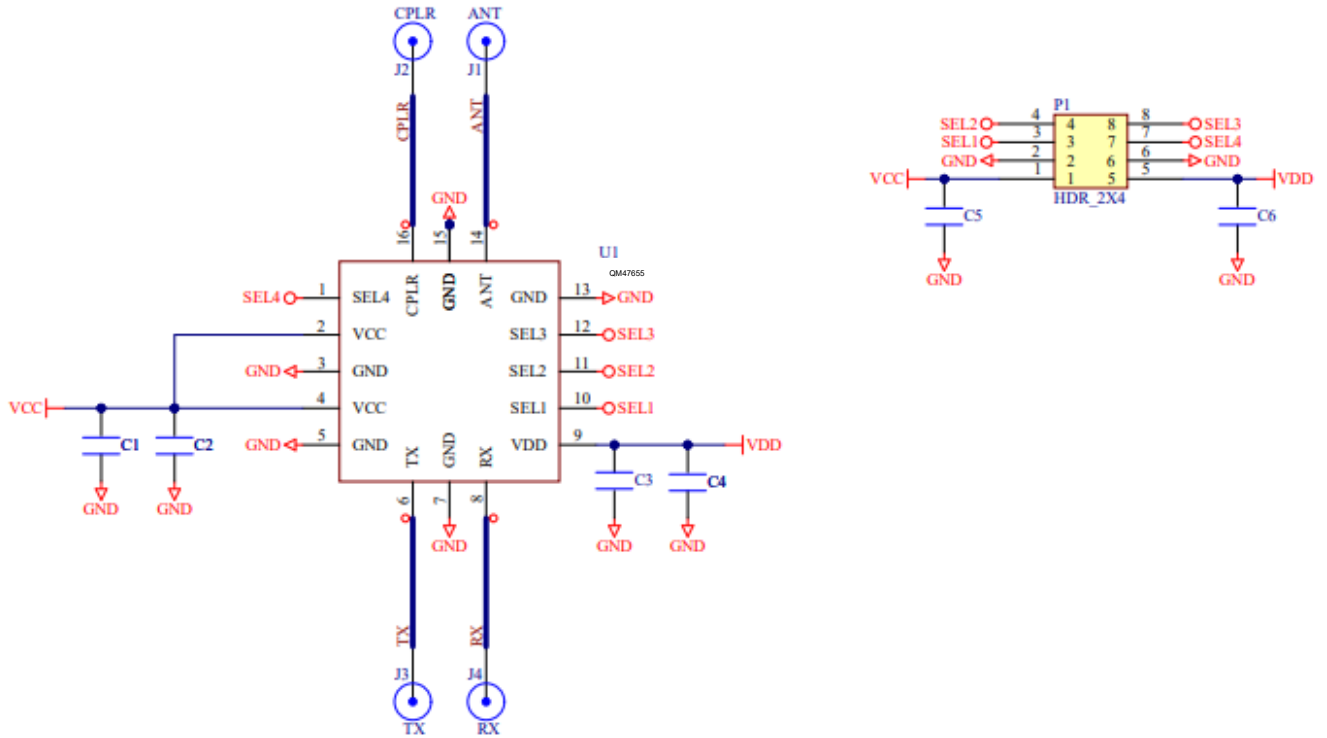

REF. DES.	DESCRIPTION	MANUF.	PART NUMBER
U1	802.11BE WIFI-7 5 – 7.2GHz SINGLE FEM	Qorvo	QM47655
C13, C6	CAP, 4.7uF, 10%, 16V, X5R, 0603	TDK SINGAPORE (PTE) LTD	C1608X5R1C475K080AC
C4, C8	CAP, 1uF, 20%, 10V, X5R, 0201W SCRND	Kyocera Asia Pacific Pte. Ltd.	CM03X5R105M10AH
C3, C7	CAP, 1000pF, 10%, 16V, X7R, 0201	MURATA ELECTRONICS SINGAPORE PTE LT	GRM033R71C102KA01J
R1	IND,2.7nH,+/-0.2nH,1.3A,M/L, MID-Q, 0201	TDK SINGAPORE (PTE) LTD	MLG0603PPA2N7CT000
J1, J2, J3, J4	CONNECTOR, SMA EL FLT VIPER MAT-21-1038	AMPHENOL --- KAI JACK(SHENZHEN) INC	901-10425
P1	CONN, HDR, 2X4, RT-ANG, 0.100", T/H	SAMTEC INC.	TSW-104-08-L-D-RA
C1,C2,C5,C9,C10,C11,C12	NOT POPULATED ITEM	N/A	N/A

RF Evaluation Board – Top and Bottom

Top Layer:

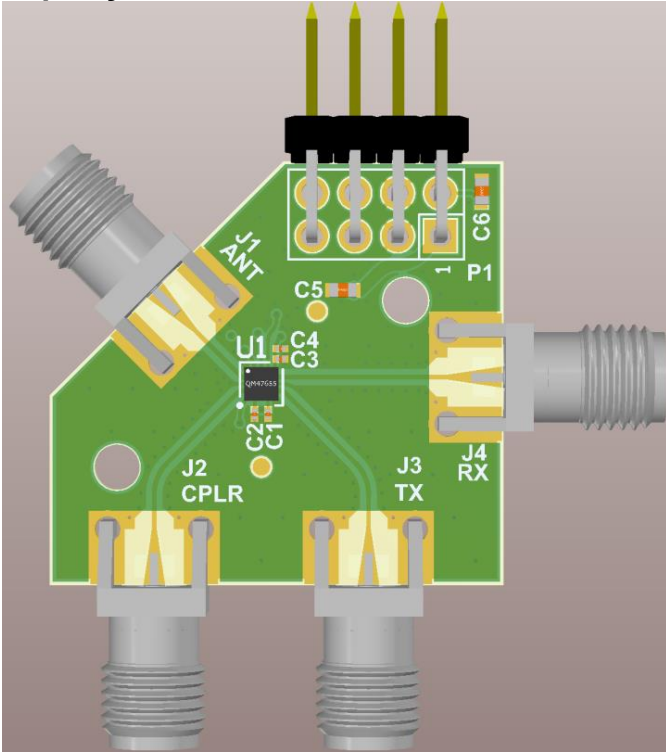

Bottom Layer:

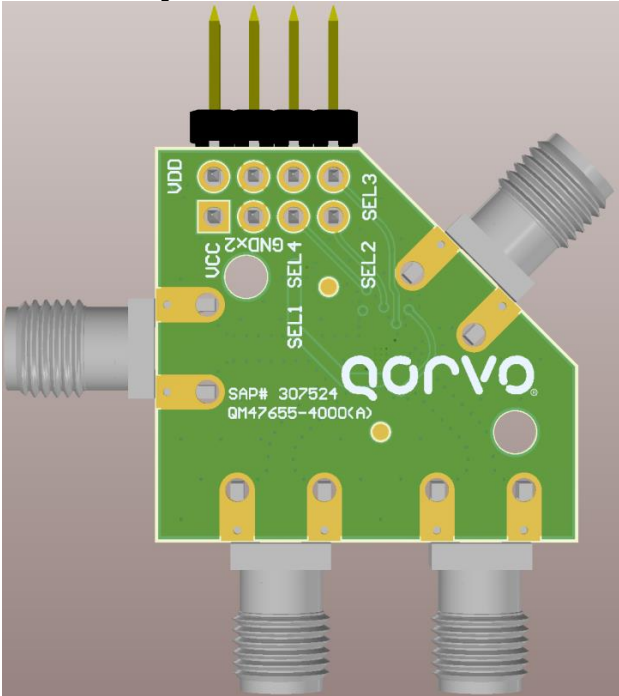

CONFIDENTIAL: NDA REQUIRED

Pin Configuration and Description

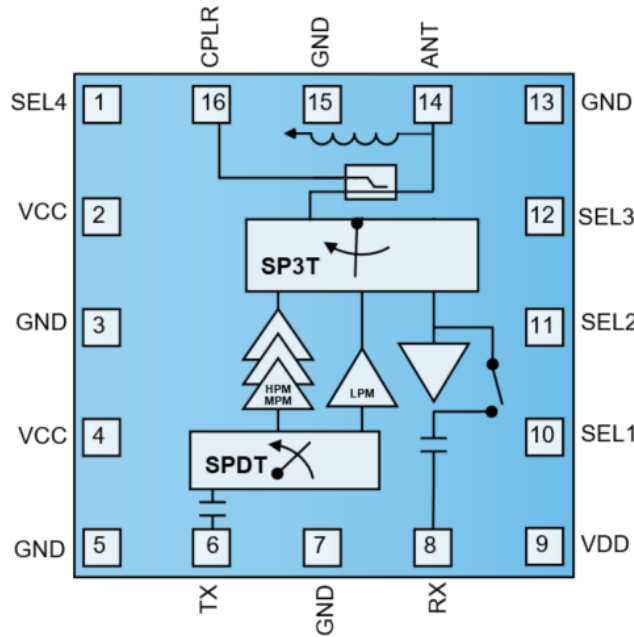

Pin No.	Label	Description
1	SEL4	Control voltage for Receive Low and Isolation modes. See truth table for proper settings.
2, 4	VCC	Supply voltage for PA, switches, regulators. See applications schematic for biasing and bypassing components.
6	TX	RF PA input port matched to 50Ω and DC blocked internally.
8	RX	RF LNA output port. This port is matched to 50Ω and DC blocked internally.
9	VDD	1.8V supply voltage for LNA. See applications schematic for biasing and bypassing components.
10	SEL1	Control voltage for PA modes. See truth table for proper settings.
11	SEL2	Control voltage for LNA and Bypass. See truth table for proper settings.
12	SEL3	Control voltage for PA modes. See truth table for proper settings.
14	ANT	RF bidirectional antenna port matched to 50Ω and DC short internally.
16	CPLR	TX RF coupler output port.
3, 5, 7, 13, 15, 17	GND	Ground connection. The backside of the package should be connected to the ground plane through a short path, i.e., PCB vias under the device are recommended.

Timing Diagram

RF/DC Power ON/OFF Sequence

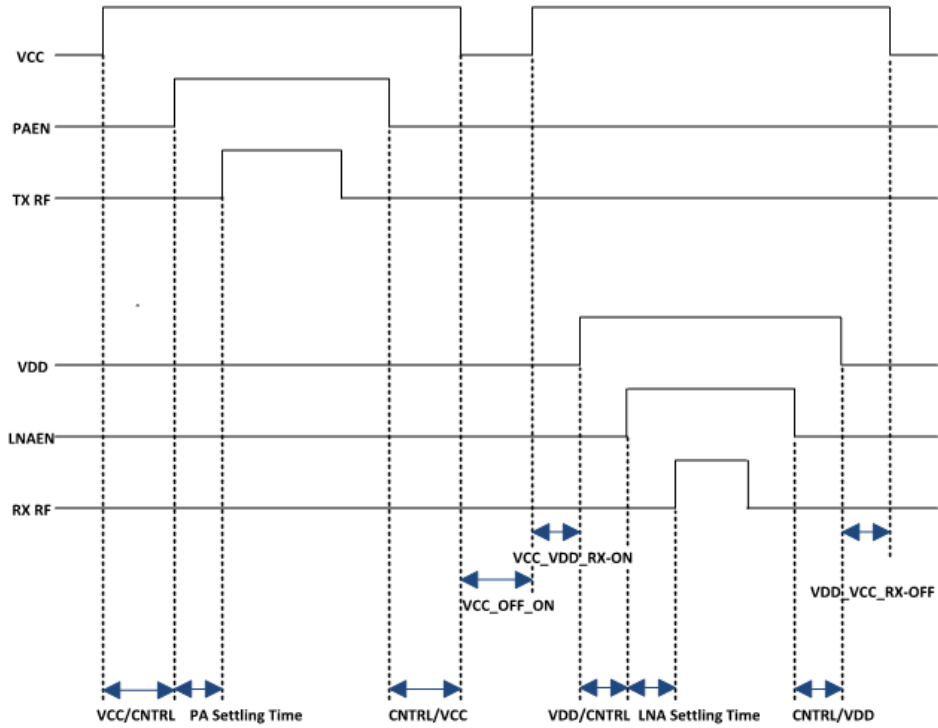

Note:

Observe the timing sequence shown in the diagram above and described below.

- Apply VCC and VDD prior to turning on or pulsing TX CNTL/RX CNTL
- Turn off TX CNTL/RX CNTL prior to turning off VCC and VDD
- Turn on TX CNTL/RX CNTL prior to applying RF signal
- Turn off RF signal prior to turning off TX CNTL/RX CNTL
- TX/RX simultaneous transition is allowed

Package Outline Drawing

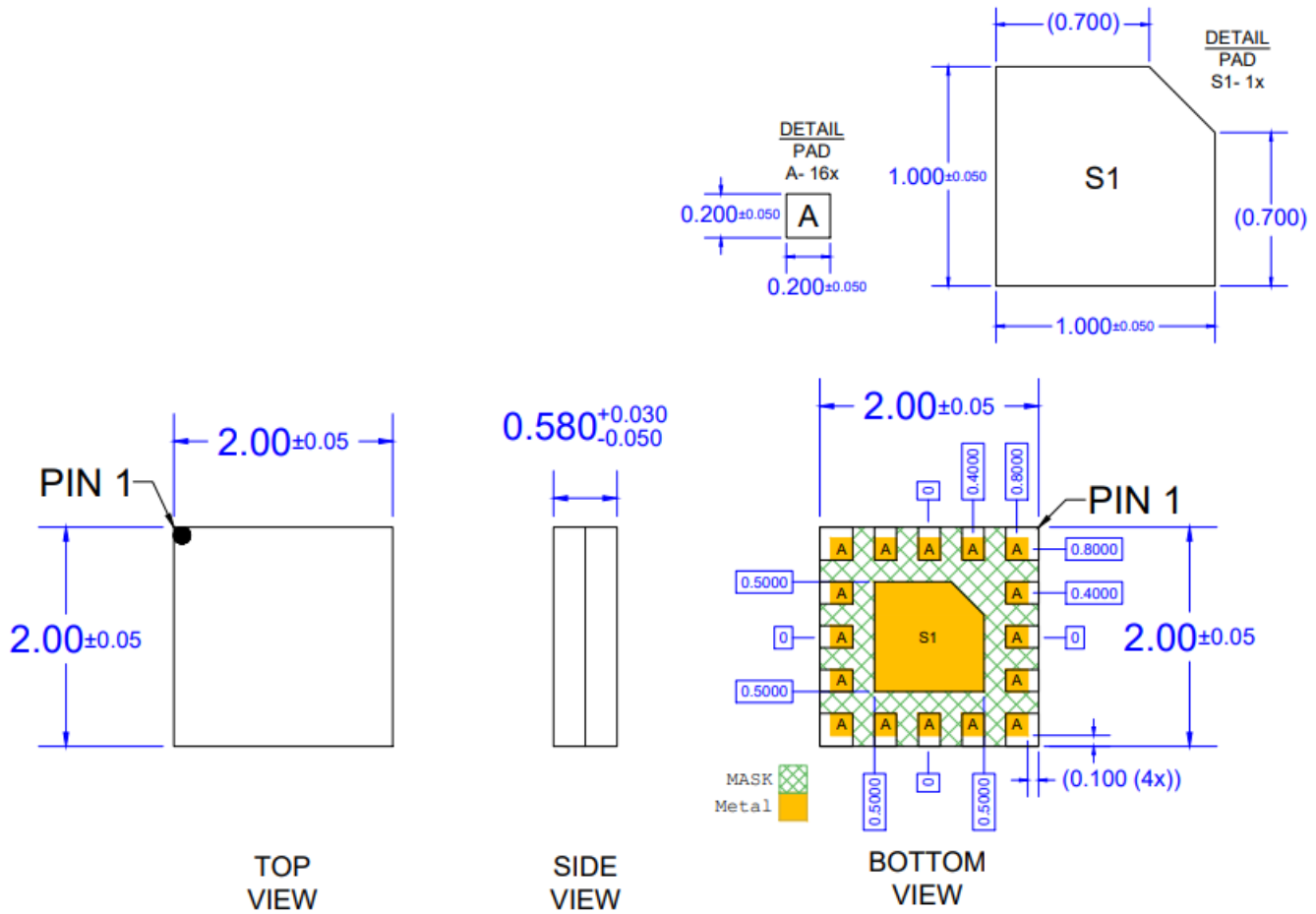

Notes:

1. All dimensions are in millimeters. Angles are in degrees.
2. Dimension and tolerance formats conform to ASME Y14.4M-1994.
3. The terminal #1 identifier and terminal numbering conform to JESD 95-1 SPP-012.

CONFIDENTIAL

Part Marking

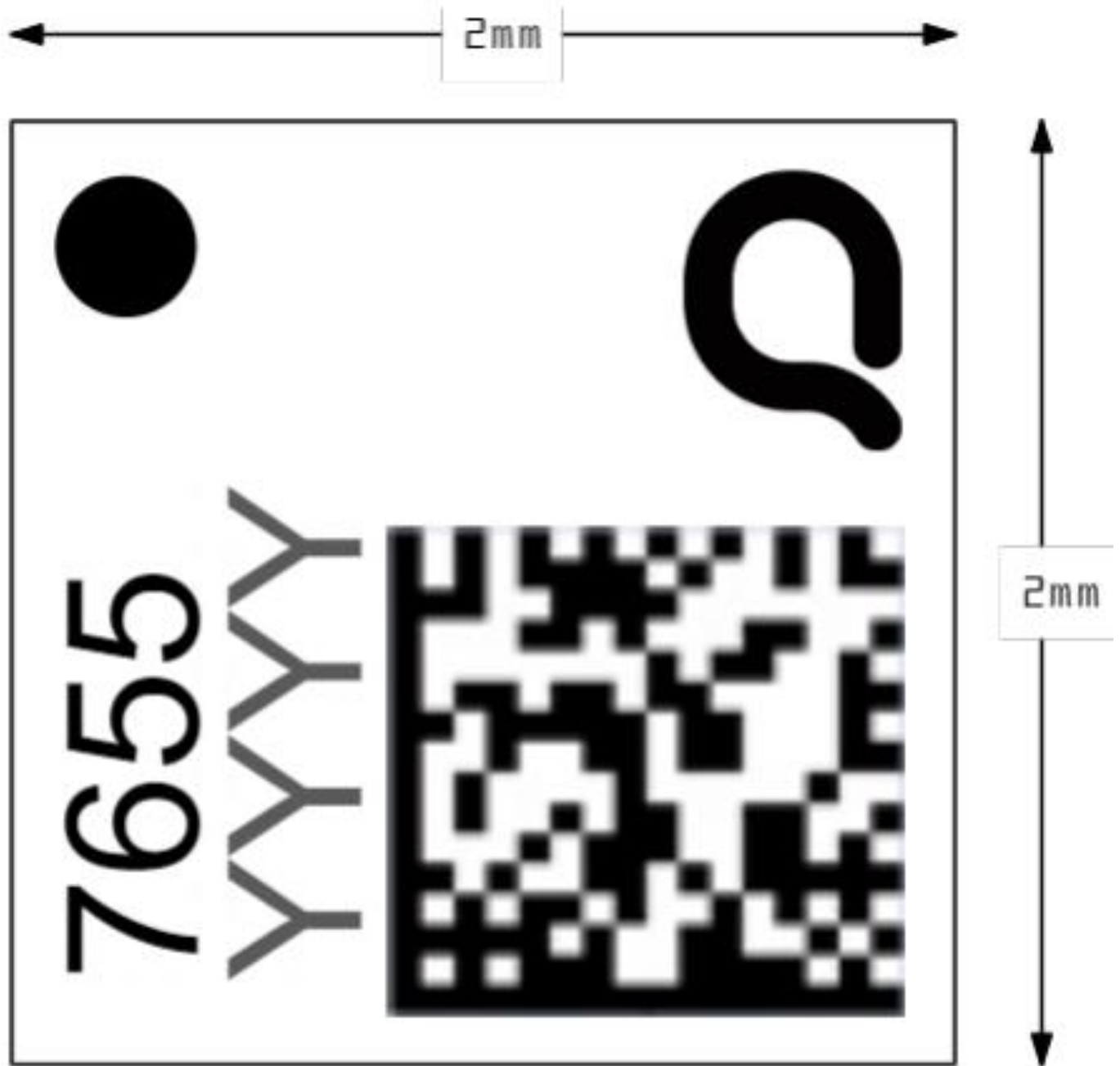

- Pin 1 Indicator
Qorvo Logo - Use Q5D
Trace Code to be assigned by SubCon

Tape and Reel Information

Tape and reel specifications for this part are also available on the Qorvo website.
Standard T/R size = 10000 pieces on a 13" reel.

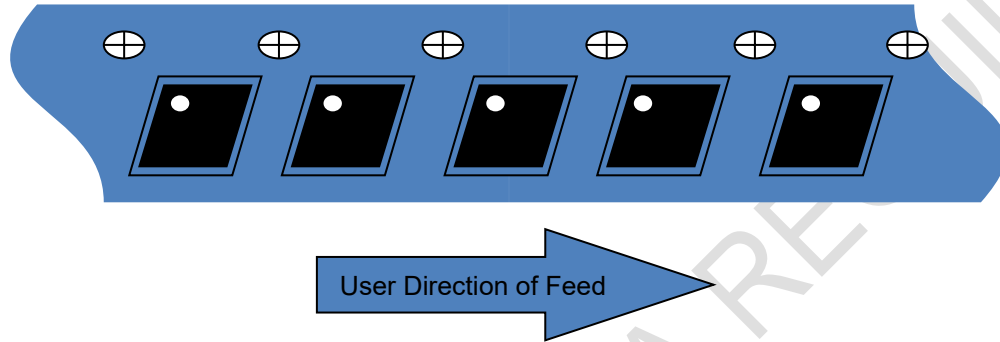

Feature	Measure	Symbol	Size (in)	Size (mm)
Cavity	Length	A0	0.087	2.20
	Width	B0	0.087	2.20
	Depth	K0	0.037	0.95
	Pitch	P1	0.157	4.00
Centerline Distance	Cavity to Perforation - Length Direction	P2	0.079	2.00
	Cavity to Perforation - Width Direction	F	0.217	5.50
Cover Tape	Width	C	0.362	9.20
Carrier Tape	Width	W	0.472	12.00

Tape and Reel Information – Reel Dimensions

Packaging reels are used to prevent damage to devices during shipping and storage, loaded carrier tape is typically wound onto a plastic take-up reel. The reel size is 13" diameter. The reels are made from high-impact injection-molded polystyrene (HIPS), which offers mechanical and ESD protection to packaged devices.

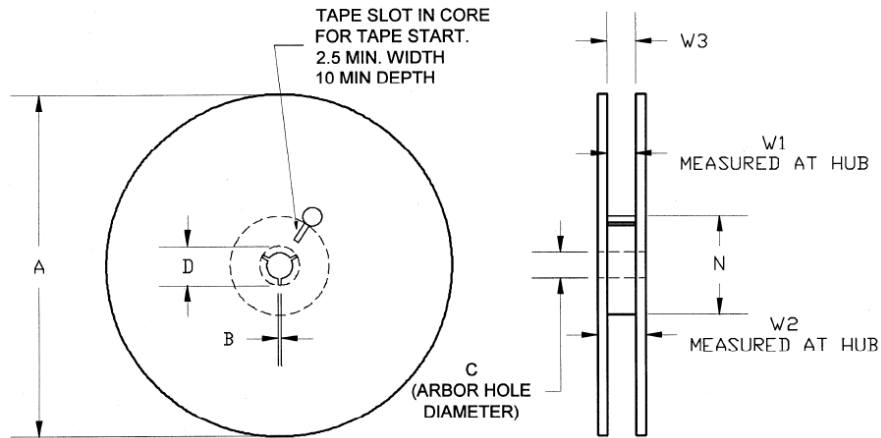

Feature	Measure	Symbol	Size (in)	Size (mm)
Flange	Diameter	A	12.992	330
	Thickness	W2	0.717	18.2
	Space Between Flange	W1	0.504	12.8
Hub	Outer Diameter	N	4.016	102.0
	Arbor Hole Diameter	C	0.512	13.0
	Key Slit Width	B	0.079	2.0
	Key Slit Diameter	D	0.787	20.0

Tape and Reel Information – Tape Length and Label Placement

Tape and reel specifications for this part are also available on the Qorvo website.
Standard T/R size = 10,000 pieces on a 13" reel

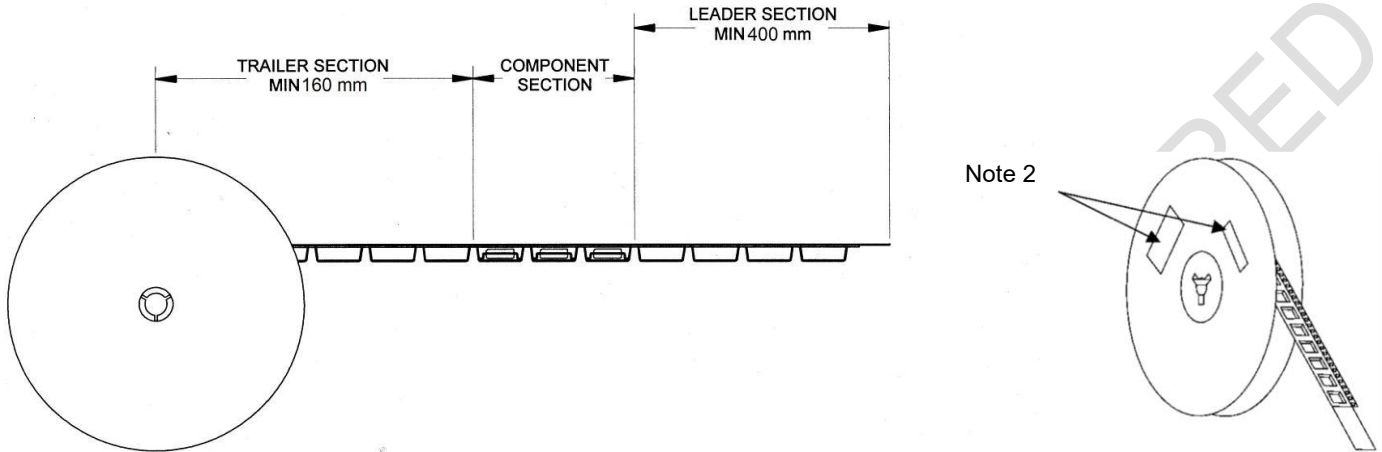

Notes:

- 1. Empty part cavities at the trailing and leading ends are sealed with cover tape. See EIA 481.
- 2. Labels are placed on the flange opposite the sprockets in the carrier tape.

Handling Precautions

Parameter	Rating	Standard	 Caution! ESD sensitive device
ESD – Human Body Model (HBM)	Class 2	ANSI/ESDA/JEDEC JS-001-2014	
ESD – Charged Device Model (CDM)	Class C3	ANSI/ESDA/JEDEC JS-002-2014	
MSL – Moisture Sensitivity Level	MSL 3	IPC/JEDEC J-STD-020	

Solderability

Compatible with both lead-free (260 °C max. reflow temperature) and tin/lead (245 °C max. reflow temperature) soldering processes. Package lead plating: ENEPIG

RoHS Compliance

This part is compliant with the 2011/65/EU RoHS directive (Restrictions on the Use of Certain Hazardous Substances in Electrical and Electronic Equipment), as amended by Directive 2015/863/EU.

This product also has the following attributes:

- Lead free
- Halogen Free (Chlorine, Bromine)
- Antimony Free
- TBBP-A (C₁₅H₁₂Br₄O₂) Free
- SVHC Free



Contact Information

For the latest specifications, additional product information, worldwide sales and distribution locations:

Web: www.qorvo.com

Tel: 1-844-890-8163

Email: customer.support@qorvo.com

Important Notice

The information contained in this Data Sheet and any associated documents (“Data Sheet Information”) is believed to be reliable; however, Qorvo makes no warranties regarding the Data Sheet Information and assumes no responsibility or liability whatsoever for the use of said information. All Data Sheet Information is subject to change without notice. Customers should obtain and verify the latest relevant Data Sheet Information before placing orders for Qorvo® products. Data Sheet Information or the use thereof does not grant, explicitly, implicitly or otherwise any rights or licenses to any third party with respect to patents or any other intellectual property whether with regard to such Data Sheet Information itself or anything described by such information.

DATA SHEET INFORMATION DOES NOT CONSTITUTE A WARRANTY WITH RESPECT TO THE PRODUCTS DESCRIBED HEREIN, AND QORVO HEREBY DISCLAIMS ANY AND ALL WARRANTIES WITH RESPECT TO SUCH PRODUCTS WHETHER EXPRESS OR IMPLIED BY LAW, COURSE OF DEALING, COURSE OF PERFORMANCE, USAGE OF TRADE OR OTHERWISE, INCLUDING THE IMPLIED WARRANTIES OF MERCHANTABILITY AND FITNESS FOR A PARTICULAR PURPOSE. Without limiting the generality of the foregoing, Qorvo® products are not warranted or authorized for use as critical components in medical, life-saving, or life-sustaining applications, or other applications where a failure would reasonably be expected to cause severe personal injury or death. Applications described in the Data Sheet Information are for illustrative purposes only. Customers are responsible for validating that a particular product described in the Data Sheet Information is suitable for use in a particular application.

© 2024 Qorvo US, Inc. All rights reserved. This document is subject to copyright laws in various jurisdictions worldwide and may not be reproduced or distributed, in whole or in part, without the express written consent of Qorvo US, Inc. | QORVO® is a registered trademark of Qorvo US, Inc.