

# QPQ5604

## Wi-Fi U-NII 5-8 band Boost BAW Filter

### Product Overview

The purpose of this application note is to help customers translate the layout and design guidelines for the Qorvo® QPQ5604 Bulk Acoustic Wave (BAW) band-pass filter.

The Qorvo® QPQ5604 is a high-performance, high power, Bulk Acoustic Wave (BAW) band-pass filter with extremely steep roll-offs, simultaneously exhibiting low loss in the Wi-Fi UNII 5 - 8 band and high near-in rejection in the UNII 1 – 3 bands.

The filter module is specifically designed to enable industry's leading capacity performance in Wi-Fi applications that result in higher power capacity in more Wi-Fi channels.

This application note serves the purpose of component integration while using advanced laminate module packaging techniques to achieve high integration in an industry leading compact footprint. And at the same time negating as many external passive component placements to assist end users ease of integration into their circuits.

### Product Details

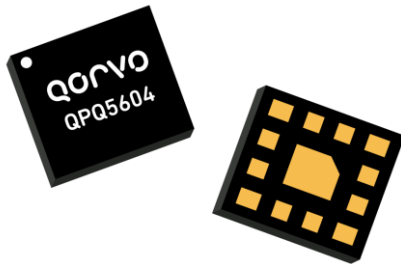

Figure 1a. Device Packaging Detail

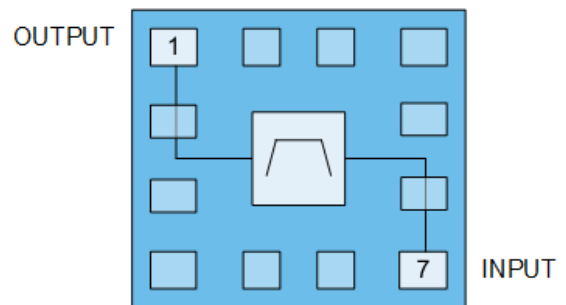

Figure 1b. Functional Block Diagram & Pin-Out Detail

Table 1. QPQ5604 Pin Description

PIN NUMBER	LABEL	DESCRIPTION
1	OUTPUT	RF Output. Internally matched to 50Ω.
7	INPUT	RF Input. Internally matched to 50Ω.
All other Pads	GND	RF Ground connection. Use recommended via pattern to minimize inductance and thermal resistance.

#### Notes:

- Pin 1 is the unidirectional large signal output port and pin 7 is the unidirectional large signal input port.
- The Transmit (Pin 1) and Antenna (Pin 7) ports are both bidirectional for small signals only.
- It's recommended not to exceed the max power handling conditions specified on the data sheet or permanent damage may occur.

## Evaluation Board Information

The Qorvo® QPQ5604 evaluation board is designed to provide performance representative of that obtainable in an actual application. The evaluation board is designed to operate with 50Ω load impedances at all RF ports, which are provided with SMA connector interfaces.

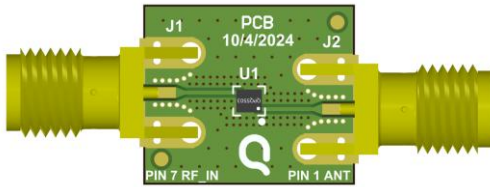

Figure 2a. QPQ5604 Evaluation Board PCB

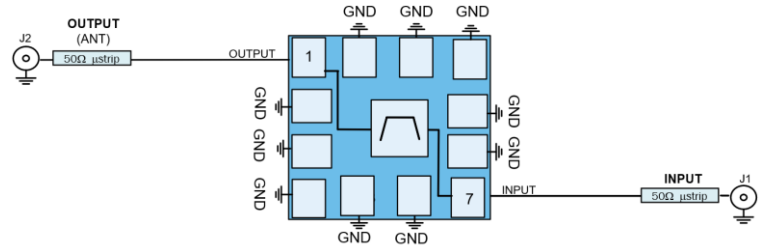

Figure 2b. QPQ5604 Evaluation Board Schematic

Table 2. QPQ5604 PCB Stack-Up

LAYER	NAME	MATERIAL	THICKNESS	DIELECTRIC CONSTANT
	Top Overlay	-	-	-
	Top Solder	Solder Resist	0.0008in	
1	Top Layer	Copper	0.0007in	-
	Dielectric 1	Rogers 4350B	0.0066in	3.48
2	Layer 2/ Metal 2	Copper	0.0007in	-
	Dielectric 2	FR4	0.045in	4.1
3	Layer 3/ Metal 3	Copper	0.0007in	-
	Dielectric 3	FR4	0.006in	4.1
4	Bottom Layer/ Metal 4	Copper	0.0007in	-
	Bottom Solder	Solder Resist	0.0008in	3.5
	Bottom Overlay	-	-	-

Note:

Total PCB Thickness: 0.062in

Table 3. QPQ5604 Evaluation Board Bill of Materials

REF. DES.	VALUE	DESCRIPTION	MANUF.	PART NUMBER
-	-	Printed Circuit Board		
U1	-	6GHz bandBoost U-NII 5-8 Filter	Qorvo	QPQ5604

## System Architecture Application Circuit Recommendations

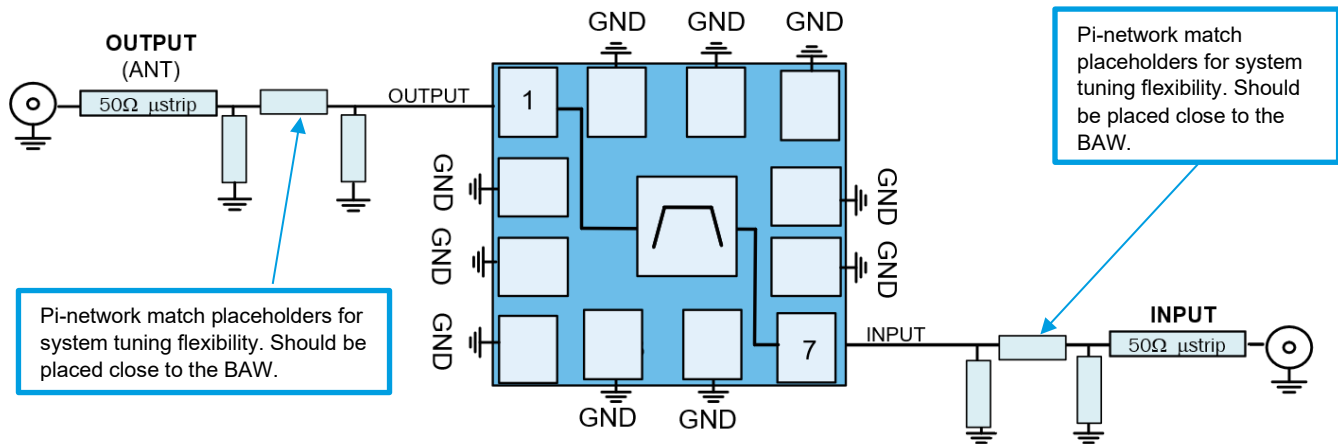

Figure 3. Recommended Application Circuit in a System

### RF Matching Considerations

The above schematic shows Qorvo® recommended Pi-network match placeholders for system tuning flexibility based on the QPQ5604 evaluation board and should be placed close to the BAW.

- The customer should ensure that sufficient Pi-matching is provided based on their PCB layout.
- If additional out-of-band rejections/ attenuations are needed the matching at the output port will help to improve the filtering.
- Matching at the Input port side of the BAW will help in improving the in-band ripple and insertion loss.

### PCB Layout Considerations

The board layout must be carefully considered to achieve optimal performance from any BAW filter, including the QPQ5604. In addition to providing connectivity between the BAW and external components, the PCB layout is a part of the overall circuit. The PCB parasitics of the RF traces, along with coupling between traces, must be evaluated. The QPQ5604 evaluation board PCB layout guidelines provide a good starting point for designing the layout in the actual application.

### RF and DC Trace Routing

All PCB traces between the RF pins and matching networks (where applicable) should be 50Ω controlled impedance lines, as should the traces between the matching networks and the next component in the chain. RF traces should be isolated from other RF and DC signals from other components by adding solid ground planes (with vias) between them to minimize coupling or cross-talking. All DC traces routed near the BAW must be isolated from the BAW with a GND in between the BAW and the DC trace. Qorvo® recommends to avoid routing traces/ tracks underneath the BAW.

In addition, Qorvo® also recommends reducing RF trace lengths, wherever possible. Fenced or shielding vias are recommended around RF traces to help maintain a low impedance or short return current path.

### Grounding Considerations

**Grounding of BAW GND pad** – The ground pad serves as the primary RF ground reference for the entire BAW. Connect the BAW filter ground pad directly to the main ground plane layer of the PCB. The PCB ground layer should be close to the component layer, preferably the next layer down to minimize the lengths of via connections between the component and ground layers. Ground paths (under device) should be made as short as possible to reduce inductance. Although the QPQ5604 Evaluation Board uses Blind vias

routed from the top layer through to the 2<sup>nd</sup> layer ground underneath the BAW, this type of via is not mandatory. They can be routed from the top layer to the bottom layer GND without any performance changes to the BAW and is the preferred method.

**Reference Plane Ground** – Qorvo® recommends distributing a large number of via holes over the entire area below/around the BAW to provide good RF ground reference ground plane, as shown in the thermal via array pattern in **Figure 4** below. The GND planes on the rest of the PCB should have vias on them which route from the top layer through to the bottom GND layer.

**GND Vias for Thermal Considerations** – The BAW GND pins serve as the primary path for heat removal, additionally, the PCB ground vias will serve as a low resistance thermal path between the BAW and the PCB. Vias passing through multiple copper layers provide the best overall RF and thermal performance. The QPQ5604 ground pad has special electrical and thermal grounding requirements. This pad is the main RF ground and main thermal conduction path for heat dissipation. The GND pad, vias pattern, size, and type used on the Qorvo® evaluation board should be replicated on the final product. The Qorvo® layout files in Gerber format can be provided to the reader upon request.

- The QPQ5604 evaluation board uses GND vias with an 5mil hole size and 10mil diameter along RF traces.
- Qorvo recommends using GND vias between 3.8 and 8mil hole size and to follow the thermal via array patterns similar to what’s shown in **Figure 4**.
- Qorvo® recommends using a **Direct Connect** ground connection underneath the QPQ5604 rather than use the Thermal Relief style ground connection.
- The Qorvo® QPQ5604 Evaluation Board uses Filled Vias on the GND pad. It is recommended to have GND vias on all GND pins.

Figure 4. Recommended 10-Via count GND via Pattern

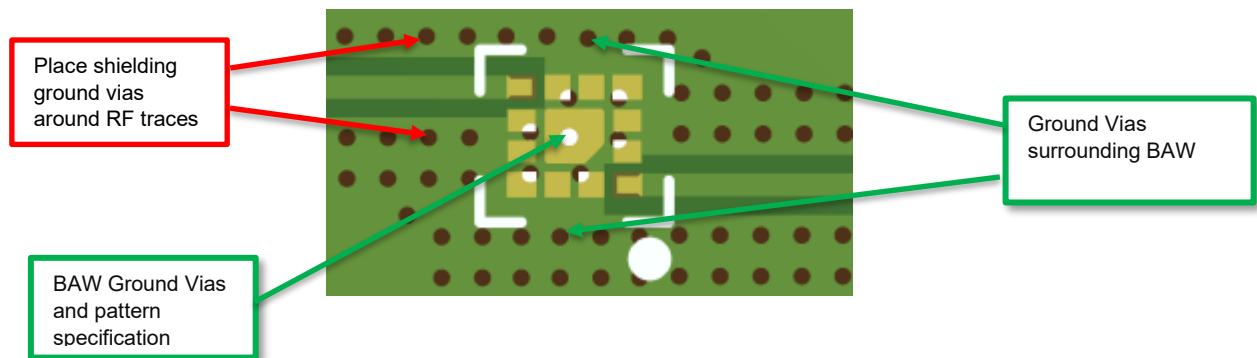

## Land Pattern Recommendation

### PCB Footprint Recommendations

See **Figures 5a and 5b** below for the Qorvo<sup>®</sup> recommended package outline drawing and solder mask patterns.

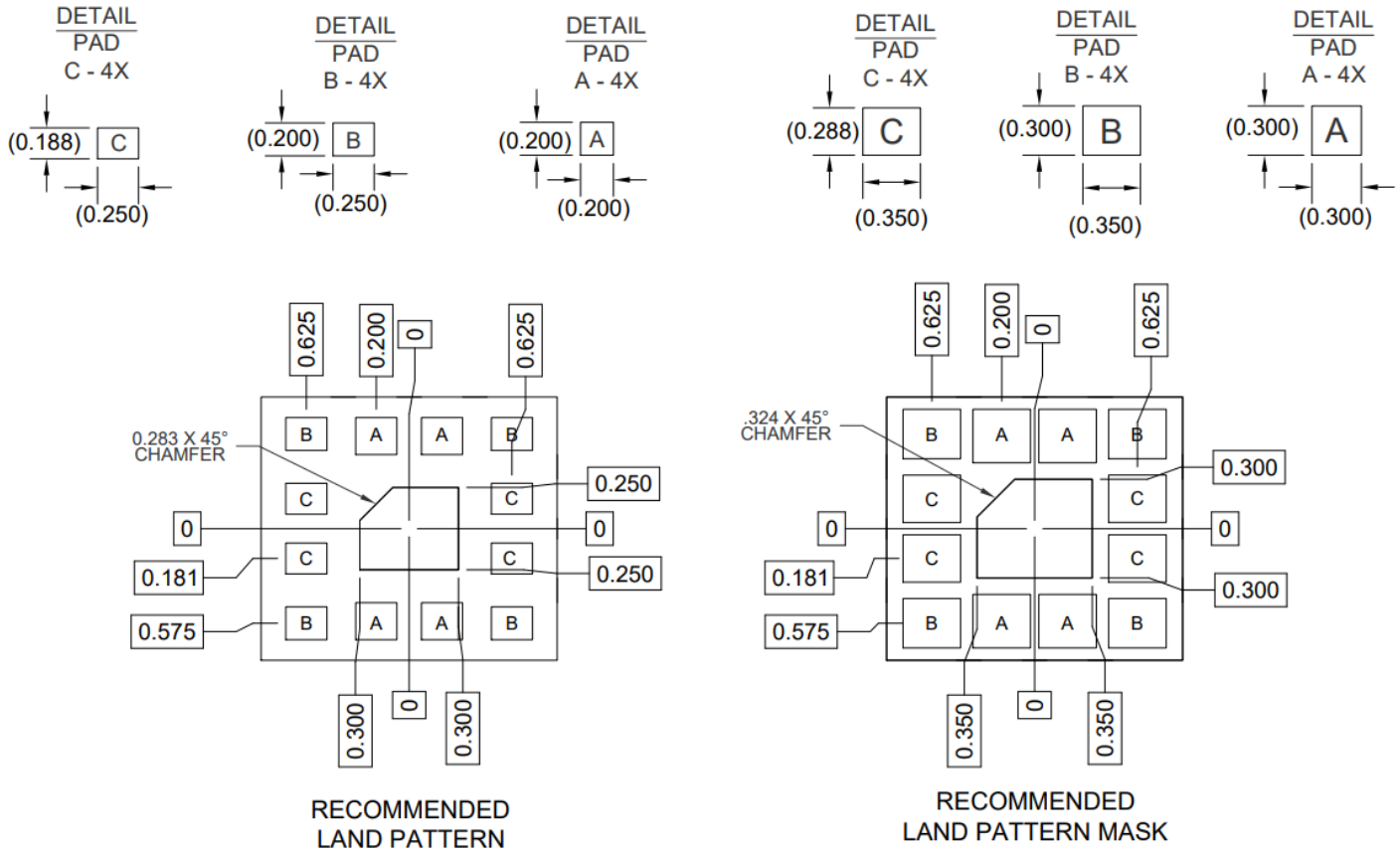

Figure 5a. PCB Footprint Recommended Landing Pattern

Figure 5b. PCB Footprint Recommended Solder Mask Pattern

**Notes:**

1. All dimensions shown are in millimeters. Angles are in degrees.
2. Dimension and tolerance formats conform to ASME Y14.4M-1994.
3. The terminal #1 identifier and terminal numbering conform to JESD 95-1 SPP-012.
4. Qorvo<sup>®</sup> recommends to use a 2mil e-FAB stencil.

## Package Information

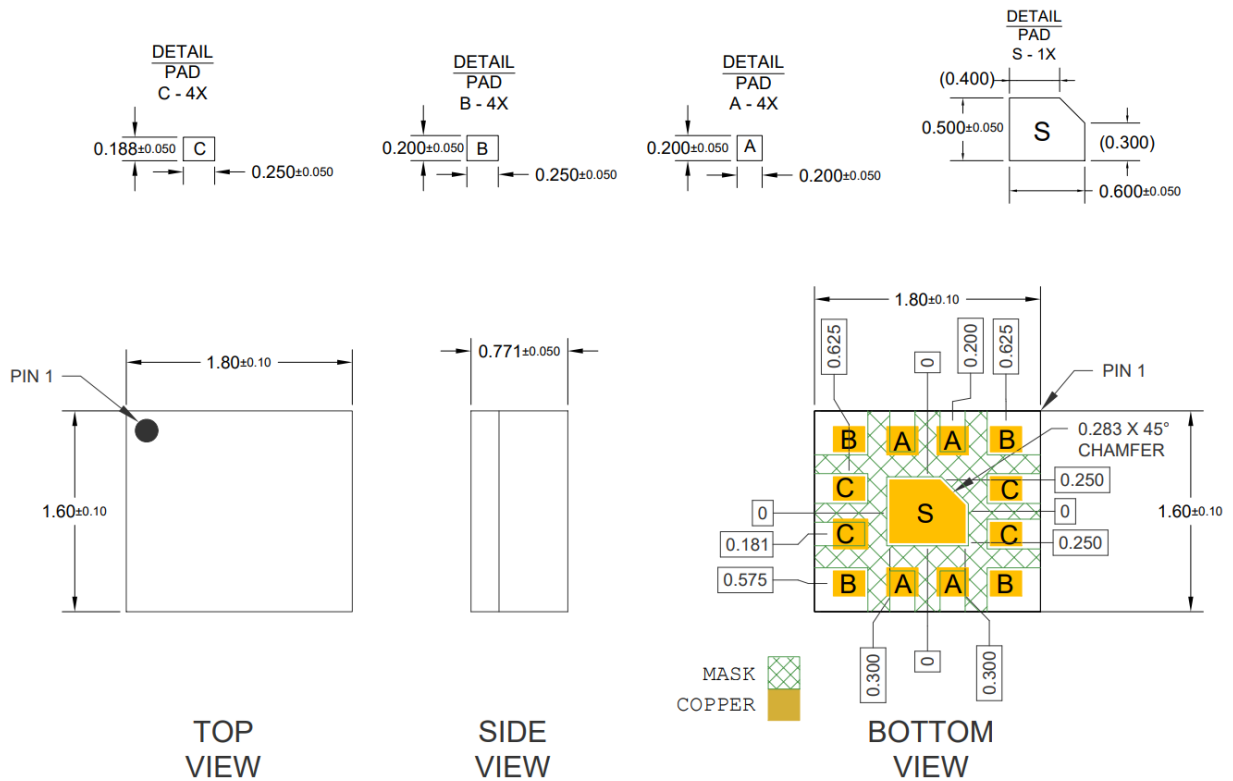

Figure 6a. Marking Diagram

Figure 6b. QPQ5604 Package Outline Drawing

Package Style: Laminate  
 Dimensions: 1.8 x 1.6 x 0.771 mm

Notes:

1. All dimensions shown are in millimeters. Angles are in degrees.
2. This drawing specifies the mounting pattern used on the Qorvo® evaluation board for this product.
3. Some modifications may be necessary to suit end user assembly materials and processes.

## Support Data

For any further data on the QPQ5604, please request Qorvo® point of contact such as marketing, sales or a representative in your region.

## Additional Information

For information on ESD, Soldering Profiles, Packaging Standards, Handling and Assembly, please contact Qorvo® for general guidelines.

## Contact Information

For the latest specifications, additional product information, worldwide sales and distribution locations:

**Web:** [www.qorvo.com](http://www.qorvo.com)

**Tel:** 1-844-890-8163

**Email:** [customer.support@qorvo.com](mailto:customer.support@qorvo.com)

## Important Notice

The information contained herein is believed to be reliable; however, Qorvo makes no warranties regarding the information contained herein and assumes no responsibility or liability whatsoever for the use of the information contained herein. All information contained herein is subject to change without notice. Customers should obtain and verify the latest relevant information before placing orders for Qorvo products. The information contained herein or any use of such information does not grant, explicitly or implicitly, to any party any patent rights, licenses, or any other intellectual property rights, whether with regard to such information itself or anything described by such information. **THIS INFORMATION DOES NOT CONSTITUTE A WARRANTY WITH RESPECT TO THE PRODUCTS DESCRIBED HEREIN, AND QORVO HEREBY DISCLAIMS ANY AND ALL WARRANTIES WITH RESPECT TO SUCH PRODUCTS WHETHER EXPRESS OR IMPLIED BY LAW, COURSE OF DEALING, COURSE OF PERFORMANCE, USAGE OF TRADE OR OTHERWISE, INCLUDING THE IMPLIED WARRANTIES OF MERCHANTABILITY AND FITNESS FOR A PARTICULAR PURPOSE.**

Without limiting the generality of the foregoing, Qorvo products are not warranted or authorized for use as critical components in medical, life-saving, or life-sustaining applications, or other applications where a failure would reasonably be expected to cause severe personal injury or death.

Copyright 2025 © Qorvo, Inc. | Qorvo is a registered trademark of Qorvo, Inc.