

# QPA9119 - 1.7-2.3GHz Reference Document

## Product Overview

---

The QPA9119 is a high linearity driver amplifier in a low-cost, RoHS compliant, surface mount package. This InGaP/GaAs HBT delivers high performance across a broad range of frequencies with +44 dBm OIP3 and +27.2 dBm P1dB while only consuming 130 mA quiescent current. All devices are 100% RF and DC tested.

The QPA9119 incorporates on-chip features that differentiate it from other products in the market. The amplifier integrates an on-chip DC over-voltage and RF over-drive protection. This protects the amplifier from electrical DC voltage surges and high input RF input power levels that may occur in a system. On-chip ESD protection allows the amplifier to have a very robust Class 1C HBM ESD rating.

The QPA9119 is targeted for use as a driver amplifier in wireless infrastructure where high linearity, medium power, and high efficiency are required. The device is an excellent candidate for transceiver line cards in current and next generation multi-carrier 3G / 4G base stations.

## Referenced Documents

The reference documents below take precedence over the contents of this application note, and should always be consulted for the latest information.

QPA9119 Data Sheet.

## APPLICATION NOTE: QPA9119 - 1.7-2.3GHz Reference Document

## Application Electrical Performance

Qorvo Field and Factory Applications Engineers are available to provide technical assistance for determining appropriate matching networks for a particular application.

Parameter	Conditions	Typical Value			Units
Frequency		1800	2000	2200	MHz
Gain		14.4	14.5	14.1	dB
Input Return Loss		7.4	13.7	18.0	dB
Output Return Loss		11.0	10.9	10.5	dB
Output P1dB		+27.9	+27.8	+27.8	dBm
Output IP3	Pout= +15 dBm/tone, $\Delta f = 1$ MHz	+45.9	+45.5	+44.5	dBm
Quiescent Collector Current, $I_{CQ}$		135			mA

Test conditions unless otherwise noted: VCC = VPD = +5.0V, Temp = +25 °C, 50  $\Omega$  system.

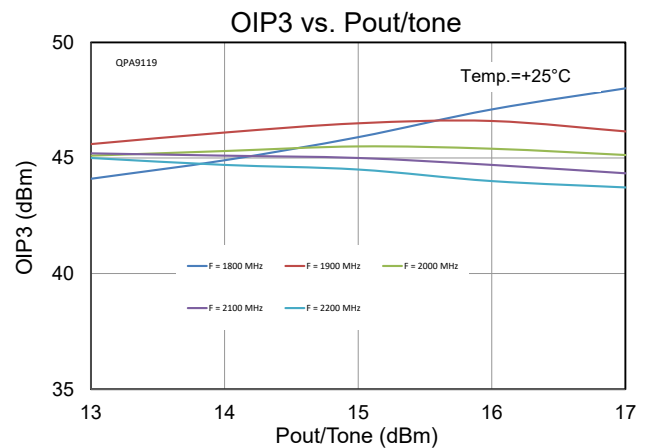
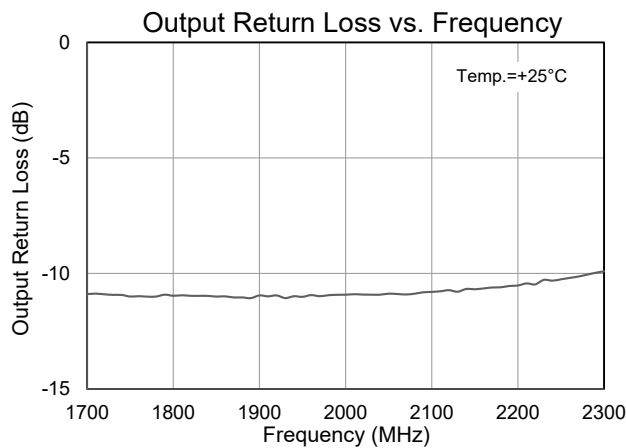
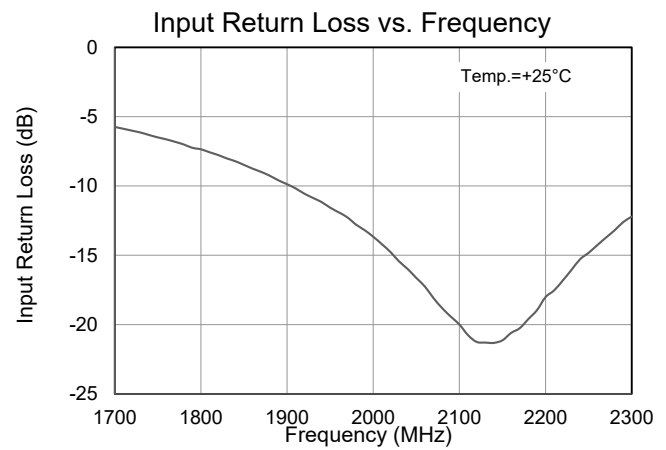
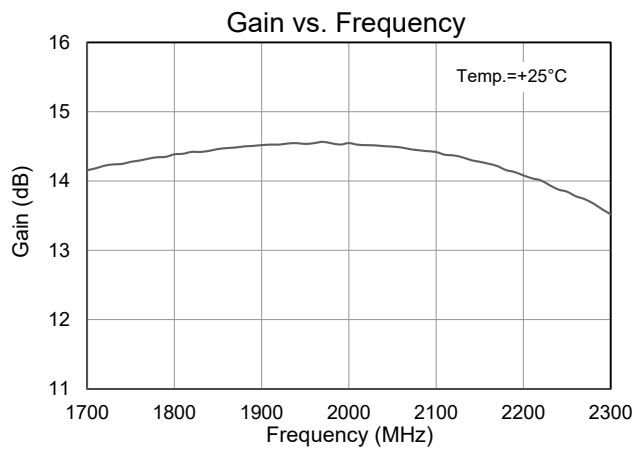

APPLICATION NOTE: QPA9119 - 1.7-2.3GHz Reference Document

## Evaluation Board Information

### Evaluation Board Schematic

SCALE - 4:1 Note: 0603 and 0805 components shown 25% larger than actual size.

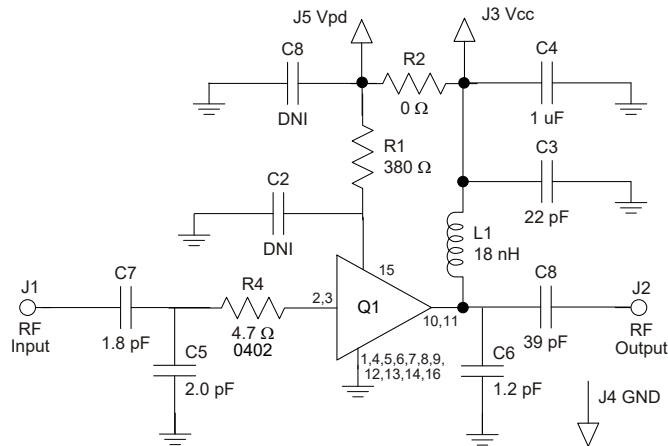
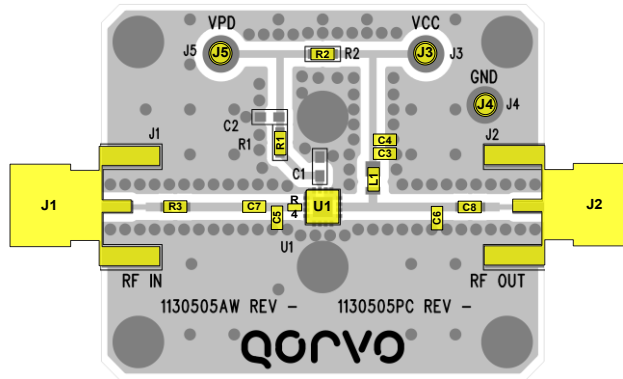

Notes:

1. All components are of 0603 size unless stated on the schematic.
2. The recommended component values are dependent upon the frequency of operation.
3. Critical component placement locations:
  - Distance between U1 (left edge) to R4 (right edge): 15 mil
  - Distance between U1 (left edge) to C5 (right edge): 75 mil
  - Distance between U1 (left edge) to C7 (right edge): 130 mil
  - Distance between U1 (right edge) to C6 (left edge): 260 mil

## APPLICATION NOTE: QPA9119 - 1.7-2.3GHz Reference Document

## Evaluation Board Bill of Material

Reference Des.	Value	Description	Manuf.	Part Number
n/a	n/a	Printed Circuit Board	Qorvo	
U1	n/a	QPA9119 Amplifier, QFN pkg.	Qorvo	QPA9119
R1	380 $\Omega$	Res., Chip, 0603, +/-1%, 1/10W	various	
R2, R3	0 $\Omega$	Res., Chip, 0603	various	
C5	2.0 pF	CAP, 0603, +/-0.1pF. 200V. NPO/COG	various	
C6	1.2 pF	CAP, 0603, +/-0.1pF. 200V. NPO/COG	various	
C7	1.8pF	CAP, 0603, +/-0.1pF. 200V. NPO/COG	various	
C8	39 pF	Cap., Chip, 0603, +/-5%. 50V NPO/COG	various	
C3	22 pF	Cap., Chip, 0603, +/-5%. 50V NPO/COG	various	
R4	4.7 $\Omega$	Res., Chip, 0603, +/-1%, 1/10W	various	
C4	1.0 uF	CAP, 0603, 10%, X5R, 10V	various	
L1	18 nH	Inductor, 0805, 5%, Coilcraft CS series	Coilcraft	0805CS-180XJLB

APPLICATION NOTE: QPA9119 - 1.7-2.3GHz Reference Document

**Evaluation Board PCB Board Layers**

**PC Board Layout**

PCB 1130505 Material (stack up)

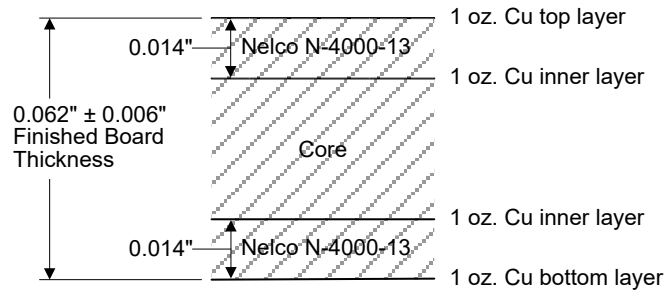

50-ohm line dimensions: width = 0.029", spacing = 0.029"

APPLICATION NOTE: QPA9119 - 1.7-2.3GHz Reference Document

## Additional Information

For information on ESD, Soldering Profiles, Packaging Standards, Handling and Assembly, please contact Qorvo for general guidelines.

## Contact Information

For the latest specifications, additional product information, worldwide sales and distribution locations:

**Web:** [www.qorvo.com](http://www.qorvo.com)

**Tel:** 1-844-890-8163

**Email:** [customer.support@qorvo.com](mailto:customer.support@qorvo.com)

## Important Notice

The information contained in this Data Sheet and any associated documents (“Data Sheet Information”) is believed to be reliable; however, Qorvo makes no warranties regarding the Data Sheet Information and assumes no responsibility or liability whatsoever for the use of said information. All Data Sheet Information is subject to change without notice. Customers should obtain and verify the latest relevant Data Sheet Information before placing orders for Qorvo® products. Data Sheet Information or the use thereof does not grant, explicitly, implicitly or otherwise any rights or licenses to any third party with respect to patents or any other intellectual property whether with regard to such Data Sheet Information itself or anything described by such information.

DATA SHEET INFORMATION DOES NOT CONSTITUTE A WARRANTY WITH RESPECT TO THE PRODUCTS DESCRIBED HEREIN, AND QORVO HEREBY DISCLAIMS ANY AND ALL WARRANTIES WITH RESPECT TO SUCH PRODUCTS WHETHER EXPRESS OR IMPLIED BY LAW, COURSE OF DEALING, COURSE OF PERFORMANCE, USAGE OF TRADE OR OTHERWISE, INCLUDING THE IMPLIED WARRANTIES OF MERCHANTABILITY AND FITNESS FOR A PARTICULAR PURPOSE. Without limiting the generality of the foregoing, Qorvo® products are not warranted or authorized for use as critical components in medical, life-saving, or life-sustaining applications, or other applications where a failure would reasonably be expected to cause severe personal injury or death. Applications described in the Data Sheet Information are for illustrative purposes only. Customers are responsible for validating that a particular product described in the Data Sheet Information is suitable for use in a particular application.

© 2025 Qorvo US, Inc. All rights reserved. This document is subject to copyright laws in various jurisdictions worldwide and may not be reproduced or distributed, in whole or in part, without the express written consent of Qorvo US, Inc. | QORVO® is a registered trademark of Qorvo US, Inc.