

QPA9121 - 1.8GHz-2.2GHz Reference Design

Product Overview

The QPA9121 is a wideband, high gain, and high linearity driver amplifier in a low-cost, RoHS compliant 3x3 mm laminate. With Qorvo's GaAs HBT process, this amplifier delivers exceptional performance with 35 dBm OIP3 and 24 dBm output P1dB while consuming less than 90 mA quiescent current with single 5V supply.

The QPA9121 incorporates on-chip features with fast DC power shutdown, externally configurable device DC operation current, and 50 ohms matching at all RF ports.

The QPA9121 is targeted for use as a driver amplifier for wireless infrastructure where high linearity, high power and efficient DC power operation are required. The device is an excellent choice for 5G dense-array m-MIMO radio applications.

Referenced Documents

The reference documents below take precedence over the contents of this application note, and should always be consulted for the latest information.

QPA9121 Data Sheet.

APPLICATION NOTE: QPA9121 - 1.8GHz-2.2GHz Reference Design

Application Electrical Performance

Qorvo Field and Factory Applications Engineers are available to provide technical assistance for determining appropriate matching networks for a particular application.

Parameter	Conditions	Typical Value			Units
		1800	2100	2200	
Frequency		1800	2100	2200	MHz
Gain		28.6	29.8	28.4	dB
Input Return Loss		3.9	11.6	5.4	dB
Output Return Loss		10.4	10.2	9.7	dB
Output P1dB		24.7	25.3	25.5	dBm
Device Current	V _{CC} and V _{CC1}	95			mA

Test conditions unless otherwise noted: V_{CC} = V_{CC1} = +5V, I_{CC} = 95mA, V_{PD} = +1.8V, Temp = +25 °C, 50 Ω system.

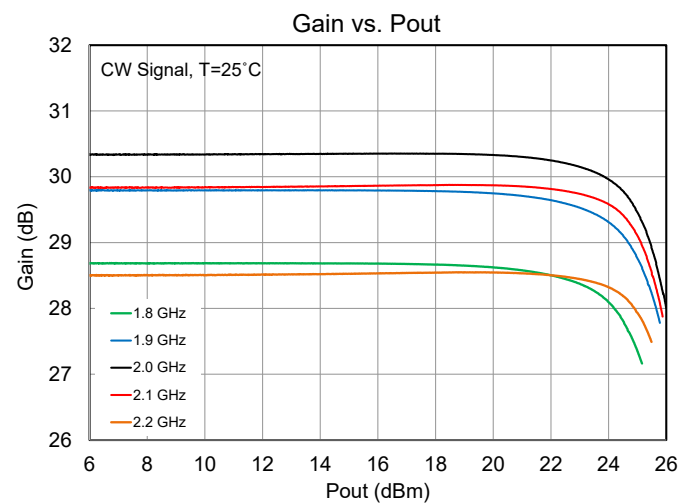
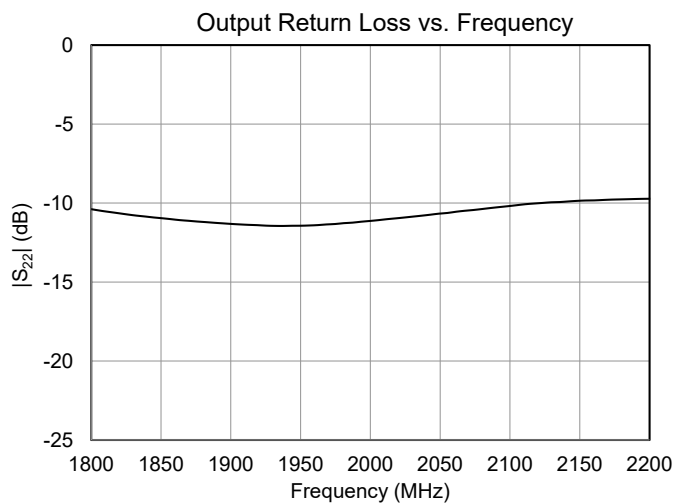
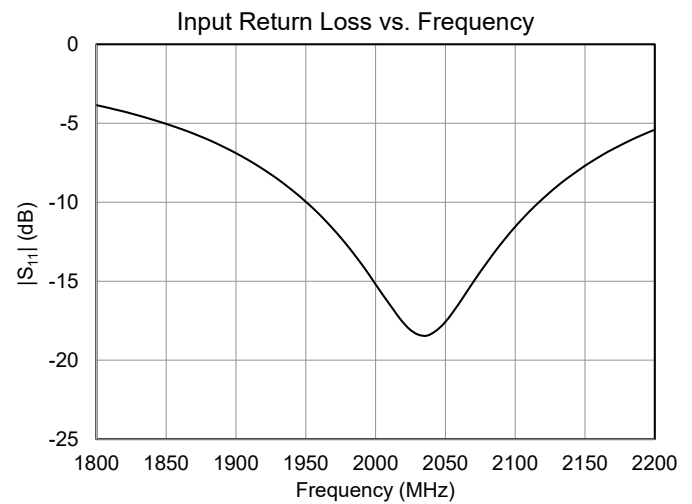
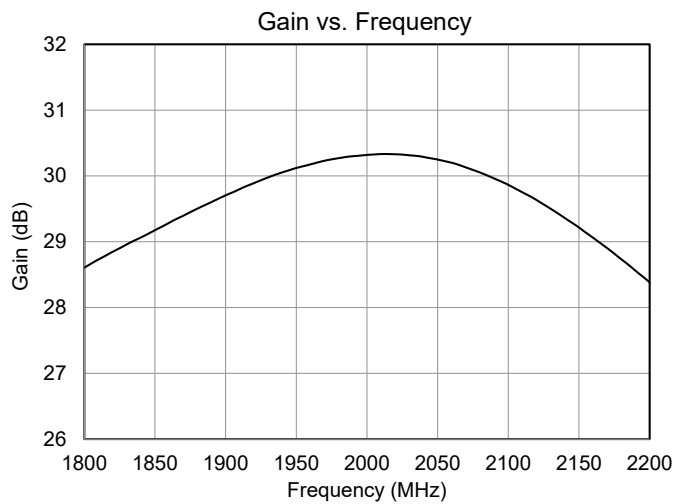

APPLICATION NOTE: QPA9121 - 1.8GHz-2.2GHz Reference Design

Evaluation Board Information

Evaluation Board and Schematic

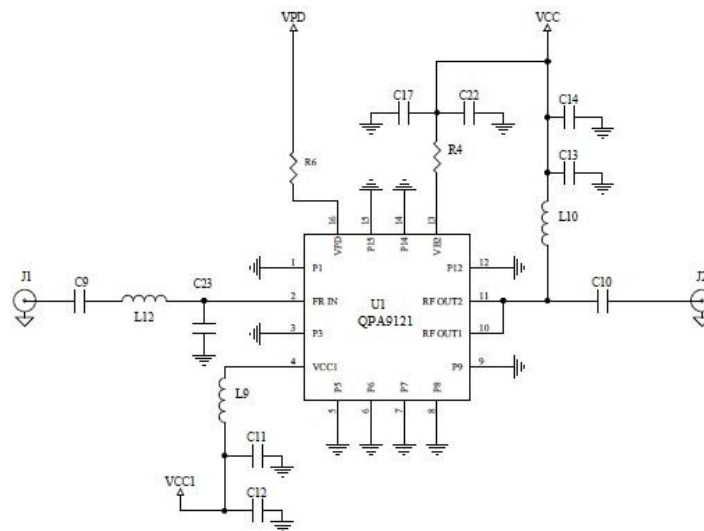
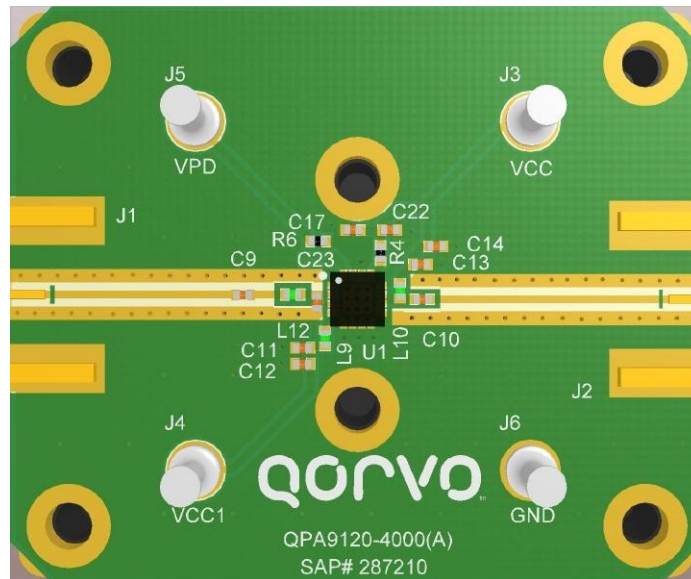

Notes:

1. Components shown on PCB layout but not on the schematic are not used.
2. Critical component placement locations:
 - Distance between U1 (left edge) to C23 (right edge): 0.50 mm
 - Distance between U1 (left edge) to L12 (right edge): 1.55 mm
 - Distance between U1 (left edge) to C9 (right edge): 4.65 mm

APPLICATION NOTE: QPA9121 - 1.8GHz-2.2GHz Reference Design

Evaluation Board – Bill of Material

Reference Des.	Value	Description	Manuf.	Part Number
n/a	-	Printed Circuit Board	Qorvo	
U1	-	High Gain Driver Amplifier	Qorvo	QPA9121
C9, C10	18 pF	CAP, 5%, 50V, C0G, 0402	Murata	GRM1555C1H180JA01D
C12, C14	1 μ F	CAP, 10V, X5R, CER, 0402	Various	
C11, C13, C17, C22	100 pF	CAP, 5%, 50V, C0G, 0402	Murata	GRM1555C1H101JA01D
R4	51 Ω	RES, 5%, 1/16W, 0402	Various	
R6	0 Ω	RES, 1/10W, 0402	Various	
L9	8.2 Ω	RES, 5%, 1/16W, 0402	Various	
L10	12 nH	IND, 5%, 0402	Coilcraft	0402CS-12NXJLW
R5, R7	DNP	n/a	n/a	n/a
L12	6.8 nH	IND, 5%, 0402	Coilcraft	0402CS-6N8XJW
C23	1.3 pF	CAP, 50V, C0G, 0402	Murata	GJM1555C1H1R3BB01
J1, J2	-	Conn, SMA F STRT .062"	Cinch Connectivity	142-0701-851

APPLICATION NOTE: QPA9121 - 1.8GHz-2.2GHz Reference Design

Additional Information

For information on ESD, Soldering Profiles, Packaging Standards, Handling and Assembly, please contact Qorvo for general guidelines.

Contact Information

For the latest specifications, additional product information, worldwide sales and distribution locations:

Web: www.qorvo.com

Tel: 1-844-890-8163

Email: customer.support@qorvo.com

Important Notice

The information contained in this Data Sheet and any associated documents ("Data Sheet Information") is believed to be reliable; however, Qorvo makes no warranties regarding the Data Sheet Information and assumes no responsibility or liability whatsoever for the use of said information. All Data Sheet Information is subject to change without notice. Customers should obtain and verify the latest relevant Data Sheet Information before placing orders for Qorvo® products. Data Sheet Information or the use thereof does not grant, explicitly, implicitly or otherwise any rights or licenses to any third party with respect to patents or any other intellectual property whether with regard to such Data Sheet Information itself or anything described by such information.

DATA SHEET INFORMATION DOES NOT CONSTITUTE A WARRANTY WITH RESPECT TO THE PRODUCTS DESCRIBED HEREIN, AND QORVO HEREBY DISCLAIMS ANY AND ALL WARRANTIES WITH RESPECT TO SUCH PRODUCTS WHETHER EXPRESS OR IMPLIED BY LAW, COURSE OF DEALING, COURSE OF PERFORMANCE, USAGE OF TRADE OR OTHERWISE, INCLUDING THE IMPLIED WARRANTIES OF MERCHANTABILITY AND FITNESS FOR A PARTICULAR PURPOSE. Without limiting the generality of the foregoing, Qorvo® products are not warranted or authorized for use as critical components in medical, life-saving, or life-sustaining applications, or other applications where a failure would reasonably be expected to cause severe personal injury or death. Applications described in the Data Sheet Information are for illustrative purposes only. Customers are responsible for validating that a particular product described in the Data Sheet Information is suitable for use in a particular application.

© 2025 Qorvo US, Inc. All rights reserved. This document is subject to copyright laws in various jurisdictions worldwide and may not be reproduced or distributed, in whole or in part, without the express written consent of Qorvo US, Inc. | QORVO® is a registered trademark of Qorvo US, Inc.