

### Product Overview

The QPL1842 is a GaAs pHEMT differential MMIC RF amplifier IC featuring 25dB of gain and low noise from 5MHz to 834MHz. This high linearity IC is designed to support Broadband CATV DOCSIS 4.0 applications, such as Nodes, Amplifiers, and Remote PHY Devices, as well as Fiber to The Home (FTTH), Home Gateways, and Cable Modems. The combination of low noise, excellent distortion, and high gain make this suitable for drop amps and other distribution amps. The device is powered by a single supply and can operate from 5V/250mA to 8V/350mA. At 5V, from 5-834MHz, the QPL1842 provides an output of 64.5dBmV TCP with a CCN of 51dB. The device is packaged in a 12-pin 5x5mm<sup>2</sup> Laminate Module.



5 x 5 12-pin Laminate MCM Package

### Functional Block Diagram

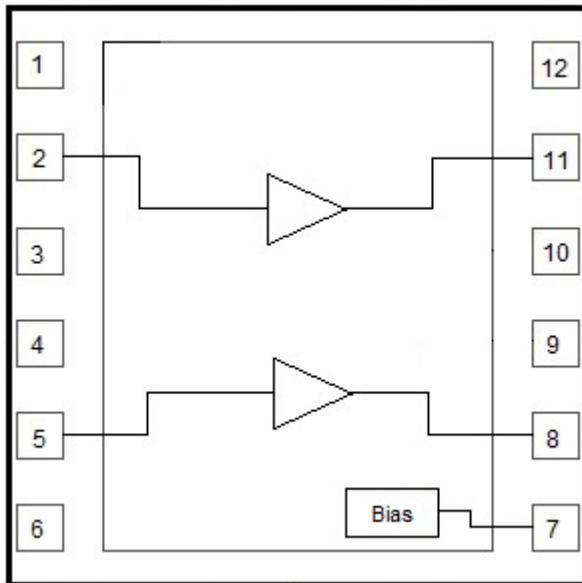

### Key Features

- 5 MHz to 834MHz Operation 5V & 8V
- Gain: 25dB Typical
- TCP: 64.5dBmV @ 5V & 67.5dBmV @ 8V
- Noise Figure: 1.8dB @ 700MHz; 2.0dB @ 834MHz
- Adjustable Bias Using External Resistors

### Applications

- DOCSIS 4.0 Amplifiers
- DOCSIS 4.0 Optical Nodes
- DOCSIS 4.0 Remote PHY Devices
- FTTH GPON and GEPON
- DOCSIS 4.0 Cable Modem and Home Gateways

### Ordering Information

Part Number	Description
QPL1842EVB-02	5V Upstream Evaluation Board
QPL1842EVB-04	8V Upstream Evaluation Board

Part Number	Description
QPL1842SB	Sample bag with 5 pieces
QPL1842SR	7" Reel with 100 pieces
QPL1842TR13	13" Reel with 2500 pieces



## Table of Contents

Product Overview .....	1
Functional Block Diagram .....	1
Key Features .....	1
Applications .....	1
Ordering Information .....	1
Absolute Maximum Ratings .....	3
Electrical Specifications .....	3
Evaluation Board Assembly Drawing .....	4
Evaluation Board Schematic 5 – 834MHz, 5V .....	5
Evaluation Board Bill of Materials for 5V .....	5
Performance Data, 5V, 5-834MHz .....	6
Evaluation Board Schematic 5 – 834MHz, 8V .....	11
Evaluation Board Bill of Materials for 8V .....	11
Performance Data, 8V, 5-834MHz .....	12
Pin Configuration .....	17
Pin Description .....	17
Package Outline .....	18
Landing Pattern .....	19
Package Marking .....	20
Tape and Reel Information .....	20
Handling Precautions .....	21
Solderability .....	21
RoHS Compliance .....	21
Contact Information .....	21
Important Notice .....	22



### Absolute Maximum Ratings

Parameter	Rating
Supply Voltage (V <sub>DD</sub> )	+10 V
Supply Current (I <sub>DD</sub> )	400 mA
Maximum Input Level	+65 dBmV
Operating Temperature Range (Operating Device Heat Slug Temperature)	-40 to +100 °C
Storage Temperature Range	-65 to +150 °C
Maximum Junction Temperature	+150 °C

Exceeding any one or a combination of the Absolute Maximum Rating conditions may cause permanent damage to the device. Extended application of Absolute Maximum Rating conditions to the device may reduce device reliability.

### Electrical Specifications

Parameter	Condition (1)	Min	Typ	Max	Unit
Supply Voltage (V <sub>DD</sub> )			5/8		V
Supply Current (I <sub>DD</sub> )			250/350		mA
Frequency Range	5V and 8V operation	5		834	MHz
Gain			25		dB
Gain Slope			0.3		dB
Reverse Isolation			28		dB
Input Return Loss (5V)	5-700MHz		20		dB
Input Return Loss (5V)	700-834MHz		17		dB
Input Return Loss (8V)	5-834MHz		20		dB
Output Return Loss (5V)	5-700MHz		20		dB
Output Return Loss (5V)	700-834MHz		17		dB
Output Return Loss (8V)	5-834MHz		20		dB
Noise Figure	5-834MHz (2)		1.8/2.0		dB
CCN	At +64.5dBmV @ 5V and +67.5 @ 8V Total Composite Output Power. 57-729MHz, 113Ch, SC-QAM, 0dB tilt, 0dB offset (Source Corrected)		51		dB
OIP2L	+5 dBm / tone output, Δf=6MHz, Full Band		75/80		dBm
OIP2U	+5 dBm / tone output, Δf=6MHz, Full Band		68/73		dBm
OIP3	+5 dBm / tone output, Δf=6MHz, Full Band		42/45		dBm
OP1dB	5-834MHz		25.5/29.5		dBm
Thermal Resistance	ΘJC (Junction to Device Heat Slug)		12		°C/W

#### Notes:

- (1) Typical performance at these conditions: Temp = +25 °C, V<sub>DD</sub> = +5 V, 75 Ω system, Full band unless otherwise noted
- (2) Noise figure is 1.8 dB at 700MHz for 5V and 8V operation and 2.0 dB at 834MHz for 5V and 8V operation

### Evaluation Board Assembly Drawing

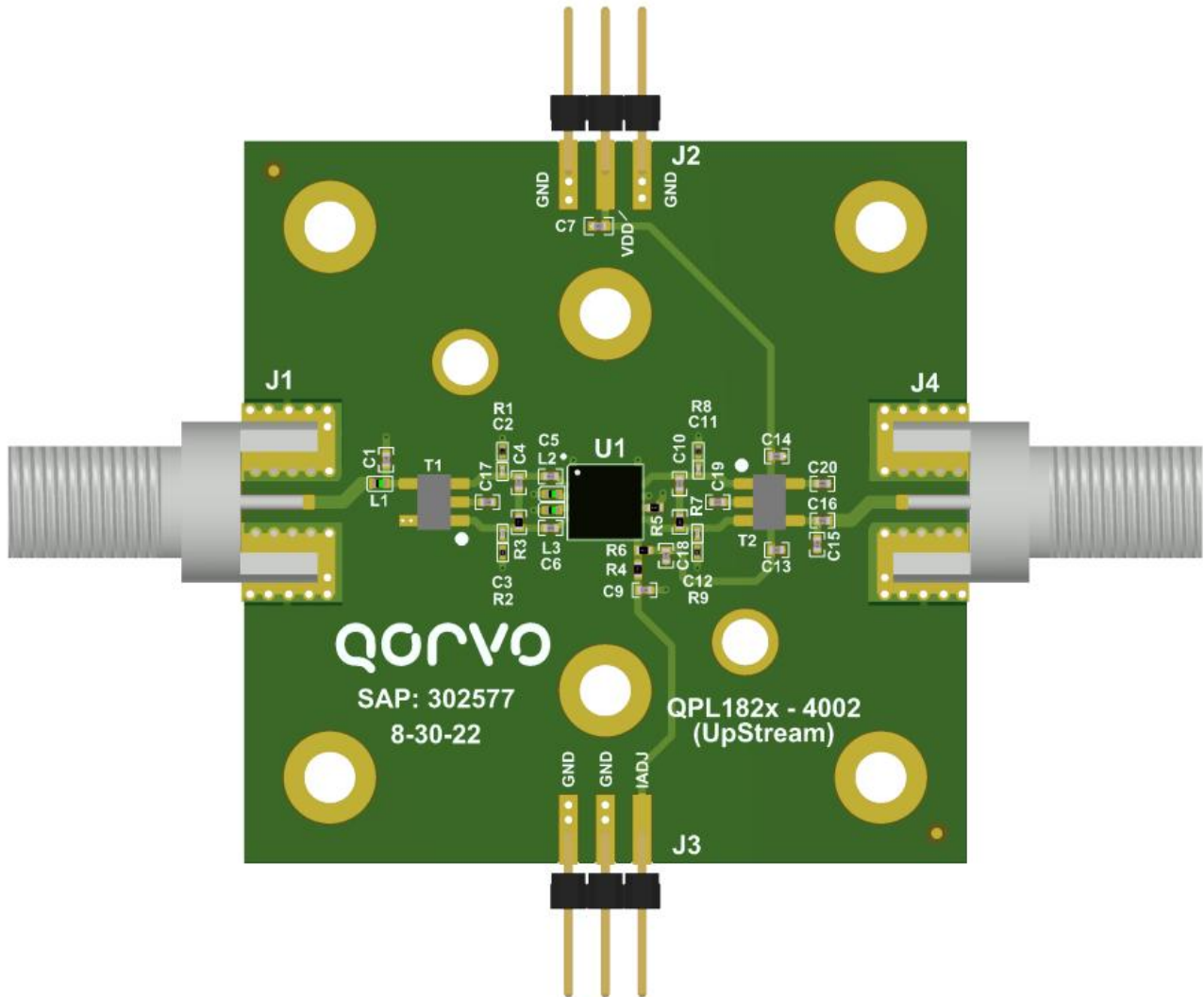

### LAYER STACK LEGEND

Material	Layer	Thickness	Dielectric Material	Type
	Top Overlay			Legend
Surface Material	Top Solder	0.0004in	SM-001	Solder Mask
CF-004	Top Layer	0.0007in		Signal
Core		0.0600in	FR4	Dielectric
CF-004	Bottom Layer	0.0007in		Signal
<b>Total thickness: 0.0618in</b>				

### Evaluation Board Schematic 5 – 834MHz, 5V

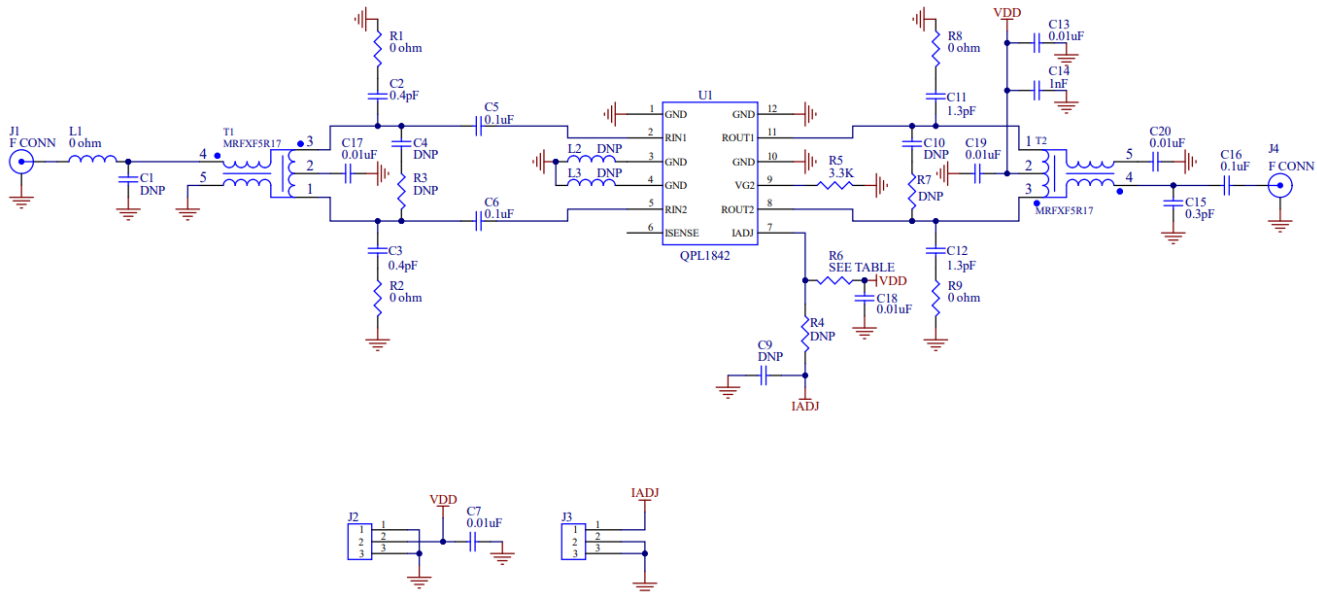

### Evaluation Board Bill of Materials for 5V

Ref Des	Description	Mfg Name	Mfg Part #
PCB	PCB, QPL1820	TTM Technologies	QPL1820-4002(A)
U1	834MHz, 5V, 25dB gain	Qorvo	QPL1842
C2,C3	CAP, 0.4pF, +/-0.1pF, 25V, HI-Q, 0201	Kamaya, Inc	RF03N0R4B250CT
C5,C6,C16	CAP, 0.1uF, 10%, 25V, X7R, 0402	MURATA	GRM155R71E104KE14D
C7,C13,C17, C18,C19,C20	CAP, 0.01uF, 10%, 50V, X7R, 0402	MURATA	GCM155R71H103KA55D
C11,C12	CAP, 1.3pF, +/-0.1pF, 25V, HI-Q, 0201	Kamaya, Inc	RF03N1R3B250CT
C14	CAP, 1000pF, 10%, 50V, X7R, 0402	MURATA	GRM155R71H102KA01D
C15	CAP, 0.3pF, +/-0.05pF, 50V, HI-Q, 0402	MURATA	GJM1555C1HR30WB01D
L1	RES, 0 OHM, 5%, 1/10W, 0402	Kamaya, Inc	RMC1/16SJPTH
R1,R2,R8,R9	010-0205-0000LF	Kamaya, Inc	RMC1/20JPPA
R5	RES, 3.3K OHM, 5%, 1/10W, 0402	Kamaya, Inc	RMC1/16S-332JTH
R6	RES, 820 OHM, 5%, 1/10W, 0402	Kamaya, Inc	RMC1/16S-821JTH
T1,T2	XFMR, BALUN, 1:1, 5-850MHz, 75 OHM	MiniRF, Inc.	MRFXF5R18
J2,J3	CONN, HDR, ST, 4-PIN, 0.100"	SAMTEC INC	TSW-103-07-G-S
J1,J4	CONN, F FEM EDGE MOUNT, 75 OHMS, 0.068"	Millimeter Wave Alpha Nova Tech Inc	MW-846-C-DD-75
Heatsink	50 x 50 x10, ALUMINUM		S08EFV05-A
C1,C4,C9,C10,R3,R4, R7,L2,L3	NOT POPULATED ITEM		DUMMY PART

### Performance Data, 5V @ 250mA; 5MHz-834MHz

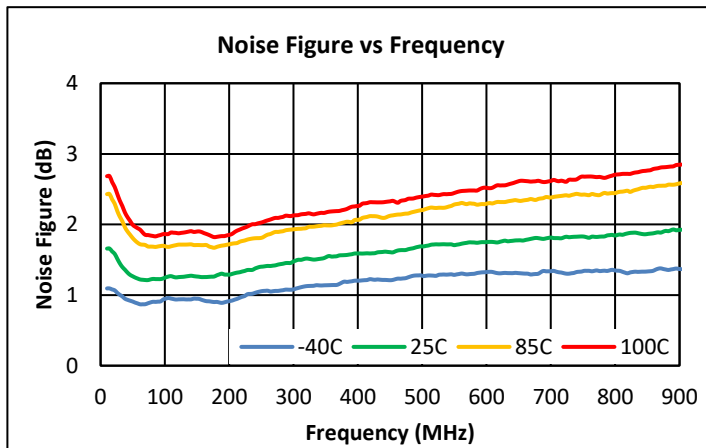
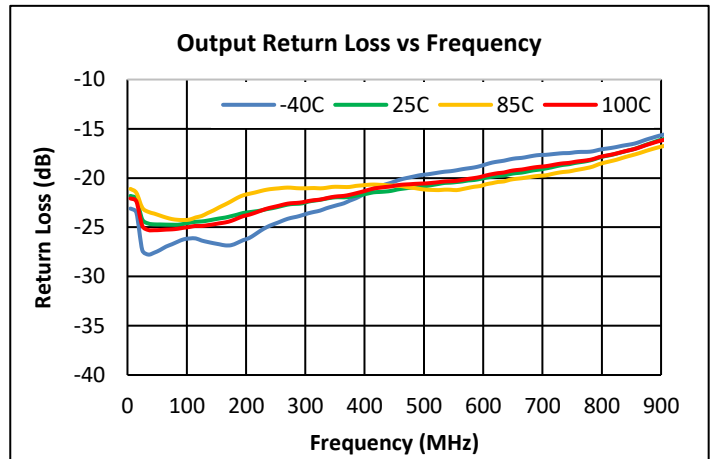
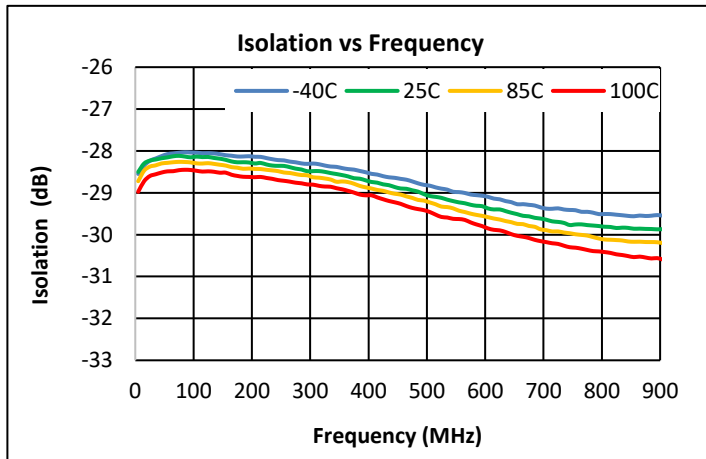
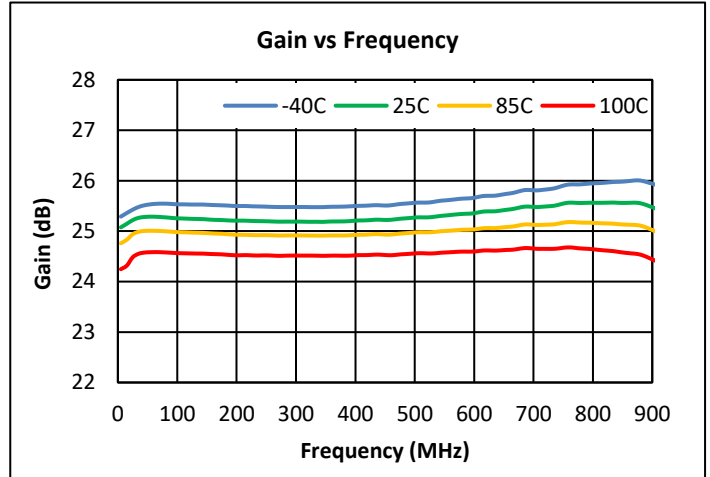
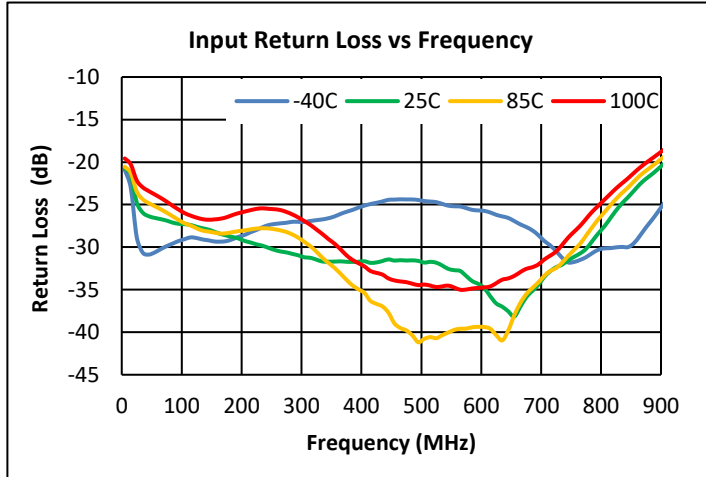

### Performance Data, 5V @ 250mA, (Cont'd); 5MHz-834MHz

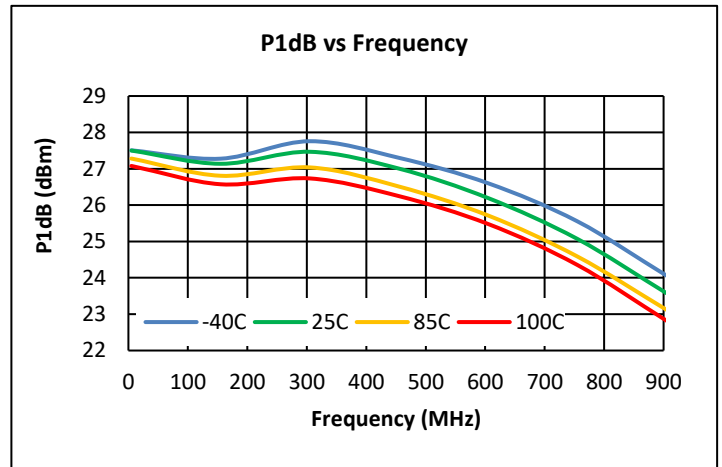
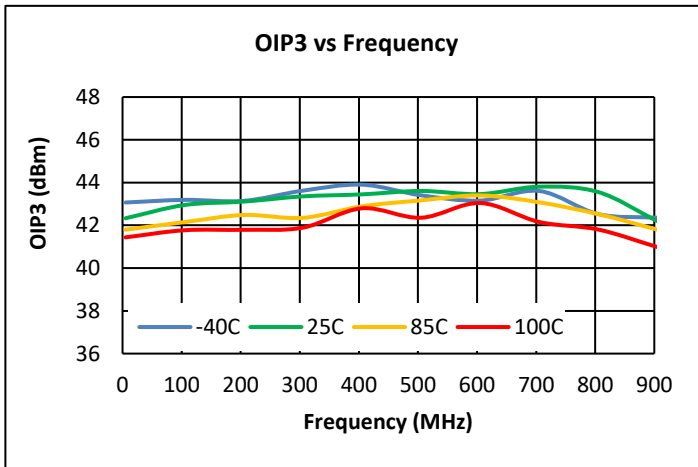
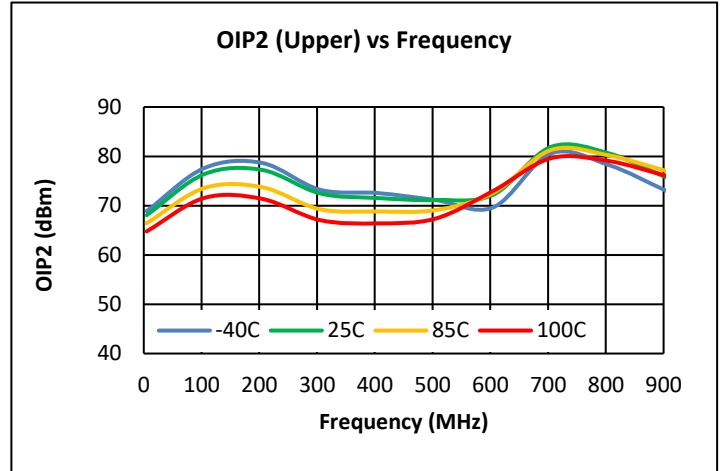
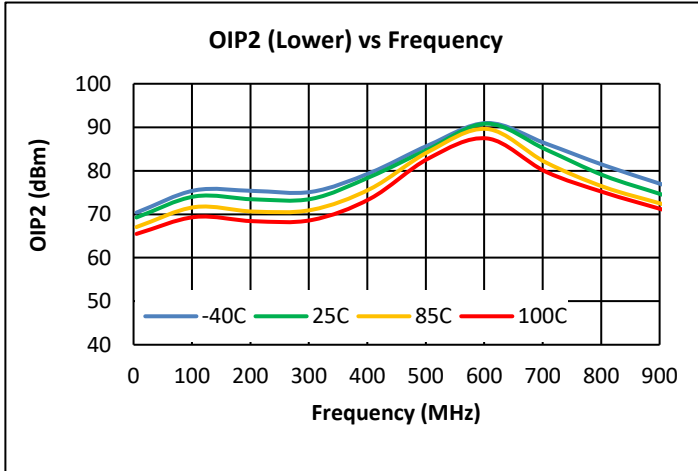

**Notes:**

- (1) 5V OIP2: +5dBm/ tone output @  $\Delta f = 6\text{MHz}$
- (2) 5V OIP3: +5dBm/ tone output @  $\Delta f = 6\text{MHz}$

### Performance Data, 5V @ 250mA, (Cont'd); 5MHz-834MHz

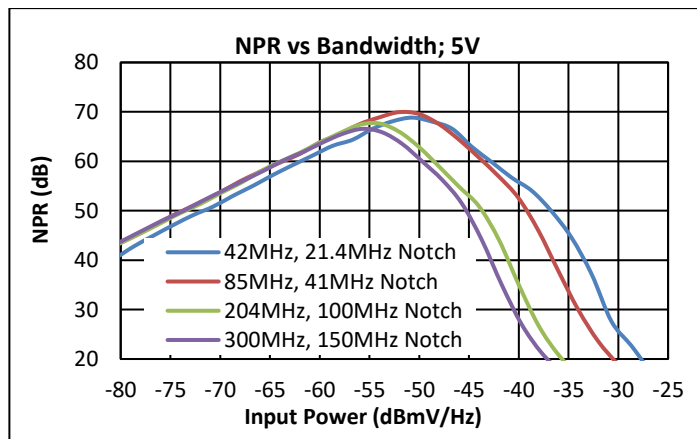
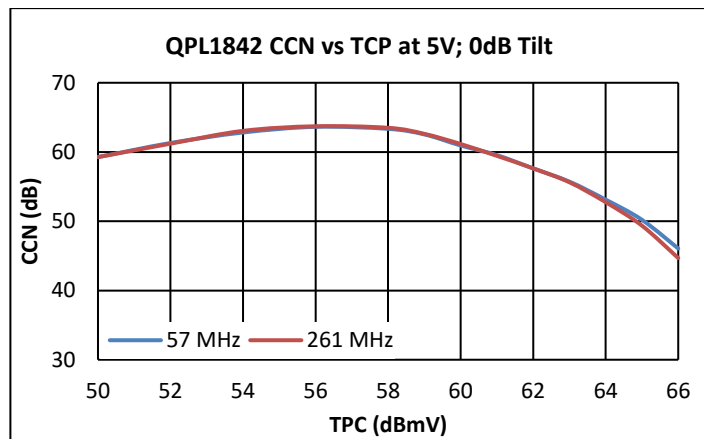
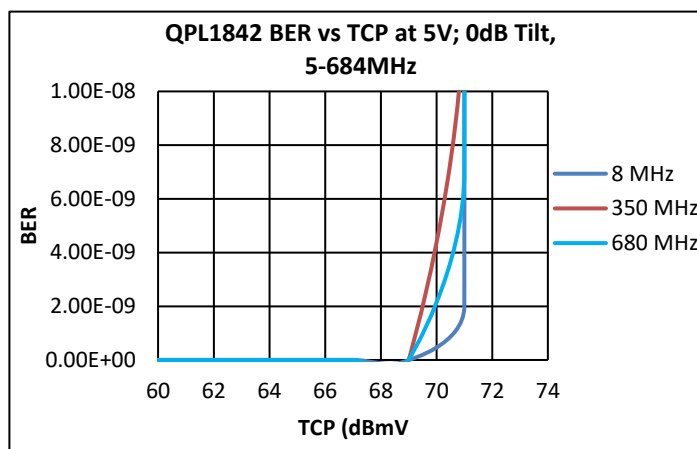
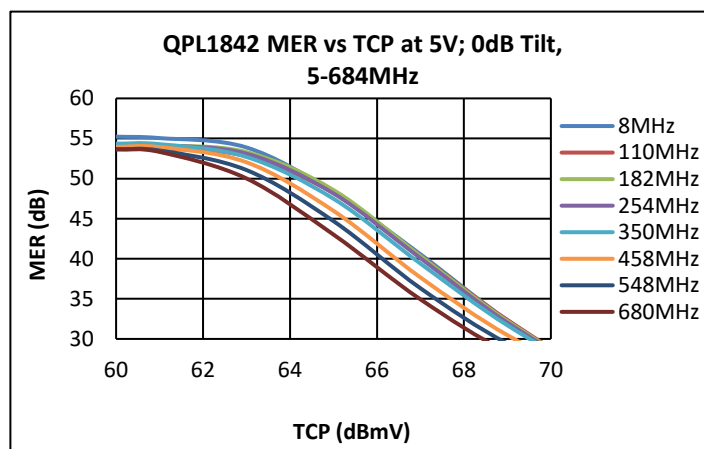
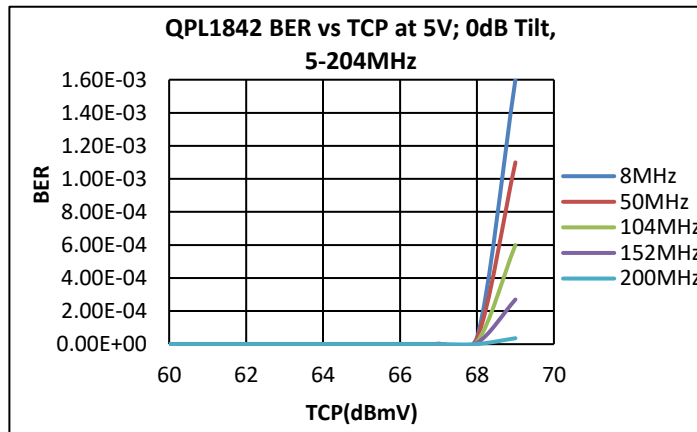
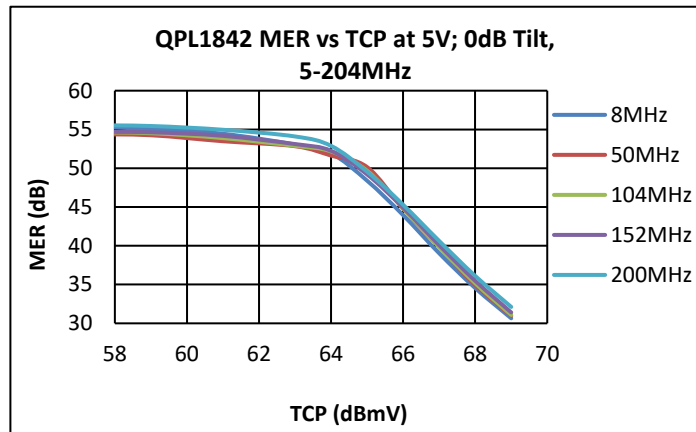

**Notes:**

- (1) BER & MER Test Conditions: 5-204MHz & 5-684MHz, 111 Ch. SC-QAM, 0dB tilt
- (2) CCN Test conditions: 57-885MHz, 138Ch, SC-QAM, 0dB tilt, 0dB offset

### Performance Data vs Bias Supply, 5V; 5MHz-834MHz

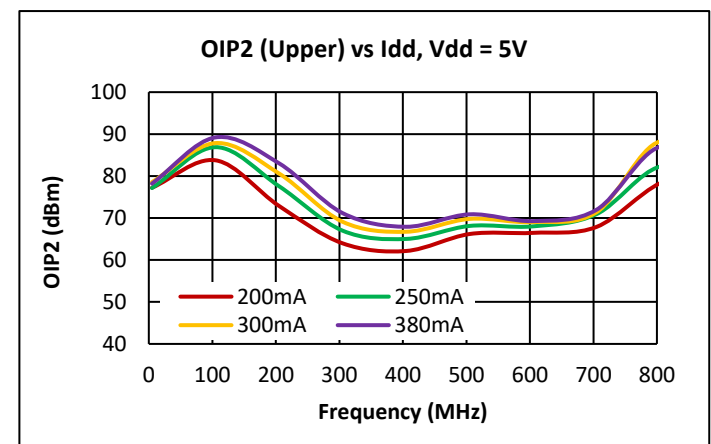
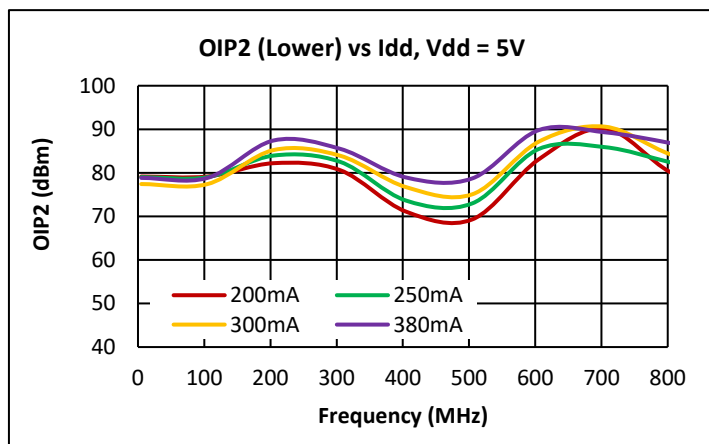
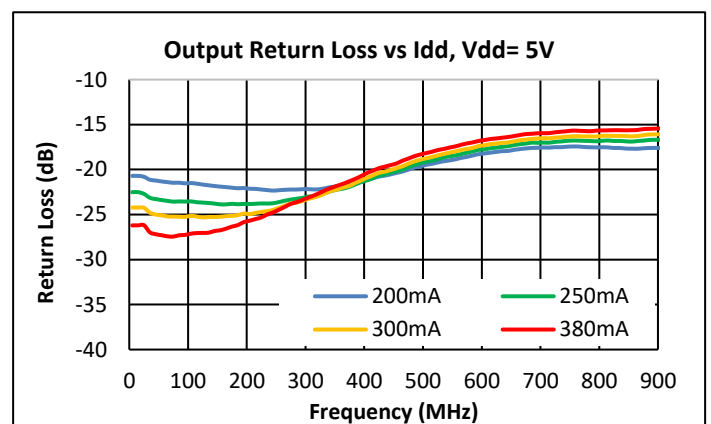
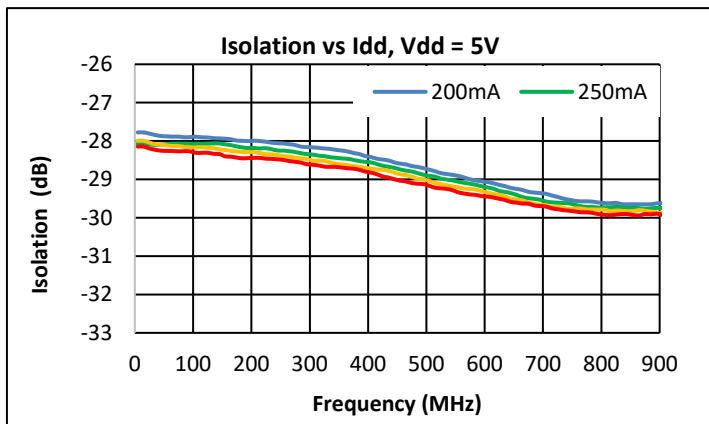
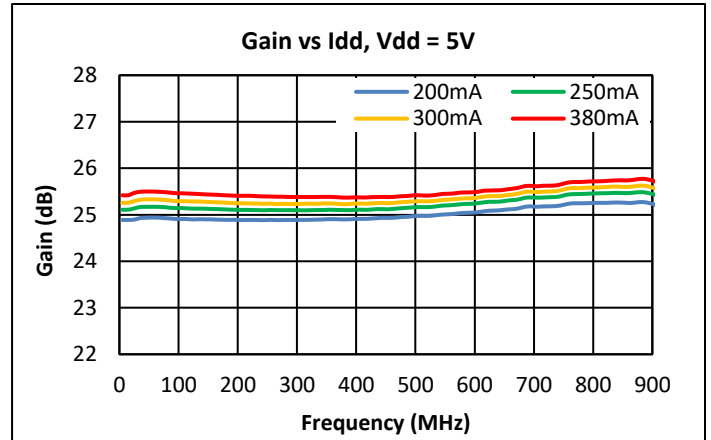
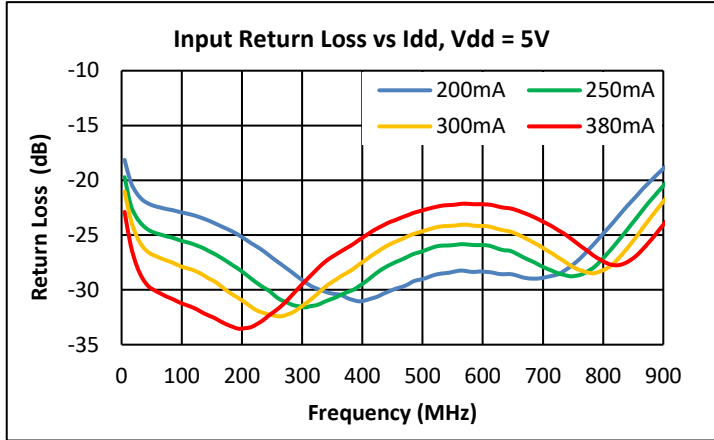

**Notes:**

(1) 5V OIP2: +5dBm / tone output @ Δf = 6MHz

### Performance Data vs Bias Supply, 5V, (Cont'd); 5MHz-834MHz

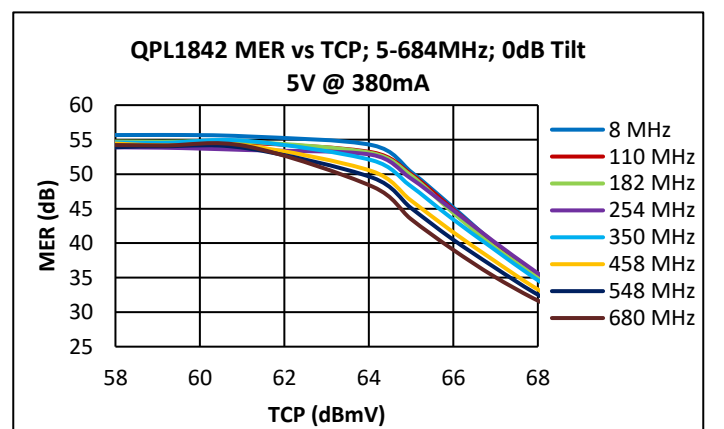
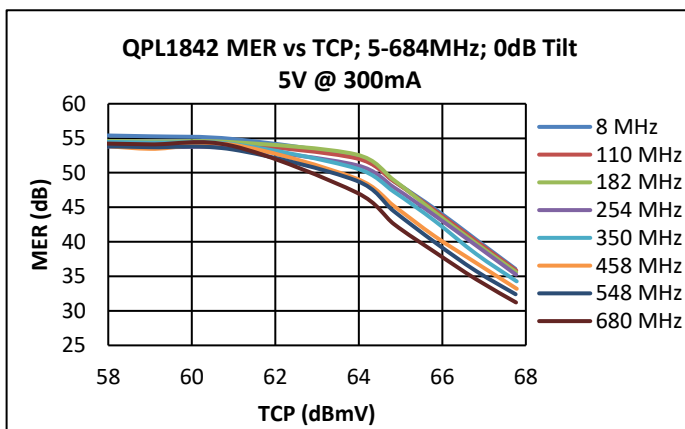
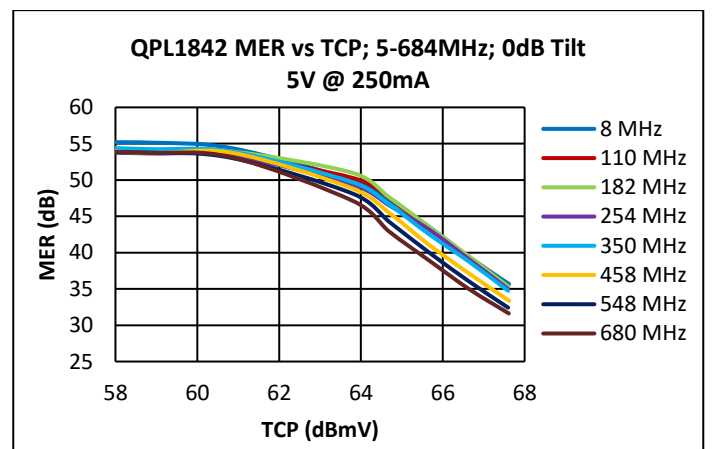
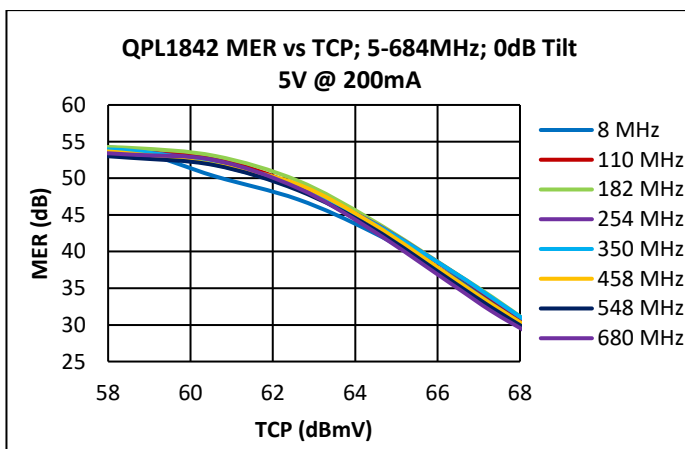
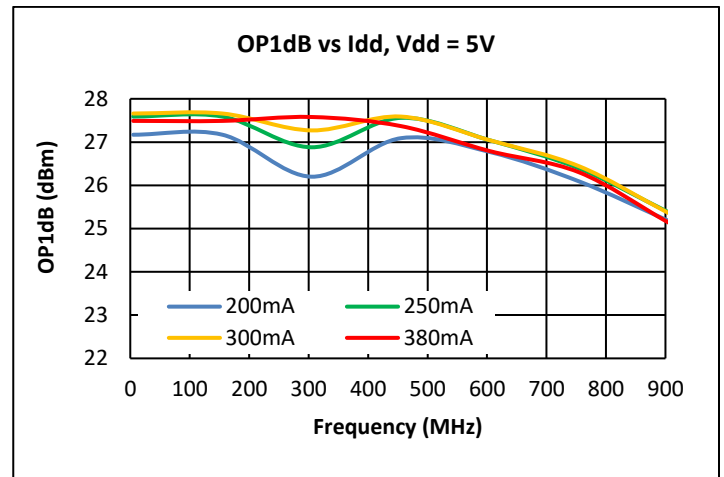
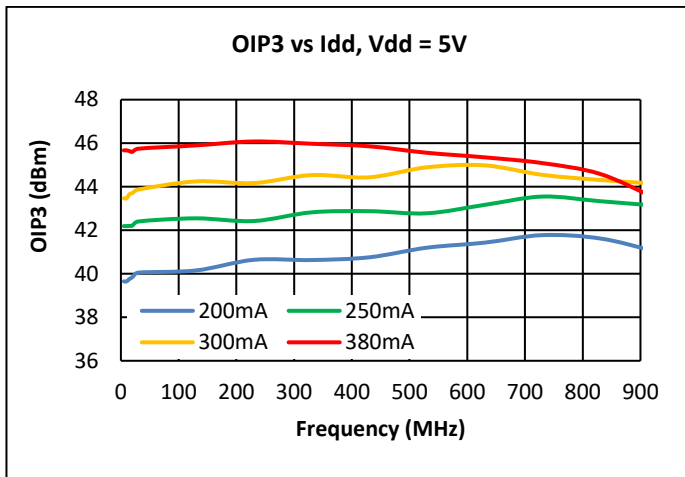

**Notes:**

- (1) 5V OIP3: +5dBm/ tone output @ Δf = 6MHz

### Evaluation Board Schematic; 5 – 834MHz, 8V

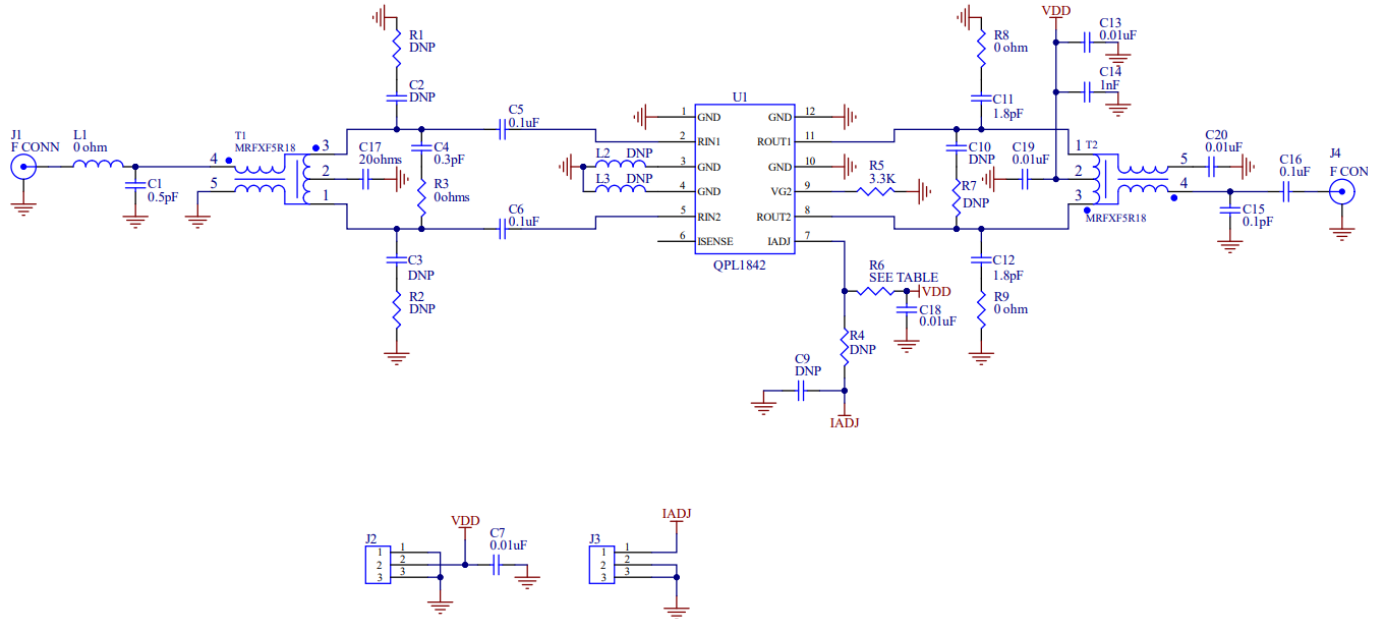

### Evaluation Board Bill of Materials for 8V

Ref Des	Description	Mfg Name	Mfg Part #
PCB	PCB, QPL1820	TTM Technologies	QPL182x-4002(A)
U1	834MHz, 8V, 25dB gain	Qorvo	QPL1842
C1	CAP, 0.5pF, +/-0.25pF, 50V, HI-Q, 0402	Murata	GJM1555C1HR50CB01D
C4	CAP, 0.3pF, +/-0.1pF, 50V, HI-Q, 0402	Murata	GJM1555C1HR30BB01D
C5, C6, C16	CAP, 0.1uF, 10%, 25V, X7R, 0402	Murata	GRM155R71E104KE14D
C7, C13, C18, C19, C20	CAP, 0.01uF, 10%, 50V, X7R, 0402	Murata	GCM155R71H103KA55D
C11, C12	CAP, 1.8pF, +/-0.25pF, 25V, HI-Q, 0201	Murata	GJM0335C1E1R8CB01D
C14	CAP, 1000pF, 10%, 50V, X7R, 0402	Murata	GRM155R71H102KA01D
C15	CAP, 0.1pF, +/-0.05pF, 50V, HI-Q, 0402	Murata	GJM1555C1HR10WB01D
C17	RES, 20 OHM, 5%, 1/10W, 0402	Panasonic	ERJ-2GEJ200X
L1	IND, 2.7nH, +/-0.3nH, M/L, 0402	Murata	LQG15HN2N7S02D
R3	RES, 0 OHM, JUMPER, 0402	Kamaya	RMC1/16SJPTH
R8, R9	RES, 0 OHM, JUMPER, 0201	Kamaya	010-0205-0000LF
R5	RES, 3.3K OHM, 5%, 1/10W, 0402	Kamaya	RMC1/16S-332JTH
R6	RES, 1.3K OHM, 5%, 1/10W, 0402	Kamaya	ERJ-2GEJ132X
T1, T2	XFMR, BALUN, 1:1, 5-850MHz, 75 OHM	MiniRF	MRFXF5R18
J2, J3	CONN, HDR, ST, 4-PIN, 0.100"	SAMTEC INC	TSW-103-07-G-S
J1, J4	CONN, F FEM EDGE MOUNT, 75 OHMS, 0.068"	MillimeterWave	MW-846-C-DD-75
Heatsink	50 x 50 x10, ALUMINUM	Alpha Nova Tech Inc	S08EFV05-A
C2, C3, C9, C10, L2, L3, R1, R2, R4, R7	Not Populated Item		Dummy Part

### Performance Data, 8V @ 350mA; 5MHz-834MHz

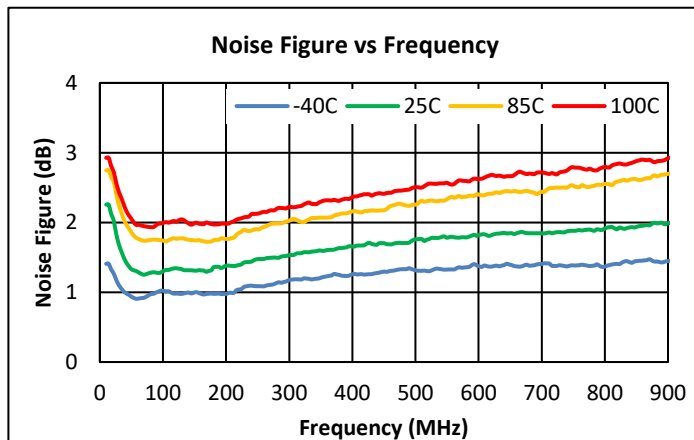
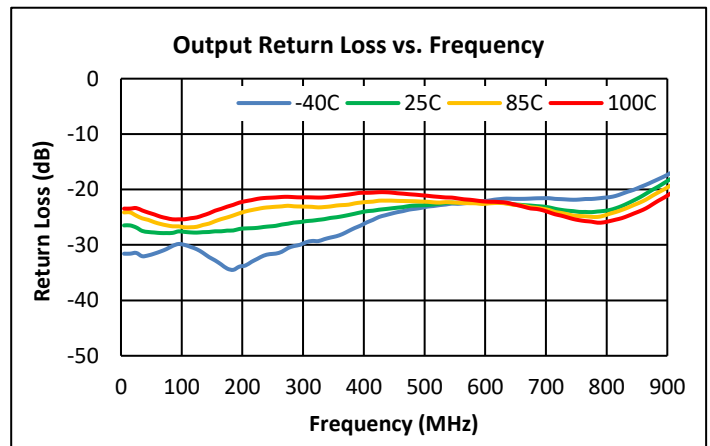
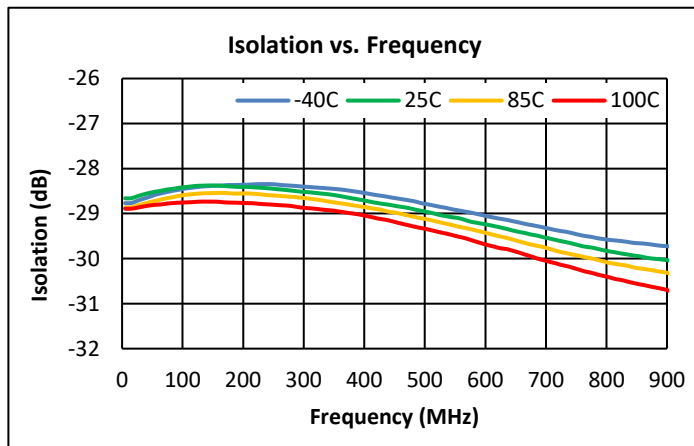
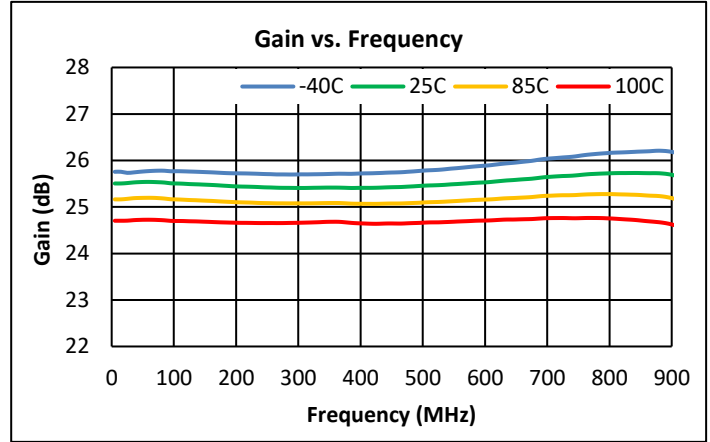
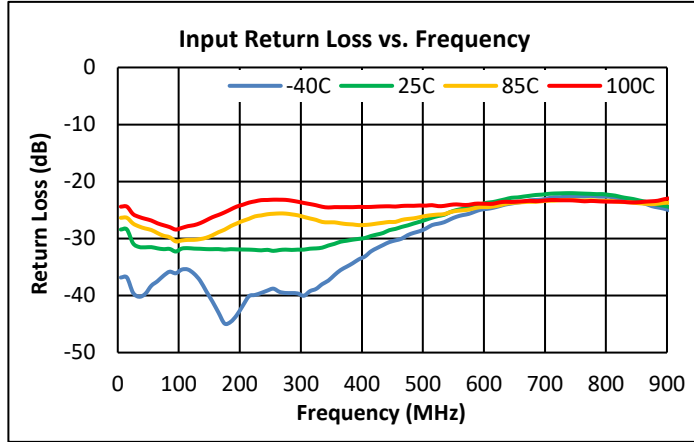

### Performance Data, 8V @ 350mA, (Cont'd); 5MHz-834MHz

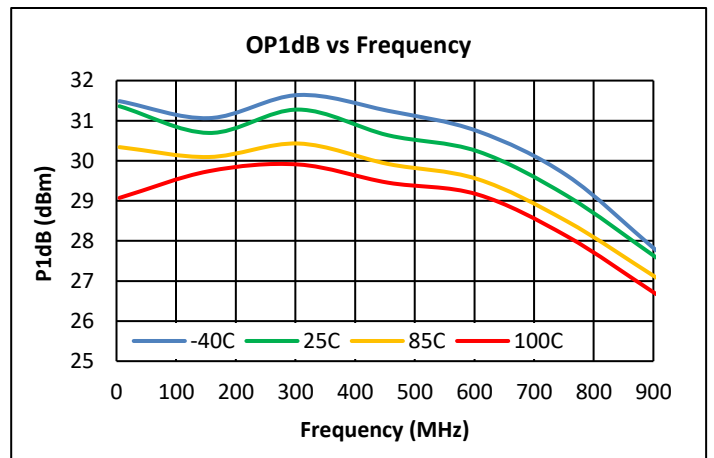
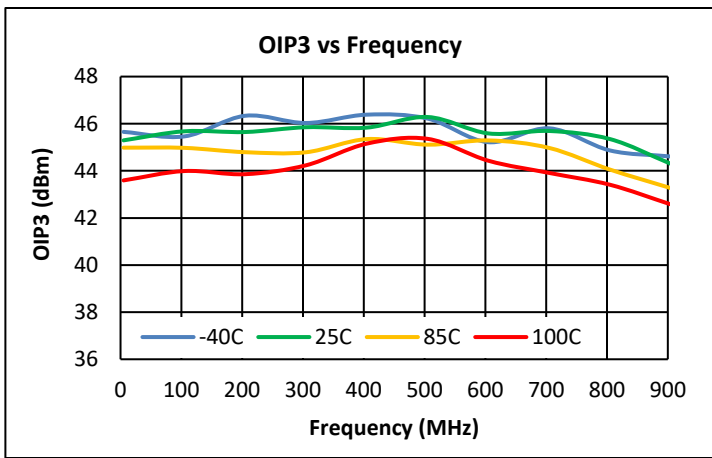
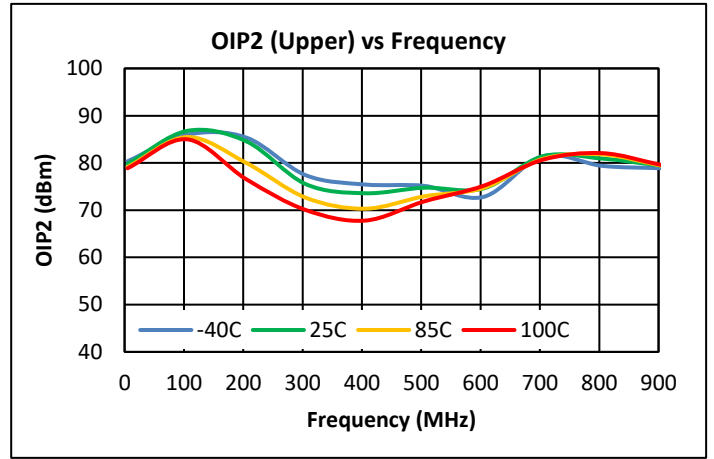
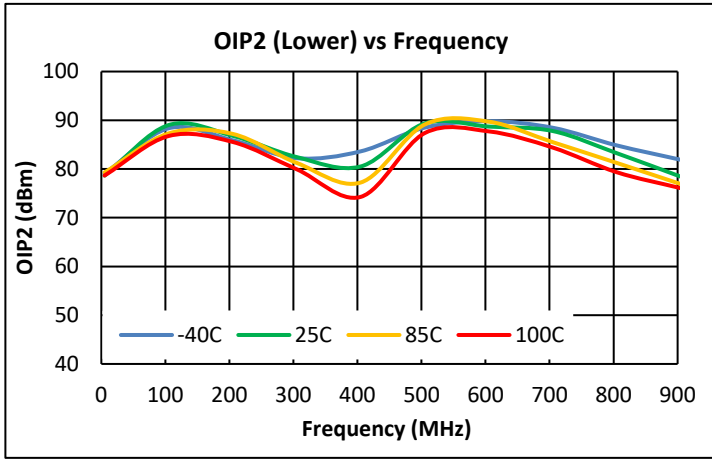

**Notes:**

- (1) 8V OIP2: +5dBm/tone output @ Δf = 6MHz
- (2) 8V OIP3: +5dBm/tone output @ Δf = 6MHz

### Performance Data, 8V @ 350mA (Cont'd); 5MHz-834MHz

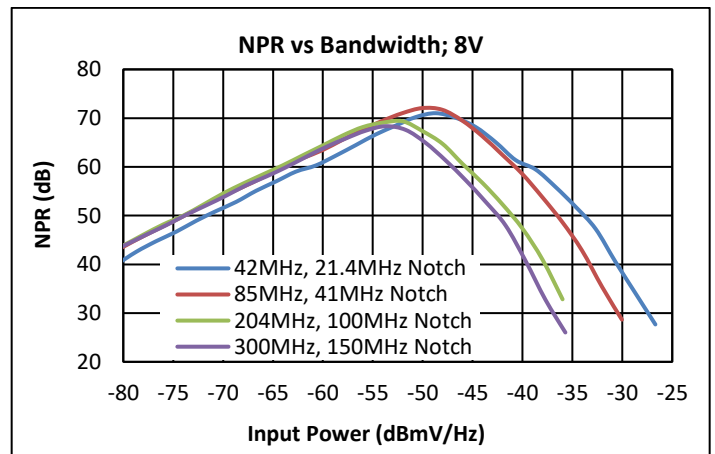
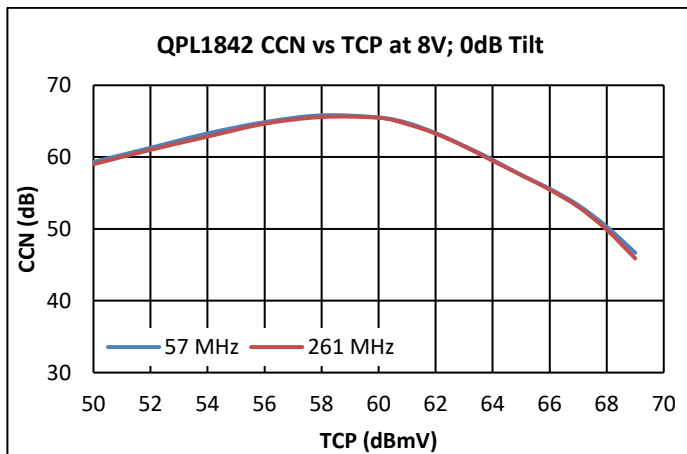
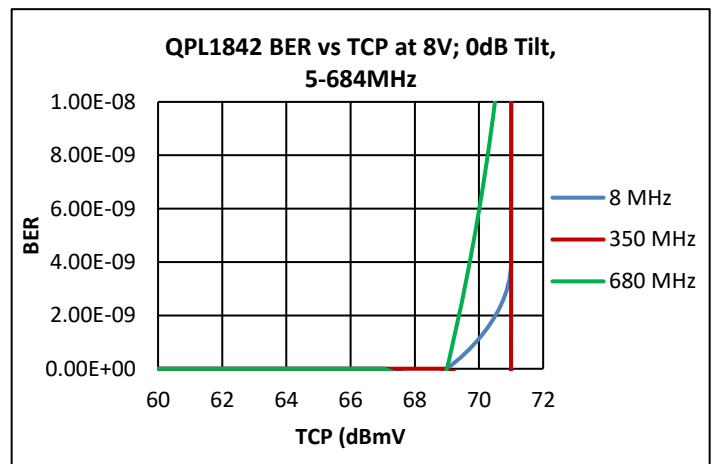
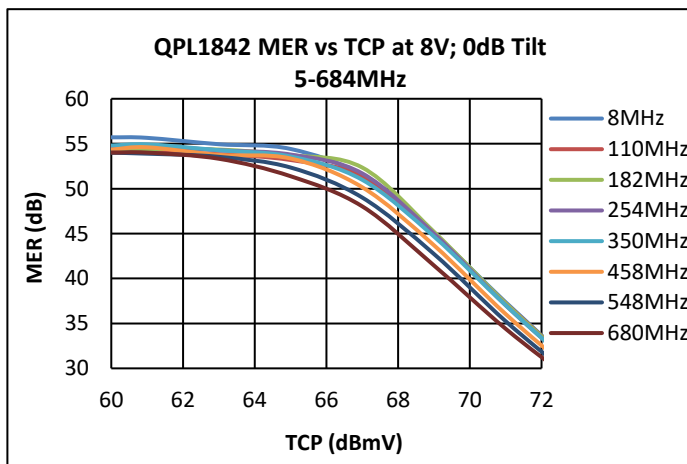
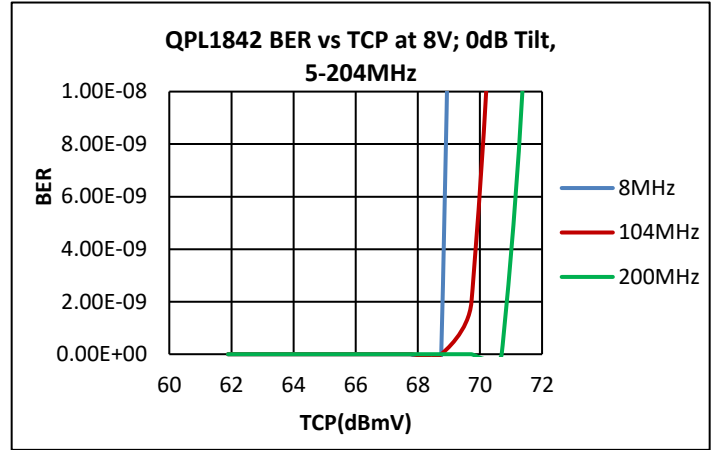
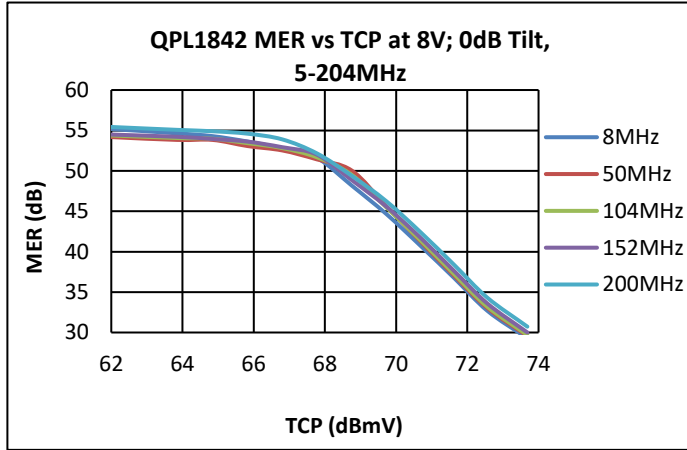

**Notes:**

- 1) BER & MER Test Conditions: 5-204MHz & 5-684MHz, 111 Ch. SC-QAM, 0dB tilt
- 2) CCN Test Conditions: 57-885MHz; 138Ch, SC-QAM, 0dB tilt, 0dB offset

### Performance Data vs Bias Supply, 8V; 5MHz-834MHz

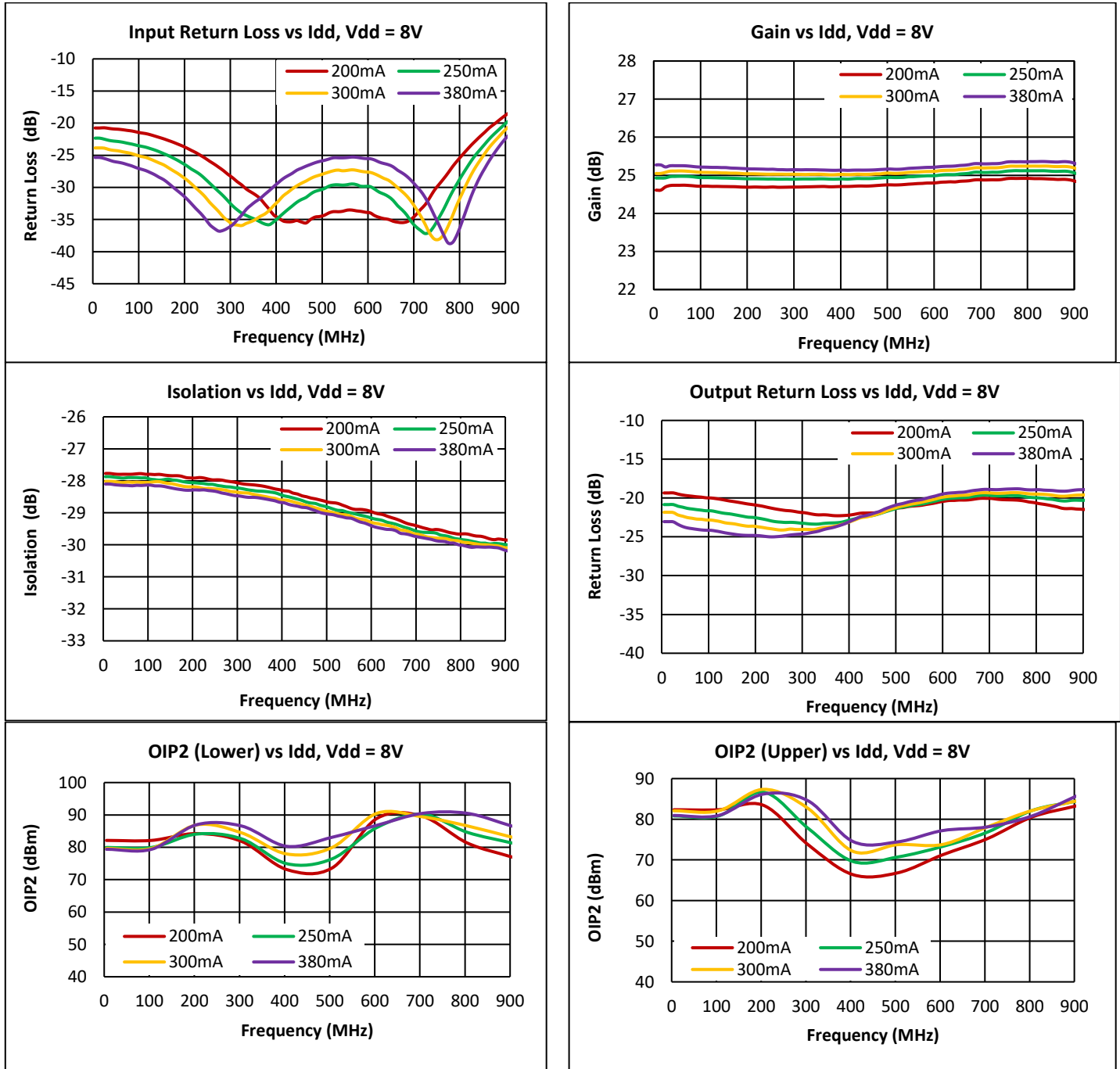

**Notes:**

- (1) 8V OIP2: +5dBm/ tone output @ Δf = 6MHz

### Performance Data vs Bias Supply, 8V (Cont'd); 5MHz-834MHz

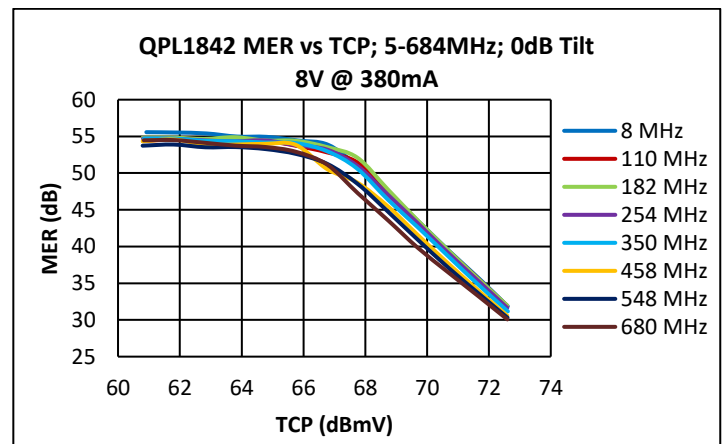
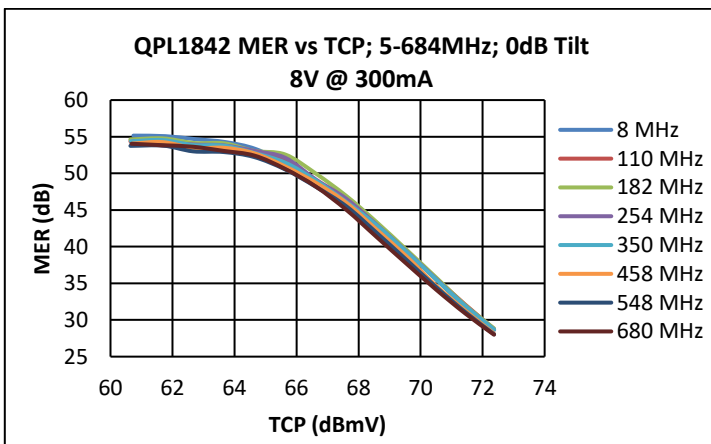
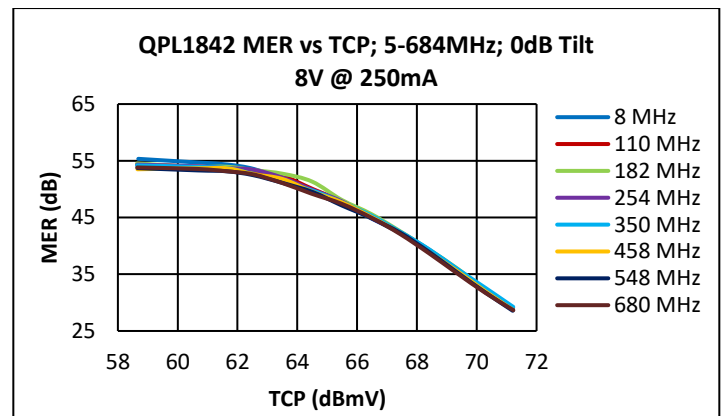
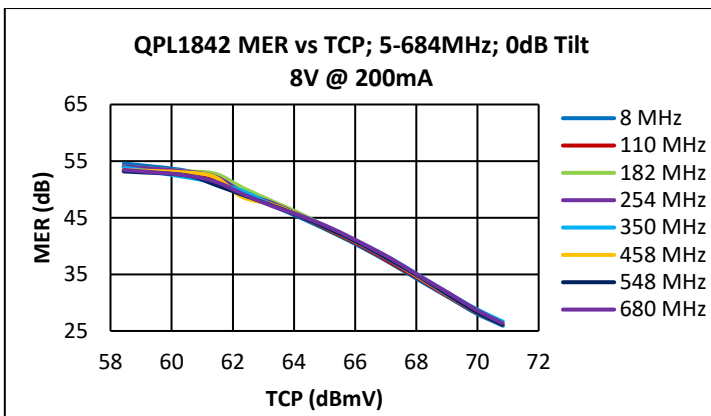
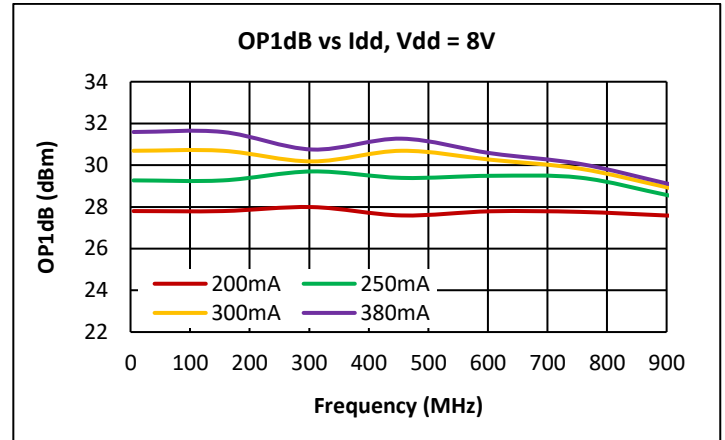
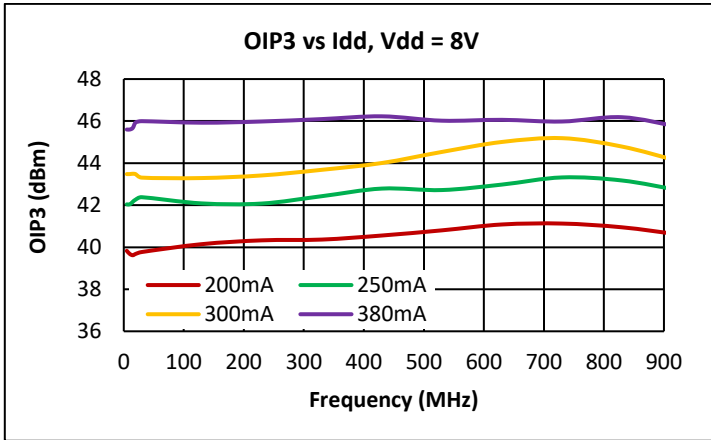

**Notes:**

(1) 8V OIP3: +5dBm/ tone output @ Δf = 6MHz

### Pin Configuration

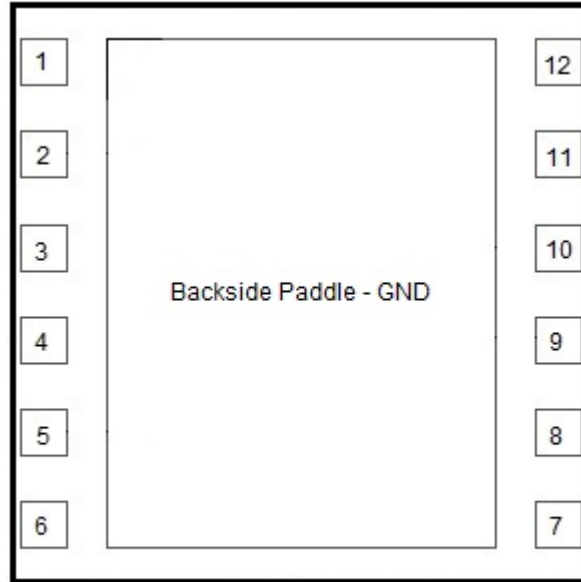

### Pin Description

Pin Number	Label	Description
1	NC	No internal connection, recommend connecting to EVB GND
2	RFIN+	RF Input +
3	GND	Must be connected to EVB GND
4	GND	Must be connected to EVB GND
5	RFIN-	RF input -
6	NC	No connect pin. Leave it open. Do not connect to GND.
7	IADJ	IDD current set
8	RFOUT-/VDD2	RF output - and VDD through RF Choke
9	VG2	Cascode device bias resistor divider
10	NC	No internal connection, recommend connecting to EVB GND
11	RFOUT+/VDD	RF output + and VDD through RF Choke
12	NC	No internal connection, recommend connecting to EVB GND
Paddle	GND	DC/RF/Thermal/GND. (Maximize vias in this area)

### Package Outline

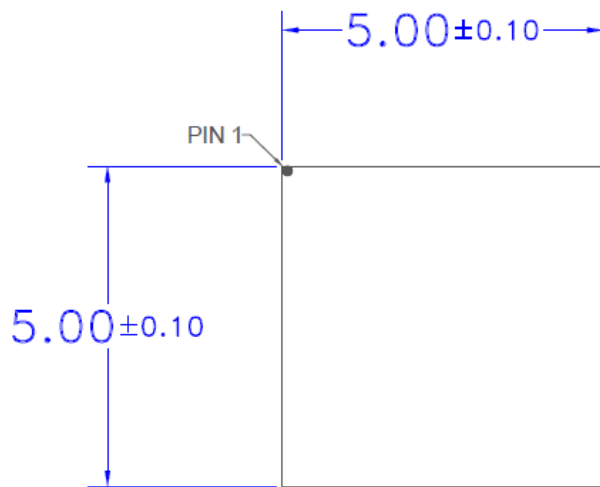

TOP  
VIEW

0.920 ± 0.060



SIDE  
VIEW

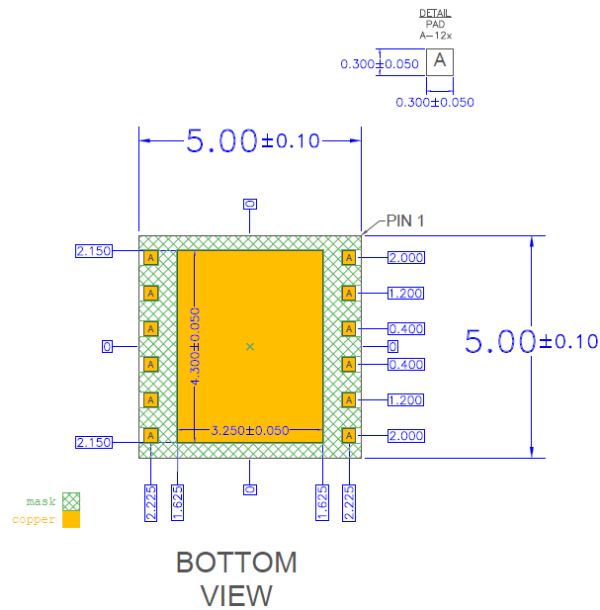

BOTTOM  
VIEW



### Package Marking

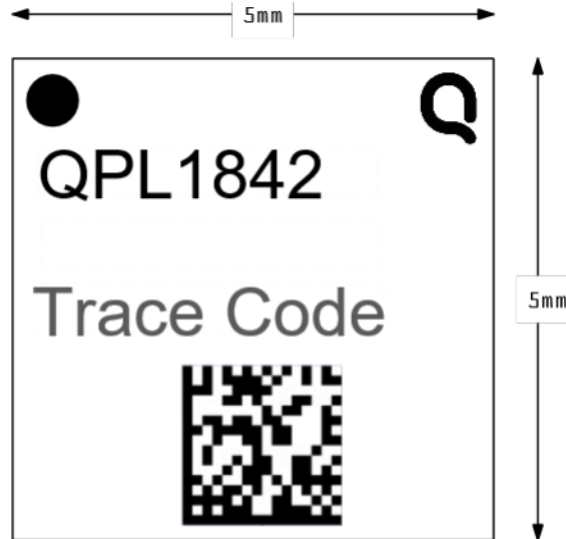

- Pin 1 Indicator
- Qorvo Logo - Use Q5D
- Trace Code to be assigned by SubCon
- 2D Matrix

### Tape and Reel Information

Qorvo Part Number	Reel Diameter Inch (mm)	Hub Diameter Inch (mm)	Width (mm)	Pocket Pitch (mm)	Feed	Units Per Reel
QPL1842 TR13	13 (330)	4 (102)	12	8	Single	2500

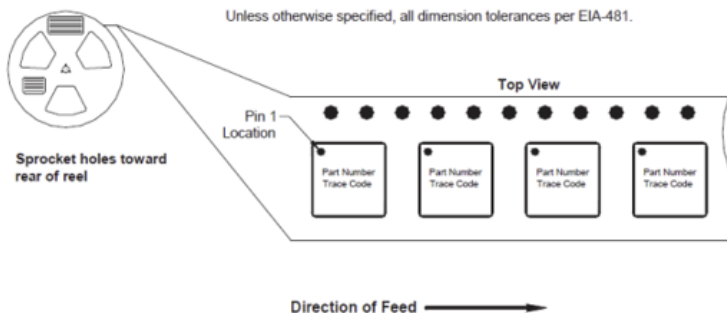



Figure 1: 5.000 mm x 5.000 mm (Carrier Tape Drawing with Part Orientation)

### Handling Precautions

Parameter	Rating	Standard	 Caution! ESD Sensitive Device
ESD – Human Body Model (HBM)	Class 1C (1000V to <2000V)	ANSI / ESDA / JEDEC JS-001	
ESD – Charged Device Model (CDM)	Class C3 (≥ 1000V)	ANSI / ESDA / JEDEC JS-002	
MSL – Moisture Sensitivity Level	MSL3	IPC / JEDEC J-STD-020	

### Solderability

Compatible with both lead-free (260 °C max. reflow temp.) and tin / lead (245 °C max. reflow temp.) soldering processes. Solder profiles available upon request.

Contact plating: ENEPIG

### RoHS Compliance

This part is compliant with 2011/65/EU RoHS directive (Restrictions on the Use of Certain Hazardous Substances in Electrical and Electronic Equipment) as amended by Directive 2015/863/EU.

This product also has the following attributes:

- PFOS Free
- Halogen Free (Chlorine, Bromine)
- Antimony Free
- TBBP-A (C<sub>15</sub>H<sub>12</sub>Br<sub>4</sub>O<sub>2</sub>) Free
- SVHC Free

### Contact Information

For the latest specifications, additional product information, worldwide sales and distribution locations:

**Tel:** 1-844-890-8163

**Web:** [www.qorvo.com](http://www.qorvo.com)

**Email:** [customer.support@qorvo.com](mailto:customer.support@qorvo.com)



**QPL1842**

**75  $\Omega$  25 dB CATV Amplifier (5 – 834MHz)**

## Important Notice

---

The information contained herein is believed to be reliable; however, Qorvo makes no warranties regarding the information contained herein and assumes no responsibility or liability whatsoever for the use of the information contained herein. All information contained herein is subject to change without notice. Customers should obtain and verify the latest relevant information before placing orders for Qorvo products. The information contained herein or any use of such information does not grant, explicitly or implicitly, to any party any patent rights, licenses, or any other intellectual property rights, whether with regard to such information itself or anything described by such information. **THIS INFORMATION DOES NOT CONSTITUTE A WARRANTY WITH RESPECT TO THE PRODUCTS DESCRIBED HEREIN, AND QORVO HEREBY DISCLAIMS ANY AND ALL WARRANTIES WITH RESPECT TO SUCH PRODUCTS WHETHER EXPRESS OR IMPLIED BY LAW, COURSE OF DEALING, COURSE OF PERFORMANCE, USAGE OF TRADE OR OTHERWISE, INCLUDING THE IMPLIED WARRANTIES OF MERCHANTABILITY AND FITNESS FOR A PARTICULAR PURPOSE.**

Without limiting the generality of the foregoing, Qorvo products are not warranted or authorized for use as critical components in medical, life-saving, or life-sustaining applications, or other applications where a failure would reasonably be expected to cause severe personal injury or death.

Copyright 2026 © Qorvo, Inc. | Qorvo is a registered trademark of Qorvo, Inc.