

Mid-Band Low-Band NB-IoT TxM

Product Overview

QM55003 is a hybrid, multi-band multi-chip RF front-end (RFFE) module supporting for NB-IoT and Cat-M1 application. The module supports LB and MB and NTN Operation. It has integrated harmonic rejection LPF, antenna switch and auxillary TX/RX path. QM55003 band select and bias are programmed through a Mobile Industry Processor Interface (MIPI).

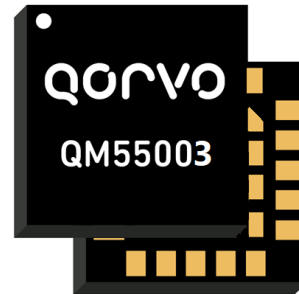

Package: Module, 20-Pin 4.00 x 4.00 x 0.64 mm

Functional Block Diagram

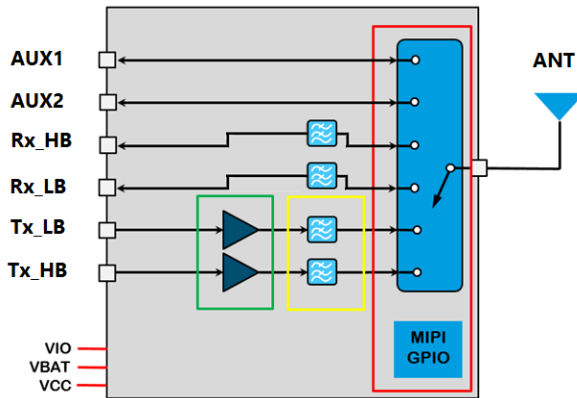

Functional Block Diagram

Key Features

- Integrated Switch Supports Multiple TX and RX
- MIPI RFFE Digital Control Interface
- Integrated harmonic reject LPF
- Integrated Rx LPF for out-of-band rejection
- NTN Operation Bands: 23, 24, 255, 256
- AUX paths
- 2.5V supplies
- Optimized use with DC/DC Converter Operation
- Average Power Tracking
- Optimized for Narrow-Band IoT and Cat-M1
- Programmable Bias Level Control

Ordering Information

Part Number	Description
QM55003PCK	Evaluation Board Sample Kit
QM55003SB	5-Piece Sample Bag
QM55003SQ	25-Piece Sample Bag
QM55003SR	100-Piece 7inch Sample Reel
QM55003TR13	5000-Piece 13inch Reel
QM55003DK	Design Kit: QM55003PCK +RD2000 Communication Board

Applications

- LTE mid-bands: 1, 2, 3, 4, 25, 39, 66, 70, 107
- LTE low-bands: 5, 8, 12, 13, 14, 17, 18, 19, 20, 26, 27, 28, 71, 85
- NTN Operation Bands: 23, 24, 255, 256
- Narrow-Band IoT and Cat-M1

Absolute Maximum Ratings

Parameter	Conditions	Rating
Supply Voltage, VCC	Standby, Idle, Operating Mode	6V
Supply Voltage, Vbatt	Standby, Idle, Operating Mode	6V
VIO and Digital control signals (SCLK, SDATA)		2.0 V
RF Input Power		10dBm
Output Load VSWR (Ruggedness)	Ruggedness is guaranteed with open loop condition, Pin adjusted for Pout = Max Prated into 50Ω load, Vcc = Vbat = 4.5V, over temperature	20:1
Operating Temperature		-40 to +105 °C
Storage Temperature		-50 to 150 °C
ESD	HBM	1500V
ESD	CDM	1000V

Exceeding any one or a combination of the Absolute Maximum Rating conditions may cause permanent damage to the device. Extended application of the Absolute Maximum Rating conditions to the device may reduce device reliability. Specified typical performance or functional operation of the device under Absolute Maximum Rating conditions is not implied.

Recommended Operating Conditions

Parameter	Min.	Typ.	Max.	Units
Supply Voltage, Vbatt	1.8	3.0	4.5	V
Supply Voltage, Vcc	0.5 ⁽¹⁾	2.5	4.5	V
Supply Voltage, VIO	1.65	1.8	1.95	V
MIPI RFFE logic low (SCLK,SDATA)	0		0.3*VIO	V
MIPI RFFE logic high (SCLK,SDATA)	0.7*VIO		VIO	V
Leakage Current	0	0.3	3 ⁽²⁾	uA
VIO Rise Time (required for device reset)	0		400	us
Operating Ambient Temperature	-40	25	+85	°C

Note 1: Vcc down to 0.5V may be used for backed-off power when using DC/DC converter to reduce low power current drain. Refer to Look-up Table (LUT, supplied separately) for recommended Vcc settings for each output power level.

Note 2: Device in Power Down Mode, VIO = 1.8V, Vbatt = 3.0V, Vcc = 2.5V.

Power vs NB-IoT Modulation Table

ID	Modulation	Subcarrier Spacing (KHz)	Number of Tones	Tone Positions	MPR (dB)	Rated Pout (dBm)
1tone@positon0	QPSK	15	1	0	0	24
3tone@position0..2		15	3	0..2	0.5	23.5
3tone@position3..5		15	3	3..5	0	24
3tone@position9..11		15	3	9..11	0.5	23.5
6tone@position0..5		15	6	0..5	1	23
6tone@position6..11		15	6	6..11	1	23
12tone@position0..11		15	12	0..11	2	22
1tone@positon0		BPSK	3.75	1	0	0
1tone@positon47	3.75		1	47	0	24

Electrical Specifications: NB-IoT : Band 1, 2, 3, 4, 25, 66, 70

(Temp = +25°C, Vbatt =3.0V, VCC = 2.5V, VIO= +1.8V, 50 Ω system, Modulation used: QPSK 1tone@position0, 15 KHz subcarrier spacing, 1 tone with MPR=0, unless otherwise specified.)

Parameter	Conditions	Min.	Typ.	Max.	Units	
Frequency Range	Band 1	1920	1950	1980	MHz	
	Band 2, 25	1850	1882.5	1915		
	Band 3, 66	1710	1747.5	1785		
	Band 4	1710	1732.5	1755		
	Band 70	1695	1702.5	1710		
Maximum Linear Output Power	HPM	24	-	-	dBm	
Gain	Band 1	-	27	-	dB	
	Bands 2, 25	-	27	-		
	Bands 3, 4, 66, 70	-	28	-		
GSM ACLR	Bands 3, 4, 66, 70	HPM, Prated – 2dB (MPR), Vcc = 2.5V, Modulation = QPSK 12tone@positon0..11, 15 KHz SC	-	-45	-29	dBc
	Band 1		-	-42		
	Bands 2, 25		-	-44		
UTRA ACLR			-	-64	-46	
PA Total Current	Bands 3, 4, 66, 70	HPM, Pout = Prated	-	347	-	mA
	Band 1		-	386	-	
	Bands 2, 25		-	375	-	
PAE	Bands 3, 4, 66, 70	HPM, Pout = Prated	-	29	-	%
	Band 1		-	26	-	
	Bands 2, 25		-	27	-	
EVM	HPM, Pout = Prated	-	5	-	%	
SEM	Pout ≤ Prated, +/- 100kHz	-	-32	-	dBm/30 kHz	
	Pout ≤ Prated, +/- 150kHz	-	-45	-		
	Pout ≤ Prated, +/- 300kHz	-	-49	-		
	Pout ≤ Prated, +/- 500 to 1700kHz	-	-58	-		
Harmonic suppression, 2fo	Band 1	Pout ≤ Prated	-	-60	-	dBm
	Bands 2, 25		-	-55	-	
	Bands 3, 4, 66		-	-41	-	
	Band 70		-	-42	-	
Harmonic suppression, 3fo	Band 1	Pout ≤ Prated	-	-51	-	
	Band 2, 25		-	-50	-	
	Band 3, 4, 66, 70		-	-56	-	

Electrical Specifications: NB-IoT: Band 1, 2, 3, 4, 25, 66, 70 - continued

(Temp = +25°C, Vbatt = 3.0V, VCC = 2.5V, VIO= +1.8V, 50 Ω system, Modulation used: QPSK 1tone@position0, 15 KHz subcarrier spacing, 1 tone with MPR=0, unless otherwise specified.)

Parameter	Conditions	Min.	Typ.	Max.	Units	
Rx Band Noise	Band 1 Rx	RX frequency 2110 – 2170 MHz	-	-142	-	dBm/Hz
	Band 2/25 Rx	RX frequency 1930 – 1995 MHz	-	-126	-	
	Band 3 Rx	RX frequency 1805 – 1880 MHz	-	-127	-	
	Band 4 Rx	RX frequency 2110 – 2155 MHz	-	-151	-	
	Band 66 Rx	RX frequency 2110 – 2200 MHz	-	-141	-	
	Band 70 Rx	RX frequency 1995 – 2020 MHz	-	-142	-	
WiFi Band Noise	Pout = Prated, 2400 – 2495MHz,	-	-146	-		
	Pout = Prated, 5150 – 5850MHz,	-	-160	-		
GPS band noise power	Pout = Prated, 1574 – 1577MHz,	-	-137	-		
Input VSWR	No external matching	-	2.5:1	-	-	
Gain Switching Time	Time required for output power to settle to within ±1dB of the final output power for any given mode transistion.	-	-	10	uSec	
Stability, Spurious Output Levels	Load VSWR = 10:1, all phase angles, Pin adjusted for Pout = 24dBm into 50Ω load	-	-	-36	dBm	

Electrical Specifications: Cat-M1 : Band 1, 2, 3, 4, 25, 39, 66, 70, 107

(Temp = +25°C, Vbatt = 3.0V, Vcc = 2.5V, VIO = +1.8V, 50 Ω system, Modulation used: LTE QPSK, 1.4MHz channel, 1 Resource Block with MPR=0, Band39 is TDD, other bands are FDD, unless otherwise specified.)

Parameter	Conditions	Min.	Typ.	Max.	Units
Frequency Range	Band 1	1920	1950	1980	MHz
	Band 2, 25	1850	1882.5	1915	
	Band 3, 66	1710	1747.5	1785	
	Band 4	1710	1732.5	1755	
	Band 39	1880	1900	1920	
	Band 70	1695	1702.5	1710	
	Band 107	1800	-	1810	
Maximum Linear Output Power	HPM	24	-	-	dBm
Gain	Band 1	-	27	-	dB
	Bands 2, 25, 39	-	27	-	
	Bands 3, 4, 66, 70	-	27.5	-	
	Band 107	-	27	-	
ACLR1 - EUTRA	Band 1	-	-39	-33	dBc
	Bands 2, 25, 39	-	-40		
	Bands 3, 4, 66, 70	-	-42		
	Band 107	-	-40		
ACLR1 - UTRA	Band 39	-	-42	-36	dBc
	Band 1	-	-45		
	Bands 2, 3, 4, 25, 66, 70	-	-46		
	Band 107	-	-42		
ACLR2 - UTRA		-	-63	-39	
PA Total Current	Band 1	-	386	-	mA
	Bands 2, 25, 39	-	375	-	
	Bands 3, 4, 66, 70	-	341	-	
	Band 107	-	370	-	
PAE	Band 1	-	26	-	%
	Bands 2, 25, 39	-	26.5	-	
	Bands 3, 4, 66, 70	-	29	-	
	Band 107	-	26	-	
EVM	HPM, Pout ≤ Prated	-	5	-	%
Harmonic suppression, 2fo	Band 1	-	-60	-	dBm
	Bands 2, 25, 39	-	-55	-	
	Bands 3, 4, 66, 70	-	-47	-	
	Band 107	-	-55	-	
Harmonic suppression, 3fo	Band 1	-	-47.5	-	dBm
	Bands 2, 25, 39	-	-50	-	
	Bands 3, 4, 66, 70	-	-54	-	

Electrical Specifications: Cat-M1 : Band 1, 2, 3, 4, 25, 39, 66, 70 - continued

(Temp = +25°C, Vbatt = 3.0V, Vcc = 2.5V, VIO= +1.8V, 50 Ω system, Modulation used: LTE QPSK, 1.4MHz channel, 1 Resource Block with MPR=0, Band39 is TDD, other bands are FDD, unless otherwise specified.)

Parameter		Conditions	Min.	Typ.	Max.	Units
Harmonic suppression, 3fo	Band 107	$P_{out} \leq P_{rated}$	-	-50	-	dBm
ISM noise power		2400 – 2447 MHz	-	-149	-	dBm/Hz
Rx Band Noise	Band 1 Rx	RX frequency 2110 – 2170 MHz	-	-140	-	
	Band 2/25 Rx	RX frequency 1930 – 1995 MHz	-	-126	-	
	Band 3 Rx	RX frequency 1805 – 1880 MHz	-	-127	-	
	Band 4 Rx	RX frequency 2110 – 2155 MHz	-	-142	-	
	Band 66 Rx	RX frequency 2110 – 2200 MHz	-	-142	-	
	Band 70 Rx	RX frequency 1995 – 2020 MHz	-	-141	-	
GPS band noise power		$P_{out} = P_{rated}$, 1574 – 1577MHz	-	-136	-	
Stability, Spurious Output Levels		Load VSWR = 6:1, all phase angles, Pin adjusted for $P_{out} = 24\text{dBm}$ into 50Ω load	-	-	-36	dBm

Electrical Specifications: NB-IoT : Band 5, 8, 12, 13, 14, 17, 18, 19, 20, 26, 28, 71, 85

(Temp = +25°C, Vbatt = 3.0V, VCC = 2.5V, VIO= +1.8V, 50 Ω system, Modulation used: 1tone@position0, NB-IoT, QPSK, 15 KHz subcarrier spacing, 1tone with MPR=0, unless otherwise specified)

Parameter		Conditions	Min.	Typ.	Max.	Units
Frequency Range		Band 12	699	707.5	716	MHz
		Band 28, 17	703	725.5	748	
		Band 13	777	782	787	
		Band 14	788	793	798	
		Band 26, 18, 19	814	831.5	849	
		Band 20	832	847	862	
		Band 8	880	897.5	915	
		Band 5	824	836.5	849	
		Band 71	663	680.5	698	
		Band 85	698	707	716	
Maximum Linear Output Power		HPM	24	-	-	dBm
Gain	Bands 5, 8, 18, 19, 20, 26	HPM, Pout = Prated	-	27.5	-	dB
	Bands 12, 13, 14, 17, 28, 71, 85		-	26.5	-	
GSM ACLR	Bands 5, 8, 20, 26, 18, 19	HPM, Prated – 2dB (MPR), Vcc = 2.5V, Modulation = QPSK 12tone@positon0..11, 15 KHz SC	-	-40	-29	dBc
	Bands 12, 13, 14, 17, 28, 71, 85		-	-44		
UTRA ACLR			-	-60	-46	
PA Total Current	Band 8	HPM, Pout = Prated	-	445	-	mA
	Bands 5, 18,19, 20, 26		-	408	-	
	Bands 12, 13, 14, 17, 28, 71, 85		-	389	-	
PAE	Band 8	HPM, Pout ≤ Prated	-	23	-	%
	Bands 5, 18,19, 20, 26		-	24.5	-	
	Band 12, 13, 14, 17, 28, 71, 85		-	26	-	
EVM		HPM, Pout ≤ Prated	-	5	-	%
SEM	Pout ≤ Prated, +/- 100kHz		-	-35	-	dBm/30 kHz
	Pout ≤ Prated, +/- 150kHz		-	-46	-	
	Pout ≤ Prated, +/- 300kHz		-	-49	-	
	Pout ≤ Prated, +/- 500 to 1700kHz		-	-54	-	

Electrical Specifications: NB-IoT : Band 5, 8, 12, 13, 14, 17, 18, 19, 20, 26, 28, 71, 85 - continued

(Temp = +25°C, Vbatt = 3.0V, VCC = 2.5V, VIO= +1.8V, 50 Ω system, Modulation used: 1tone@position0, NB-IoT, QPSK, 15 KHz subcarrier spacing, 1tone with MPR=0, unless otherwise specified)

Parameter		Conditions	Min.	Typ.	Max.	Units
Harmonic suppression, 2fo	Bands 12, 17, 71, 85	Pout ≤ Prated	-	-52	-	dBm
	Band 8		-	-49	-	
	Bands 5, 14, 18, 19, 20, 26		-	-52	-	
	Band 28		-	-53	-	
	Band 13		-	-58	-	
Harmonic suppression, 3fo	Bands 12, 17, 71, 85	Pout ≤ Prated	-	-46	-	dBm
	Band 8		-	-42	-	
	Bands 5, 14, 18, 19, 20, 26		-	-43	-	
	Band 28		-	-44	-	
	Band 13		-	-41	-	
Rx Band Noise	Band 71 Rx	617 -652 MHz	-	-123	-	dBm/Hz
	Band 85 Rx	728 -- 746 MHz	-	-125	-	
	Band 12 Rx	729 – 746 MHz	-	-125	-	
	Band 13 Rx	746 – 756 MHz	-	-131	-	
	Band 14 Rx	758 – 768 MHz	-	-131	-	
	Band 28 Rx	758 – 803 Mhz	-	-125	-	
	Band 26 Rx	859 – 894 MHz	-	-125	-	
	Band 20 Rx	791 – 821 MHz	-	-128	-	
	Band 8 Rx	925 – 960 MHz	-	-128	-	
WiFi Band Noise	Pout = Prated, 2400 – 2495MHz		-	-156	-	dBm/Hz
	Pout = Prated, 5150 – 5850MHz		-	-150	-	
GPS band noise power	Pout = Prated, 1574 – 1577MHz		-	-166	-	
Input VSWR	No external matching		-	2.5:1	-	-
Gain Switching Time	Time required for output power to settle to within ±1dB of the final output power for any given mode transission.		-	-	10	uSec
Stability, Spurious Output Levels	Load VSWR = 10:1, all phase angles, Pin adjusted for Pout = 24dBm into 50Ω load		-	-	-36	dBm

Electrical Specifications: Cat-M1 : Band 5, 8, 12, 13, 14, 17, 18, 19, 20, 26, 27, 28, 71, 85

(Temp = +25°C, Vbatt = 3.0V, Vcc = 2.5V, VIO= +1.8V, 50 Ω system, Modulation used: FDD-LTE QPSK, 1.4MHz channel, 1 Resource Block with MPR=0, unless otherwise specified.)

Parameter		Conditions	Min.	Typ.	Max.	Units
Frequency Range		Band 12	699	707.5	716	MHz
		Band 28, 17	703	725.5	748	
		Band 13	777	782	787	
		Band 14	788	793	798	
		Band 26, 18, 19	814	835.5	849	
		Band 27	807	815.5	824	
		Band 20	832	847	862	
		Band 8	880	897.5	915	
		Band 5	824	836.5	849	
		Band 71	663	680.5	698	
		Band 85	668	707	716	
Maximum Linear Output Power		HPM	24	-	-	dBm
Gain	Bands 5, 8, 18, 19, 20, 26, 27, 28	HPM, Pout = Prated	-	27	-	dB
	Bands 13, 14		-	27	-	
	Bands 12, 17, 71, 85		-	26.5	-	
ACLR1 – EUTRA	Bands 5, 8, 18, 19, 20, 26, 27	HPM, Prated – 2dB (MPR), Vcc = 2.5V, Modulation = 1.4MHz 6RB QPSK	-	-38	-33	dBc
	Bands 13, 14		-	-37		
	Bands 12, 17, 28, 71, 85		-	-43		
ACLR1 - UTRA	Bands 5, 8, 13, 14, 18, 19, 20, 26, 27		-	-41	-36	
	Bands 12, 17, 28, 71, 85		-	-43		
ACLR2 - UTRA				-	-63	
PA Total Current	Band 8	HPM, Pout = Prated	-	428	-	mA
	Bands 5, 13, 14, 18, 19, 20, 26, 27		-	396	-	
	Bands 12, 17, 28, 71, 85		-	380	-	
PAE	Band 8	HPM, Pout ≤ Prated	-	23	-	%
	Bands 5, 13, 14, 18, 19, 20, 26, 27		-	25	-	
	Band 12, 17, 28, 71, 85		-	26	-	
EVM		HPM, Pout ≤ Prated	-	5	-	%
Harmonic suppression, 2fo	Band 8	Pout ≤ Prated	-	-52	-	dBm
	Band 13		-	-56	-	
	Band 28		-	-53	-	
	Bands 12, 17, 71, 85		-	-50	-	
	Bands 5, 14, 18, 19, 20, 26, 27		-	-53	-	

Electrical Specifications: Cat-M1 : Band 5, 8, 12, 13, 14, 17, 18, 19, 20, 26, 27, 28, 71, 85 - continued

(Temp = +25°C, Vbatt = 3.0V, Vcc = 2.5V, VIO = +1.8V, 50 Ω system, Modulation used: FDD-LTE QPSK, 1.4MHz channel, 1 Resource Block with MPR=0, unless otherwise specified.)

Parameter		Conditions	Min.	Typ.	Max.	Units
Harmonic suppression, 3fo	Band 8	Pout ≤ Prated	-	-44	-	dBm
	Band 13		-	-41	-	
	Bands 5, 14, 18, 19, 20, 26, 27, 28		-	-43	-	
	Bands 12, 17, 71, 85		-	-44	-	
ISM noise power		2400 – 2447 MHz	-	-163	-	dBm/Hz
Rx Band Noise	Band 71 Rx	617 -- 652 MHz	-	-124	-	
	Band 85 Rx	728 -- 746 MHz	-	-126	-	
	Band 12 Rx	729 – 746 MHz	-	-126	-	
	Band 13 Rx	746 – 756 MHz	-	-132	-	
	Band 14 Rx	758 – 768 MHz	-	-132	-	
	Band 28 Rx	758 – 803 MHz	-	-127	-	
	Band 27 Rx	852 – 869 MHz	-	-126	-	
	Band 26 Rx	859 – 894 MHz	-	-127	-	
	Band 20 Rx	791 – 821 MHz	-	-126	-	
Band 8 Rx	925 – 960 MHz	-	-125	-		
GPS band noise power		Pout = Prated, 1574 – 1577MHz	-	-166	-	
Stability, Spurious Output Levels		Load VSWR = 6:1, all phase angles, Pin adjusted for Pout = 24dBm into 50Ω load	-	-	-36	dBm

Electrical Specifications: NTN : Band 23, Band 24, Band 255, Band 256

(Temp = +25°C, Vbatt = 3V, VCC = 3.2V, VIO = +1.8V, 50 Ω system, Modulation used: 1tone@position0, NB-IoT, QPSK, 15 KHz subcarrier spacing, 1tone with MPR=0, unless otherwise specified)

PARAMETER		CONDITIONS	MIN.	TYP.	MAX.	UNITS	
Frequency Range	Band 23		2000	-	2020	MHz	
	Band 24		1625.5	-	1660.5		
	Band 255		1626.5	-	1660.5		
	Band 256		1980		2010		
Maximum Linear Output Power		HPM, NTC		24	-	dBm	
Gain	Band 23	Pout = 24 dBm		25		dB	
	Band 24			28	-		
	Band 255			28	-		
	Band 256			25			
GSM ACLR	Band 23	HPM, Prated – 2dB (MPR), Vcc = 3.2V, Modulation = QPSK 12tone@positon0..11, 15 KHz SC	-	-36	-	dBc	
	Band 24		-	-36	-		
	Band 255		-	-36	-		
	Band 256			-36			
UTRA	Band 23			-	-65		-
	Band 24			-	-63		-
	Band 255			-	-63		-
	Band 256				-65		
PA Total Current	Band 23	HPM, Pout = 24 dBm	-	350	-	mA	
	Band 24		-	357	-		
	Band 255		-	357	-		
	Band 256			350			
PAE	Band 23	HPM, Pout = 24 dBm	-	22	-	%	
	Band 24		-	22	-		
	Band 255		-	22	-		
	Band 256			22			
EVM	Band 23	HPM, Pout = 24 dBm		0.5		%	
	Band 24			0.4			
	Band 255			0.4			
	Band 256			0.5			
Harmonic, 2fo	Band 23	Pout ≤ Prated	-	-60	-	dBm	
	Band 24		-	-46	-		
	Band 255		-	-46	-		
	Band 256			-60			
Harmonic, 3fo	Band 23	Pout ≤ Prated	-	-48	-	dBm	
	Band 24		-	-58	-		
	Band 255		-	-58	-		
	Band 256			-48			
Input VSWR		No external matching	-	2.5:1	-		
Gain Switching Time		Time required for output power to settle to within ±1dB of the final output power for any given mode transition.	-	-	10	uSec	

Electrical Specifications: NTN : Band 23, Band 24, Band 255, Band 256

(Temp = +25°C, Vbatt = 3V, VCC = 3.2V, VIO= +1.8V, 50 Ω system, Modulation used: FDD-LTE QPSK, 1.4MHz channel, 1 Resource Block with MPR=0, unless otherwise specified.)

PARAMETER		CONDITIONS	MIN.	TYP.	MAX.	UNITS
Frequency Range		Band 23	2000	-	2020	MHz
		Band 24	1625.5	-	1660.5	
		Band255	1626.5	-	1660.5	
		Band 256	1980		2010	
Maximum Linear Output Power		HPM, NTC		24	-	dBm
Gain	Band 23	Pout = 24 dBm		25		dB
	Band 24			28	-	
	Band 255			28	-	
	Band 256			25		
ACLR-EUTRA	Band 23	HPM, Prated – 2dB (MPR), Vcc = 3.2V, Modulation = 1.4MHz 6RB QPSK	-	-38	-	dBc
	Band 24		-	-38	-	
	Band 255		-	-38	-	
	Band 256			-38		
ACLR1 - UTRA	Band 23		-	-42	-	
	Band 24		-	-38	-	
	Band 255		-	-38	-	
	Band 256			-42		
PA Total Current	Band 23	HPM, Pout = 24 dBm	-	290	-	mA
	Band 24		-	294	-	
	Band 255		-	294	-	
	Band 256			290		
PAE	Band 23	HPM, Pout = 24 dBm	-	26	-	%
	Band 24		-	26	-	
	Band 255		-	26	-	
	Band 256			26		
EVM	Band 23	HPM, Pout = 24 dBm		4		%
	Band 24			2		
	Band 255			2		
	Band 256			4		
Harmonic, 2fo	Band 23	Pout ≤ Prated	-	-56	-	dBm
	Band 24		-	-42	-	
	Band 255		-	-42	-	
	Band 256			-56		
Harmonic, 3fo	Band 23	Pout ≤ Prated	-	-43	-	dBm
	Band 24		-	-56	-	
	Band 255		-	-56	-	
	Band 256			-43		
Input VSWR		No external matching	-	2.5:1	-	
Gain Switching Time		Time required for output power to settle to within ±1dB of the final output power for any given mode transition.	-	-	10	uSec

Electrical Specifications: Switch And Port Isolation

(Temp = +25°C, Nominal test conditions unless otherwise specified. All unused ports terminated in 50Ω. Logic state given in register table.)

Parameter	Conditions	Min.	Typ.	Max.	Units
Insertion Loss, IL	ANT to Rx_LB, 600 – 960MHz	-	2	-	dB
	ANT to Rx_HB, 1525 – 2200MHz	-	1.7	-	
	ANT to AUX1, 600 – 2200MHz	-	1.5	-	
	ANT to AUX2, 600 – 2200MHz	-	1	-	
Isolation, ISO	ANT to Rx_LB, 600 – 960MHz	-	43	-	dB
	ANT to Rx_LB, 1525 – 2200MHz	-	57	-	
	ANT to Rx_HB, 600 – 960MHz	-	42	-	
	ANT to Rx_HB, 1525 – 2200MHz	-	27	-	
	ANT to AUX1, 600 – 2200MHz	-	30	-	
	ANT to AUX2, 600 – 2200MHz	-	30	-	
2 nd Harmonic	ANT to Rx_LB, 1458 – 1920MHz	-	-30	-	dBc
	ANT to Rx_HB, 3050 – 4400MHz	-	-35	-	
3 rd Harmonic	ANT to Rx_LB, 2187 – 2880MHz	-	-40	-	
	ANT to Rx_HB, 4575 – 6510MHz	-	-43	-	
Rx port return loss	Rx_LB, 600 – 960MHz	-	16	-	dB
	Rx_HB, 1525 – 2200MHz	-	14	-	
	AUX1, 600 – 2200MHz	-	10	-	
	AUX2, 600 – 2200MHz	-	12	-	
ANT port return loss	ANT to Rx_LB, 600 – 960MHz	-	15	-	dB
	ANT to Rx_HB, 1525 – 2200MHz	-	14	-	
	ANT to AUX1, 600 – 2200MHz	-	9	-	
	ANT to AUX2, 600 – 2200MHz	-	10	-	

Table 1: RFFE MIPI Register Map (1 of 4)

Register Details

This section displays each register in table form. Table headers described here:

TRIG. – Indicates whether the Write Command can be triggered. The value in the Trig. Column indicates which trigger causes the Bit Field to be loaded from the shadow register. “T012” means that any or all triggers will cause a load from shadow register.

Register 0 (0x00) – PA_CTRL0

BIT(S)	FIELD NAME	DEFAULT	DESCRIPTION	R/W	B/G	TRIG.
7:6	Reserved[1:0]	0b00	This is a read-only bit that is reserved and yields a value of 0 at readback	R	No	No
5:3	PA_BAND[2:0]	0b000	PA Band 000: off 001: AUX2 010: AUX1 011: RX_HB 100: LB_TX 101: Reserved 110: MB_TX 111: RX_LB	R/W		T012
2	TX_EN[2]	0b0	Transmit Enable 0 = Transmit mode disabled 1 = Transmit mode enabled Set this bit to 1 to turn on the module's PA for LB or MB transmit or to use one of the four TRX ports in transmit mode.	R/W		T012
1	PA_MODE[1]	0b0	PA Power Control Mode 0 = HPM 1 = LPM	R/W		No
0	Reserved[0]	0b0	This is a read-only bit that is reserved and yields a value of 0 at readback.	R/W		No

Register 1 (0x01) – PA_CTRL1

BIT(S)	FIELD NAME	DEFAULT	DESCRIPTION	R/W	B/G	TRIG.
7:4	PA_BIAS2[3:0]	0b0000	PA Bias – power stage	R/W	No	T012
3:0	PA_BIAS1[3:0]	0b0000	PA Bias – driver stage	R/W	No	T012

Register 2 (0x02) – PA_CTRL2

BIT(S)	FIELD NAME	DEFAULT	DESCRIPTION	R/W	B/G	TRIG.
7:4	Reserved[3:0]	0b0000	These are a read-only bits that are reserved and yield a value of 0 at readback.	R/W	No	No
3:0	PA_TUNE[3:0]	0b0000	PA Tuning Cap	R/W	No	T012

Table 1: RFFE MIPI Register Map (2 of 4)

Register 26 (0x1A) – RFFE_STATUS

BIT(S)	FIELD NAME	DEFAULT	DESCRIPTION	R/W	B/G	TRIG.
7	SW_RESET[7]	0b0	0: Normal operation 1: Software reset (reset of all configurable registers to default values, except for USID&GSID)	R/W	No	No
6	CMD_FRAME_P_ERR[6]	0b0	Command sequence received with parity error – discard command.			
5	CMD_LEN_ERR[5]	0b0	Command length error			
4	ADDR_FRAME_P_ERR[4]	0b0	Address frame parity error = 1			
3	DATA_FRAME_P_ERR[3]	0b0	Data Frame received with a parity error			
2	READ_UNUSED_REG[2]	0b0	Read Command to an invalid address			
1	WRITE_UNUSED_REG[1]	0b0	Write command to an invalid address			
0	BID_GID_ERR[0]	0b0	Read command with a Broadcast_ID or GROUP_ID			

Register 27 (0x1B) – GROUP_ID

BIT(S)	FIELD NAME	DEFAULT	DESCRIPTION	R/W	B/G	TRIG.
7:4	GSID0[3:0]	0b0000	Group Slave ID 0	R/W	No	No
3:0	GSID1[3:0]	0b0000	Group Slave ID 1			

Register 28 (0x1C) – PM_TRIG

BIT(S)	FIELD NAME	DEFAULT	DESCRIPTION	R/W	B/G	TRIG.
7	PWR_MODE_MSB[7]	0b1	0: Normal operation (ACTIVE) 1: Secondary mode (LOW POWER)	R/W	Yes	No
6	PWR_MODE_LSB[6]	0b0	RFFE State machine vector. 0: active mode 1: in reset state Writing a 1 to this bit forces a reset. All registers including USID and GSID are reset to default values. This bit always reads as 0.	R/W	Yes	No
5:3	TriggerMask[2:0]	0b000	Setting these bits to '1' will cause the corresponding triggers to be masked (disabled), and RFFE writes to corresponding registers will change configuration immediately (no trigger command necessary). TriggerMask[2] = TriggerMask_2, TriggerMask[1] = TriggerMask_1,&TriggerMask[0] = TriggerMask_0 Note: Qorvo does not allow for changing the trigger mask and sending triggers within the same RFFE write.	R/W	No	No
2:0	Trigger[2:0]	0b000	Setting these bits to '1' will cause the registers associated with that trigger to be loaded with the contents of its corresponding shadow register. Trigger[2] = Trigger_2, Trigger[1] = Trigger_1, and Trigger[0] = Trigger_0 Note: Qorvo does not allow for changing the trigger mask and sending triggers within the same RFFE write.	W	Yes	No

Table 1: RFFE MIPI Register Map (3 of 4)

Register 29 (0x1D) – PRODUCT_ID

BIT(S)	FIELD NAME	DEFAULT	DESCRIPTION	R/W	B/G	TRIG.
7:0	PRODUCT_ID[7:0]	0x07	This is a read-only register. However, during the programming of the USID a write command sequence is performed on this register, even though the write does not change its value.	R	No	No

Register 30 (0x1E) – MANUFACTURER_ID

BIT(S)	FIELD NAME	DEFAULT	DESCRIPTION	R/W	B/G	TRIG.
7:0	MANUFACTURER_ID_LSB[7:0]	0xC6	This is a read-only register. However, during the programming of the USID, a write command sequence is performed on this register, even though the write does not change its value. Note: This is the lower 8 least significant bits of the RFFE's MANUFACTURER_ID (i.e. MANUFACTURER_ID[7:0] = MANUFACTURER_ID_LSB[7:0] Qorvo Manufacturer ID = 0x3C6 = 0011_1100_0110	R	No	No

Register 31 (0x1F) – MAN_US_ID

BIT(S)	FIELD NAME	DEFAULT	DESCRIPTION	R/W	B/G	TRIG.
7:4	MANUFACTURER_ID_MSB[3:0]	0b0011	These bits are read-only. However, during the programming of the USID, a write command sequence is performed on this register even though the write does not change its value. Note: This is the 4 most significant bits of the RFFE's MANUFACTURER_ID (i.e. MANUFACTURER_ID[11:8] = MANUFACTURER_ID_MSB[3:0]	R	No	No
3:0	USID[3:0]	0b1111	Programmable USID. Performing a write to this register using the described programming sequences will program the USID in devices supporting this feature. These bits store the USID of the device.	R/W	No	No

Register 32 (0x20) – EXT_PRODUCT_ID

BIT(S)	FIELD NAME	DEFAULT	DESCRIPTION	R/W	B/G	TRIG.
7:0	EXT_PRODUCT_ID[7:0]	0x00	This is a read-only register. However, during the programming of the USID a write command sequence is performed on this register, even though the write does not change its value.	R	No	No

Register 33 (0x21) – REVISION_ID

BIT(S)	FIELD NAME	DEFAULT	DESCRIPTION	R/W	B/G	TRIG.
7:0	REVISION_ID	0x01	This is an RFFE2 register to contain information about the revision of this module.	R	No	No

Table 1: RFFE MIPI Register Map (4 of 4)

Register 34 (0x22) – GROUP_ID2

BIT(S)	FIELD NAME	DEFAULT	DESCRIPTION	R/W	B/G	TRIG.
7:4	GSID0_2[3:0]	0x00	Group slave ID 0 There is only 1 register for GSID0&GSID1, but this register can be accessed from either Reg27 or Reg34. This means that write to Reg34 will reflect in Reg27 also, and vice versa	R/W	No	No
3:0	GSID1_2[3:0]	0x00	Group slave ID 1 There is only 1 register for GSID0&GSID1, but this register can be accessed from either Reg27 or Reg34. This means that write to Reg34 will reflect in Reg27 also, and vice versa			

Register 35 (0x23) – RFFE_STATUS2

BIT(S)	FIELD NAME	DEFAULT	DESCRIPTION	R/W	B/G	TRIG.
7	SW_RESET_2[7]	0b0	0: Normal operation 1: Software reset (reset of all configurable registers to default values, except for USID) There is only 1 register for RFFE_STATUS, but this register can be accessed from either Reg26 or Reg35. This means that write to Reg35 will reflect in Reg27 also, and vice versa	R/W	No	No
6	Reserved[6]	0b0	Reserved			
5	Reserved[5]	0b0	Reserved			
4	Reserved[4]	0b0	Reserved			
3	Reserved[3]	0b0	Reserved			
2	Reserved[2]	0b0	Reserved			
1	Reserved[1]	0b0	Reserved			
0	Reserved[0]	0b0	Reserved			

Register 36 (0x24) – ERR_SUM (RFFE_STATUS3)

BIT(S)	FIELD NAME	DEFAULT	DESCRIPTION	R/W	B/G	TRIG.
7	Reserved[7]	0b0	Reserved	R/W	No	No
6	CMD_FRAME_P_ERR_2[6]	0b0	Command sequence received with parity error – discard command.			
5	CMD_LEN_ERR_2[5]	0b0	Command length error			
4	ADDR_FRAME_P_ERR_2[4]	0b0	Address frame parity error = 1			
3	DATA_FRAME_P_ERR_2[3]	0b0	Data frame with parity error			
2	READ_UNUSED_REG_2[2]	0b0	Read command to an invalid address			
1	WRITE_UNUSED_REG_2[1]	0b0	Write command to an invalid address			
0	BID_GID_ERR_2[0]	0b0	Read command with a Broadcast_ID or GROUP_ID			

Evaluation Board Schematic

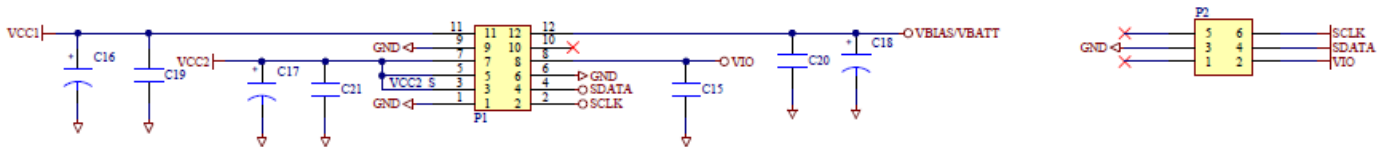
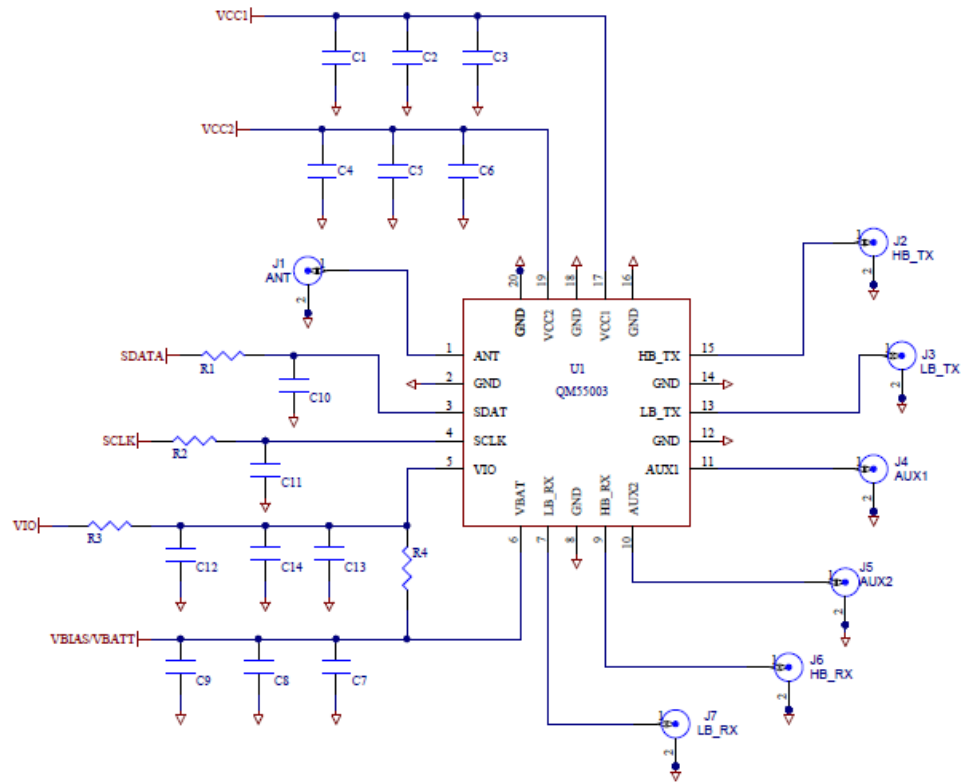

Evaluation Board Layout

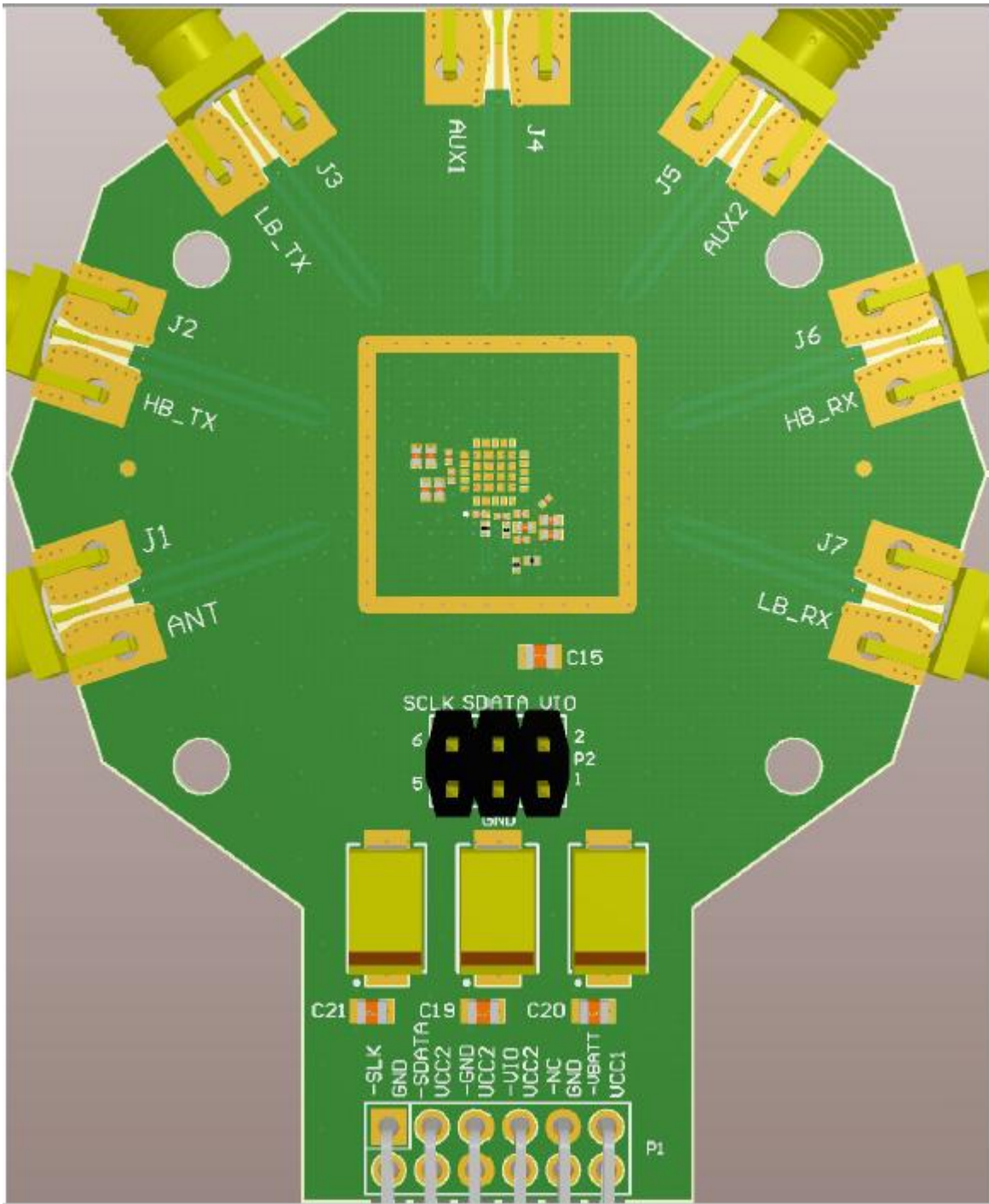

Evaluation Board Bill of Material

Designator	Description	Manuf.	Part number
C16, C17, C18	CAP, 100uF, 20%, 10V, TANT-D	AVX/KYOCERA ASIA LTD.	TAJD107M010RNJ
C19, C21, C15, C20	CAP, 10uF, 10%, 6.3V, X5R, 0805	TAIYO YUDEN (SINGAPORE) PTE LTD	CE JMK212BJ106KG-T
R3	RES, 0 OHM, 5%, 1/20W, 0201	Kamaya, Inc	RMC1/20JPPA15
R1, R2	RES, 49.9 OHM, 1%, 1/20W, 0201	Kamaya, Inc	RMC1/20-49R9FPA15
C10, C11	CAP, 10pF, 5%, 25V, C0G, 0201	AVX/KYOCERA ASIA LTD.	02013A100JAT2A
C2, C5, C8, C14	5600 PF,10%,X7R,LF,0402, 25V,LEAD FREE	MURATA ELECTRONICS SINGAPORE PTE LT	GRM155R71E562KA01D
C3, C6, C7, C12	CAP, 100pF, 5%, 25V, C0G, 0201	MURATA ELECTRONICS SINGAPORE PTE LT	GRM0335C1E101JA01D
P1	CONN, HDR, SHRD, RT-ANG, 2x6, 0.100",T/H	MOLEX	90130-3212
P2	CONN, HDR, ST, 2X3, 0.100"	SAMTEC INC.	TSW-103-07-G-D
J1, J2, J3, J4, J5, J6, J7	CONN, SMA, EL FLT VIPER, MAT-21-1038	Aliner Industries, Inc.	20-001CH-T
C1, C4, C9	-	-	-
C13	-	-	-
R4	-	-	-

Pin Configuration

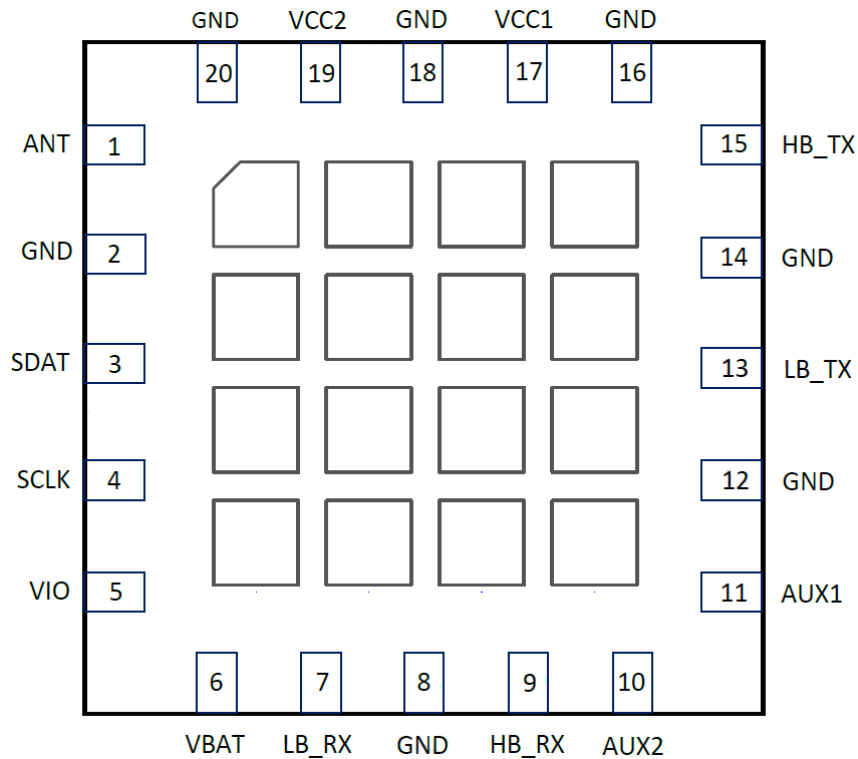

Top View (see through from top)

Pin Description

Pin Number	Label	Description
1	ANT	RF Output port.
2	GND	Connected to module gnd.
3	SDATA	Serial interface data I/O signal.
4	SCLK	Serial interface clock input signal.
5	VIO	Supply voltage for MIPI RFFE.
6	VBAT	Supply voltage for bias circuitry.
7	LB_RX	LB receive port.
8	GND	Connected to module gnd.
9	HB_RX	HB receive port.
10	AUX2	Auxillary transimit port 2.
11	AUX1	Auxillary transimit port 1.
12, 14, 16, 18, 20	GND	Connected to module gnd.
13	LB_TX	LB RF Input
15	HB_TX	HB RF Input
17	VCC1	Driver stage supply of PA.
19	VCC2	Output stage supply of PA.

Package Land Pattern

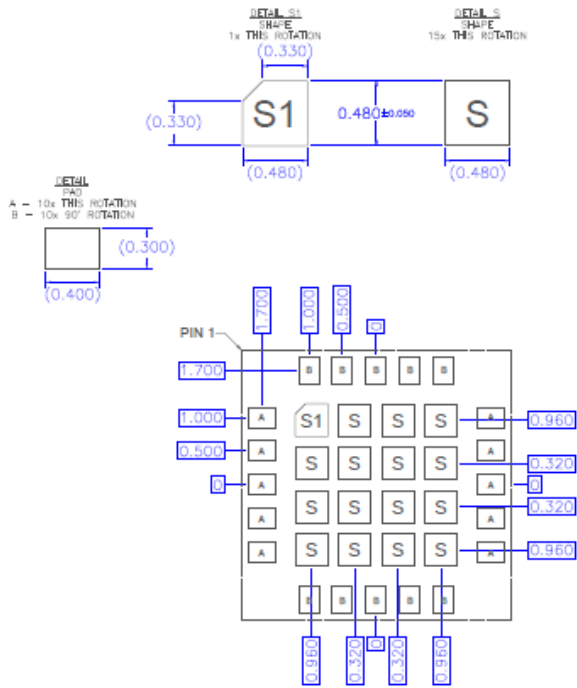

RECOMMENDED
LAND PATTERN

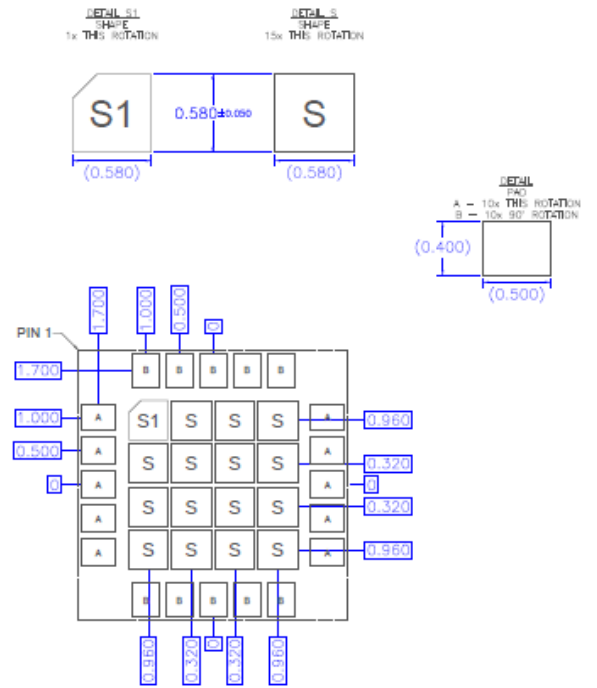

RECOMMENDED
LAND PATTERN MASK

Tape and Reel Information - Carrier and Cover Tape Dimensions

Tape and reel specifications for this part are also available on the Qorvo website.
Standard T/R size = 5000 pieces on a 13" reel.

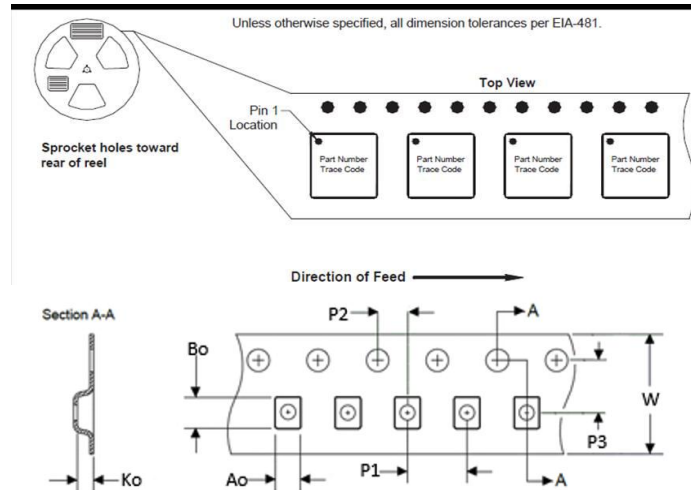

Feature	Measure	Symbol	Size (in)	Size (mm)
Cavity	Length	A0	0.169	4.3
	Width	B0	0.169	4.3
	Depth	K0	0.059	1.5
	Pitch	P1	0.315	8
Centerline Distance	Cavity to Perforation - Length Direction	P2	0.079	2.0
	Cavity to Perforation - Width Direction	P3	0.217	5.5
Cover Tape	Width	C	0.362	9.2
Carrier Tape	Width	W	0.472	12

Tape and Reel Information - Reel Dimensions

Packaging reels are used to prevent damage to devices during shipping, handling and storage, loaded carrier tape is typically wound onto a plastic take-up reel. The reel size is 13" diameter. The reels are made from high-impact injection-molded polystyrene (HIPS), which offers mechanical and ESD protection to packaged devices

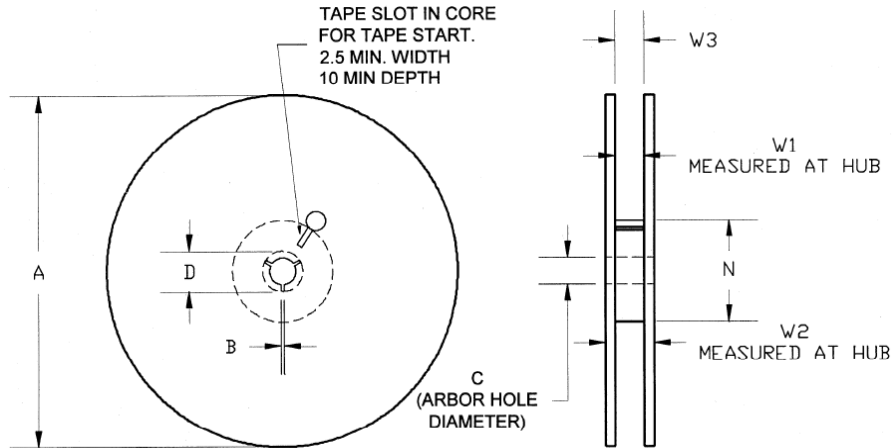

Feature	Measure	Symbol	Size (in)	Size (mm)
Flange	Diameter	A	12.992	330
	Thickness	W2	.724	18.4
	Space Between Flange	W1	.488	12.4
Hub	Outer Diameter	N	4.016	102.0
	Arbor Hole Diameter	C	0.512	13.0
	Key Slit Width	B	0.079	2.0
	Key Slit Diameter	D	.795	20.2

Tape and Reel Information - Tape Length and Label Placement

Tape and reel specifications for this part are on Qorvo website.

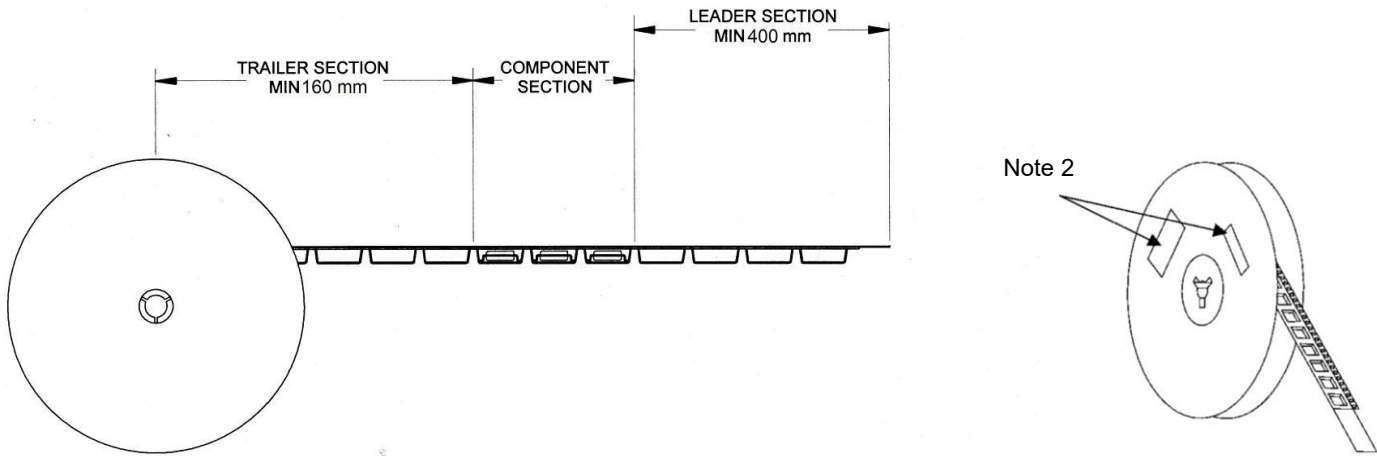

Notes:

1. Empty part cavities at the trailing and leading ends are sealed with cover tape. See EIA 481
2. Labels are placed on the flange opposite the sprockets in the carrier tap

Handling Precautions

Parameter	Rating	Standard
ESD – Human Body Model (HBM)	Class 1C	ESDA/JEDEC JS-001-2012
ESD – Charged Device Model (CDM)	Class C3	JEDEC JESD22-C101F
MSL – Moisture Sensitivity Level	MSL 3	IPC/JEDEC J-STD-020



Caution!

ESD sensitive device

Solderability

Compatible with both lead-free (260 °C max. reflow temperature) and tin/lead (245 °C max. reflow temperature) soldering processes.

Package lead plating: Electrolytic plated Au over Ni

RoHS Compliance

This part is compliant with the 2011/65/EU RoHS directive (Restrictions on the Use of Certain Hazardous Substances in Electrical and Electronic Equipment), as amended by Directive 2015/863/EU.

This product also has the following attributes:

- Halogen Free (Chlorine, Bromine)
- Antimony Free
- TBBP-A (C₁₅H₁₂Br₄O₂) Free
- SVHC Free

Contact Information

For the latest specifications, additional product information, worldwide sales and distribution locations:

Web: www.qorvo.com

Tel: 1-844-890-8163

Email: customer.support@qorvo.com

Important Notice

The information contained herein is believed to be reliable; however, Qorvo makes no warranties regarding the information contained herein and assumes no responsibility or liability whatsoever for the use of the information contained herein. All information contained herein is subject to change without notice. Customers should obtain and verify the latest relevant information before placing orders for Qorvo products. The information contained herein or any use of such information does not grant, explicitly or implicitly, to any party any patent rights, licenses, or any other intellectual property rights, whether with regard to such information itself or anything described by such information. **THIS INFORMATION DOES NOT CONSTITUTE A WARRANTY WITH RESPECT TO THE PRODUCTS DESCRIBED HEREIN, AND QORVO HEREBY DISCLAIMS ANY AND ALL WARRANTIES WITH RESPECT TO SUCH PRODUCTS WHETHER EXPRESS OR IMPLIED BY LAW, COURSE OF DEALING, COURSE OF PERFORMANCE, USAGE OF TRADE OR OTHERWISE, INCLUDING THE IMPLIED WARRANTIES OF MERCHANTABILITY AND FITNESS FOR A PARTICULAR PURPOSE.**

Without limiting the generality of the foregoing, Qorvo products are not warranted or authorized for use as critical components in medical, life-saving, or life-sustaining applications, or other applications where a failure would reasonably be expected to cause severe personal injury or death.

Copyright 2016 © Qorvo, Inc. | Qorvo is a registered trademark of Qorvo, Inc.