

QPL9065 - 223MHz-235MHz Reference Design

Product Overview

The QPL9065 is a high-linearity, ultra-low noise 2-stage gain block amplifier module with a bypass mode functionality integrated to the second stage in the product. At 1.95GHz, the amplifier, under high gain mode, typically provides 37.5dB gain, +36dBm OIP3, and 0.55dB noise figure while drawing 160mA current from a +5V supply. The component also provides high performance in the low gain mode with 17.5dB gain, 0.55dB noise figure and +33dBm OIP3 while drawing 70mA current.

The QPL9065 uses a high-performance E-pHEMT process. This low noise amplifier contains an internal active bias to maintain high performance over temperature.

The QPL9065 covers the 0.45 – 3.8GHz frequency band and is targeted for wireless infrastructure. The QPL9065 is housed in a 3.5x3.5mm SMT package

Referenced Documents

The reference documents below take precedence over the contents of this application note, and should always be consulted for the latest information.

QPL9065 Data Sheet.

APPLICATION NOTE: QPL9065 - 223MHz-235MHz Reference Design

Application Electrical Performance

Qorvo Field and Factory Applications Engineers are available to provide technical assistance for determining appropriate matching networks for a particular application.

| Parameter | Conditions | Typical Value | | Units |
|--------------------|----------------|-----------------------------|------|-------|
| Frequency | | 233 | 235 | MHz |
| Gain | High Gain Mode | 51.7 | 51.8 | dB |
| Input Return Loss | | 25.2 | 25.9 | dB |
| Output Return Loss | | 14.8 | 13.9 | dB |
| Noise Figure | | 0.60 | 0.64 | dB |
| Output P1dB | | 18.3 | 17.9 | dBm |
| Output IP3 | | Pout= +3dBm/tone, Δf= 1 MHz | 33.3 | 33.5 |
| Gain | Low Gain Mode | 23.4 | 23.4 | dB |
| Input Return Loss | | 14.6 | 16.4 | dB |
| Output Return Loss | | 7.9 | 7.2 | dB |
| Noise Figure | | 0.60 | 0.63 | dB |
| Output P1dB | | - | - | dBm |
| Output IP3 | | Pout= +3dBm/tone, Δf= 1 MHz | 28.3 | 29.9 |

Test conditions unless otherwise noted: VDD = +5.0 V, Temp = +25 °C, 50 Ω system. Noise figure data with input trace and matching component losses.

APPLICATION NOTE: QPL9065 - 223MHz-235MHz Reference Design

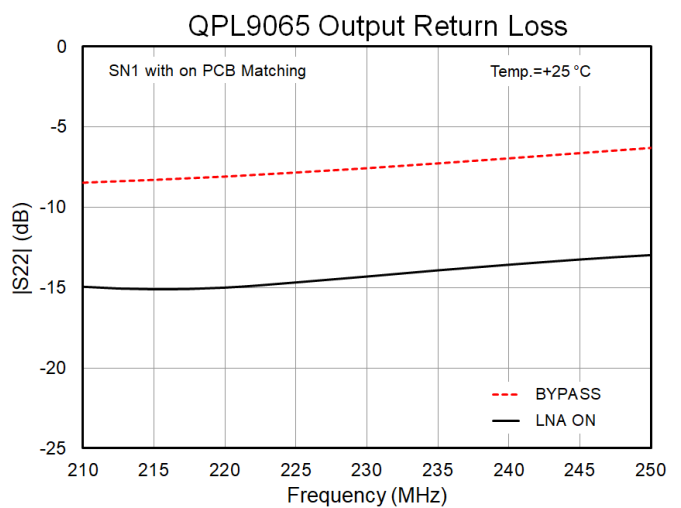
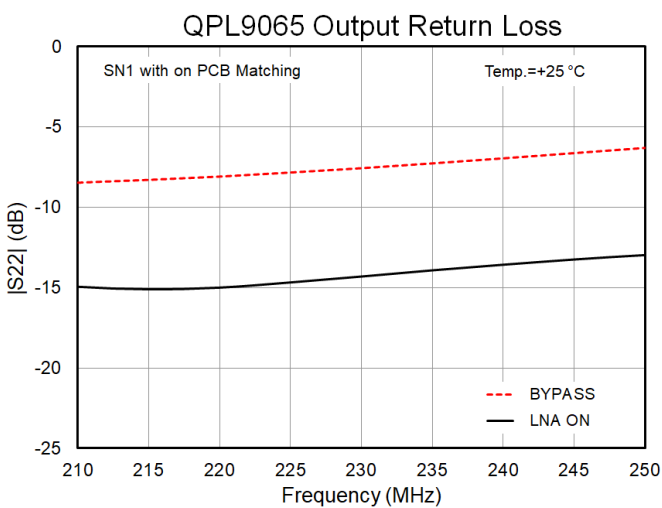
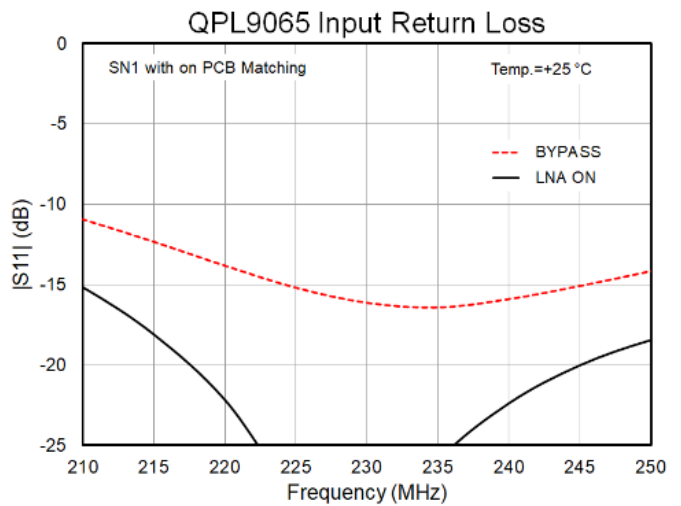
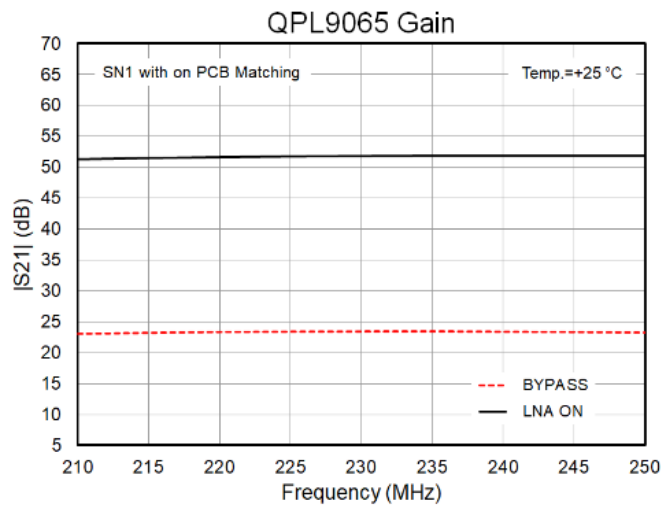

APPLICATION NOTE: QPL9065 - 223MHz-235MHz Reference Design

QPL9065 Noise Figure

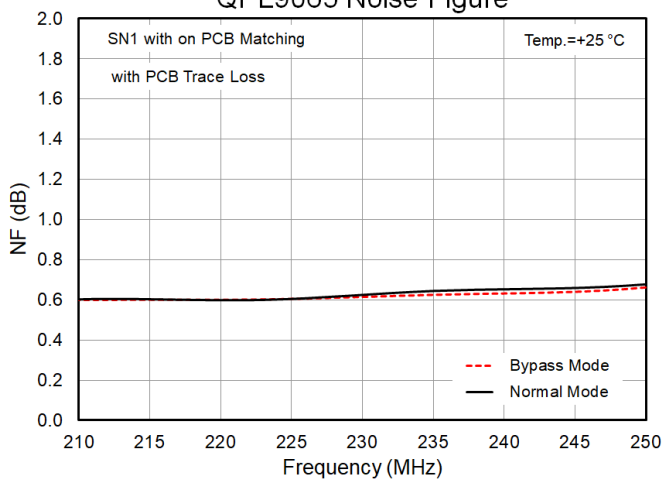

QPL9065 Gain vs. Pout

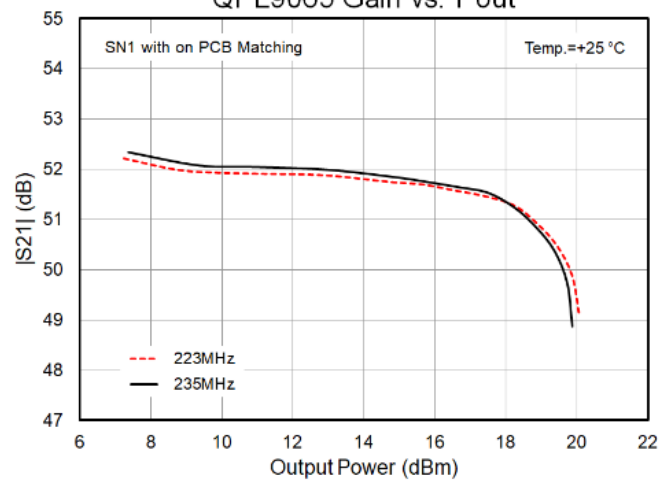

QPL9065 OIP3

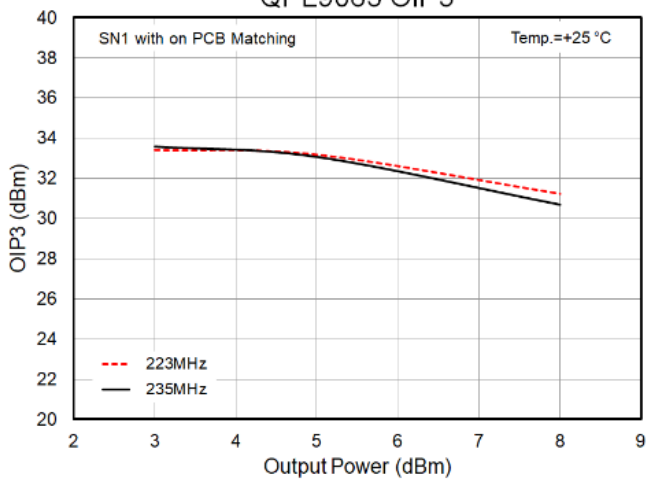

QPL9065 OIP3

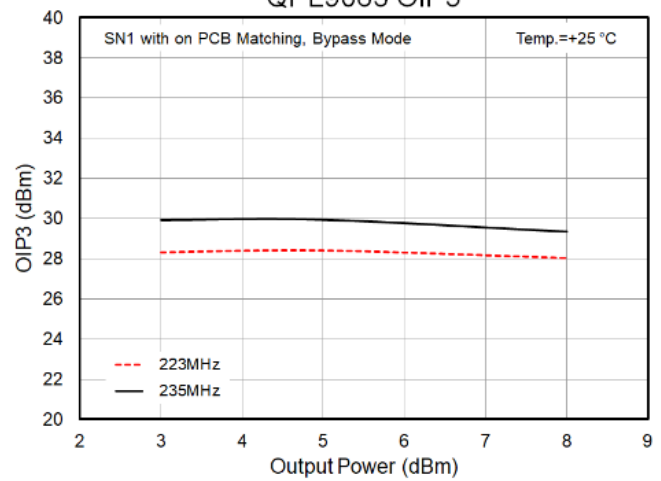

APPLICATION NOTE: QPL9065 - 223MHz-235MHz Reference Design

Evaluation Board Information

Evaluation Board and Schematic

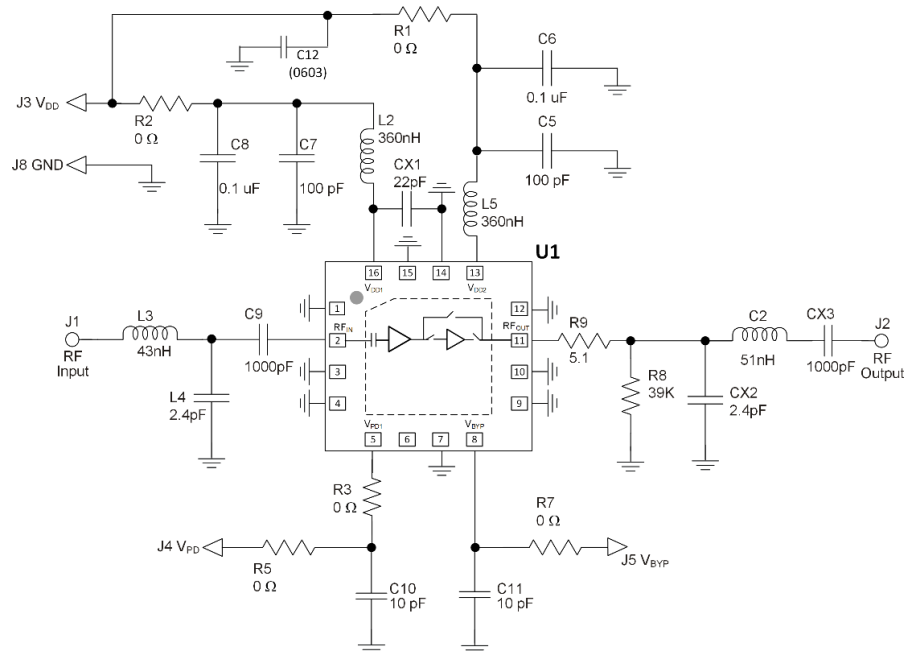
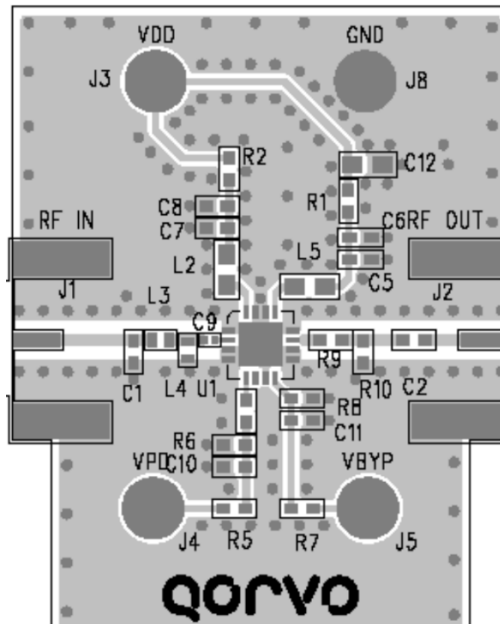

Notes:

1. See Evaluation Board PCB Information section for PCB material and stack-up.

APPLICATION NOTE: QPL9065 - 223MHz-235MHz Reference Design

Evaluation Board – Bill of Material

| Reference Des. | Value | Description | Manuf. | Part Number |
|----------------|--------|---------------------------------|-----------|-------------------|
| - | - | PCB | Qorvo | 1123139 |
| U1 | - | 2-Stage Bypass LNA | Qorvo | QPL9065 |
| C2 | 51nH | IND, 51nH, 2%, 0402 | Murata | LQW15AN51NG80 |
| C5, C7 | 100pF | CAP, 100pF, +/-5%, 50V, 0402 | Various | - |
| C6, C8 | 0.1μF | CAP, 0.1μF, 20%, 16V, Y5V, 0603 | Various | - |
| C9, CX3 | 1000pF | CAP, 1000pF, 5%, 50V, C0G, 0402 | Various | - |
| C10, C11 | 10pF | CAP, 10pF, 2%, 50V, 0402 | Murata | GRM0335C1H100GA01 |
| C12 | 4.7μF | CAP, 4.7μF, 20%, 10V, Y5V, 0603 | Various | - |
| CX1 | 22pF | CAP, 22pF, 2%, 50V, 0402 | Murata | GRM1555C1H220GA01 |
| CX2, L4 | 2.4pF | CAP, 2.4pF, 0.1%, 50V, 0402 | Murata | GRM1555C1H24BA01 |
| L2, L5 | 360nH | IND, 360nH, 5%, 0603 | Coilcraft | 0606HP-R36XJLU |
| L3 | 43nH | IND, 43nH, 2%, 0402 | Murata | LGW15AN43NG80 |
| R1, 2, 3, 5, 7 | 0Ω | RES, 0Ω, +/-5%, 1/16W, 0402 | Various | - |
| R9 | 5.1Ω | RES, 5.1Ω, +/-5%, 1/16W, 0402 | Various | - |
| R10 | 39K | RES, 39K, +/-5%, 1/16W, 0402 | Various | - |

APPLICATION NOTE: QPL9065 - 223MHz-235MHz Reference Design

Evaluation Board PCB Board Layers

PC Board Layout

PCB 1123139 Material (stack up)

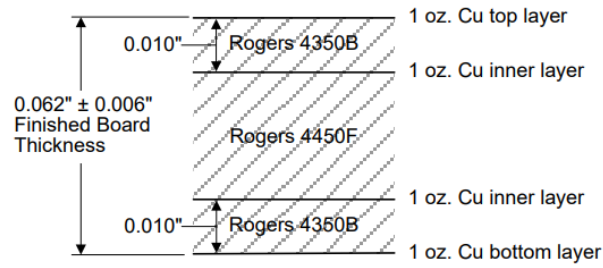

50-ohm line dimensions: width = 0.020", spacing = 0.032"

APPLICATION NOTE: QPL9065 - 223MHz-235MHz Reference Design

Additional Information

For information on ESD, Soldering Profiles, Packaging Standards, Handling and Assembly, please contact Qorvo for general guidelines.

Contact Information

For the latest specifications, additional product information, worldwide sales and distribution locations:

Web: www.qorvo.com

Tel: 1-844-890-8163

Email: customer.support@qorvo.com

Important Notice

The information contained in this Data Sheet and any associated documents ("Data Sheet Information") is believed to be reliable; however, Qorvo makes no warranties regarding the Data Sheet Information and assumes no responsibility or liability whatsoever for the use of said information. All Data Sheet Information is subject to change without notice. Customers should obtain and verify the latest relevant Data Sheet Information before placing orders for Qorvo® products. Data Sheet Information or the use thereof does not grant, explicitly, implicitly or otherwise any rights or licenses to any third party with respect to patents or any other intellectual property whether with regard to such Data Sheet Information itself or anything described by such information.

DATA SHEET INFORMATION DOES NOT CONSTITUTE A WARRANTY WITH RESPECT TO THE PRODUCTS DESCRIBED HEREIN, AND QORVO HEREBY DISCLAIMS ANY AND ALL WARRANTIES WITH RESPECT TO SUCH PRODUCTS WHETHER EXPRESS OR IMPLIED BY LAW, COURSE OF DEALING, COURSE OF PERFORMANCE, USAGE OF TRADE OR OTHERWISE, INCLUDING THE IMPLIED WARRANTIES OF MERCHANTABILITY AND FITNESS FOR A PARTICULAR PURPOSE. Without limiting the generality of the foregoing, Qorvo® products are not warranted or authorized for use as critical components in medical, life-saving, or life-sustaining applications, or other applications where a failure would reasonably be expected to cause severe personal injury or death. Applications described in the Data Sheet Information are for illustrative purposes only. Customers are responsible for validating that a particular product described in the Data Sheet Information is suitable for use in a particular application.

© 2025 Qorvo US, Inc. All rights reserved. This document is subject to copyright laws in various jurisdictions worldwide and may not be reproduced or distributed, in whole or in part, without the express written consent of Qorvo US, Inc. | QORVO® is a registered trademark of Qorvo US, Inc.