

TQP7M9104 –2.3-2.4GHz Reference Design

Product Overview

The TQP7M9104 is a high linearity driver amplifier in industry standard, RoHS compliant, QFN surface mount package. This InGaP / GaAs HBT delivers high performance across 600 – 2700 MHz range of frequencies with 15.8 dB Gain, +49.5 dBm OIP3 and +32.5 dBm P1dB at 2.14 GHz while only consuming 435 mA quiescent collector current. All devices are 100% RF and DC tested.

The TQP7M9104 incorporates on-chip features that differentiate it from other products in the market. The amplifier integrates an on-chip DC over-voltage and RF over-drive protection. This protects the amplifier from electrical DC voltage surges and high input RF input power levels that may occur in a system.

The TQP7M9104 is targeted for use as a driver amplifier in wireless infrastructure where high linearity, medium power, and high efficiency are required. The device is an excellent candidate for transceiver line cards and high power amplifiers in current and next generation multicarrier 3G / 4G base stations.

Referenced Documents

The reference documents below take precedence over the contents of this application note and should always be consulted for the latest information.

TQP7M9104 Data Sheet.

APPLICATION NOTE: TQP7M9104 –2.3-2.4GHz Reference Design

Application Electrical Performance

Qorvo Field and Factory Applications Engineers are available to provide technical assistance for determining appropriate matching networks for a particular application.

Parameter	Conditions	Typical Value			Units
Frequency		2300	2350	2400	MHz
Gain		15.0	15.0	15.0	dB
Input Return Loss		16.5	16.0	15.6	dB
Output Return Loss		7.0	7.6	8.0	dB
Output P1dB		32.5	32.2	32.0	dBm
OIP3	Pout=+17 dBm/tone, $\Delta f=1$ MHz	44.0	43.4	43.5	dBm
WCDMA Channel Power	At -50 dBc ACLR	21.5	20.5	20.5	dB
Device Current, I _{DD}		435			mA

Test conditions unless otherwise noted: V_{cc} = +5V, Temp = +25°C, 50 Ω system.

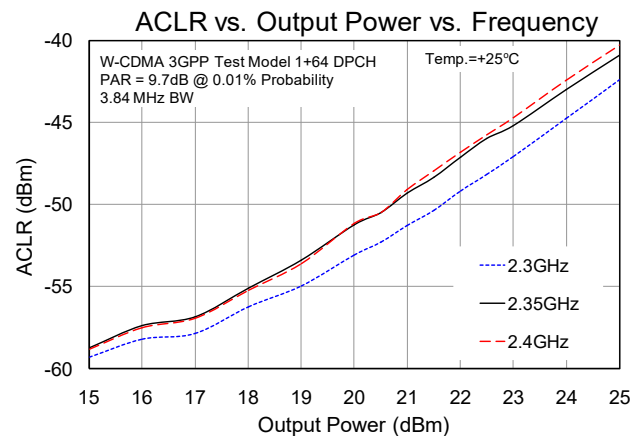
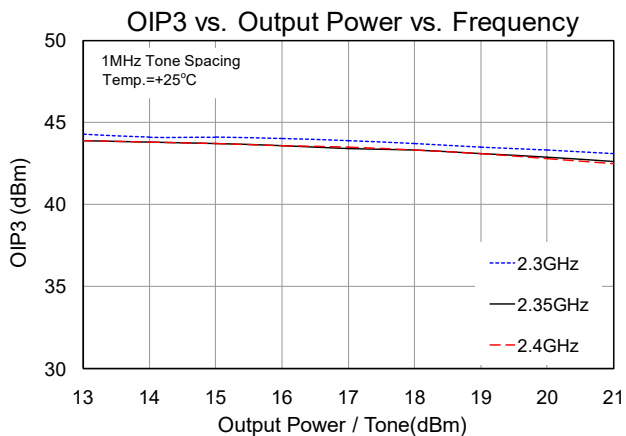
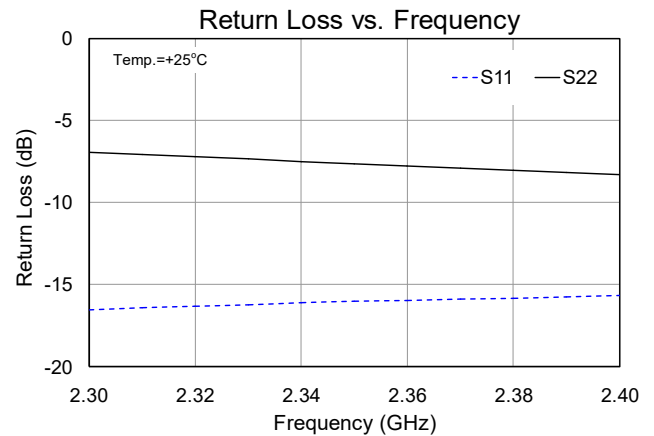
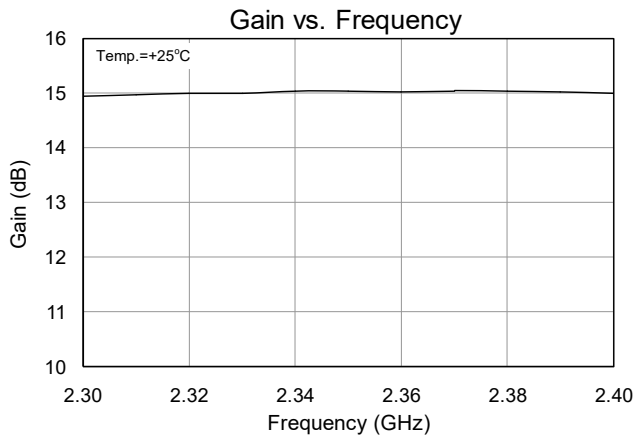

APPLICATION NOTE: TQP7M9104 –2.3-2.4GHz Reference Design

Evaluation Board Information

Evaluation Board and Schematic

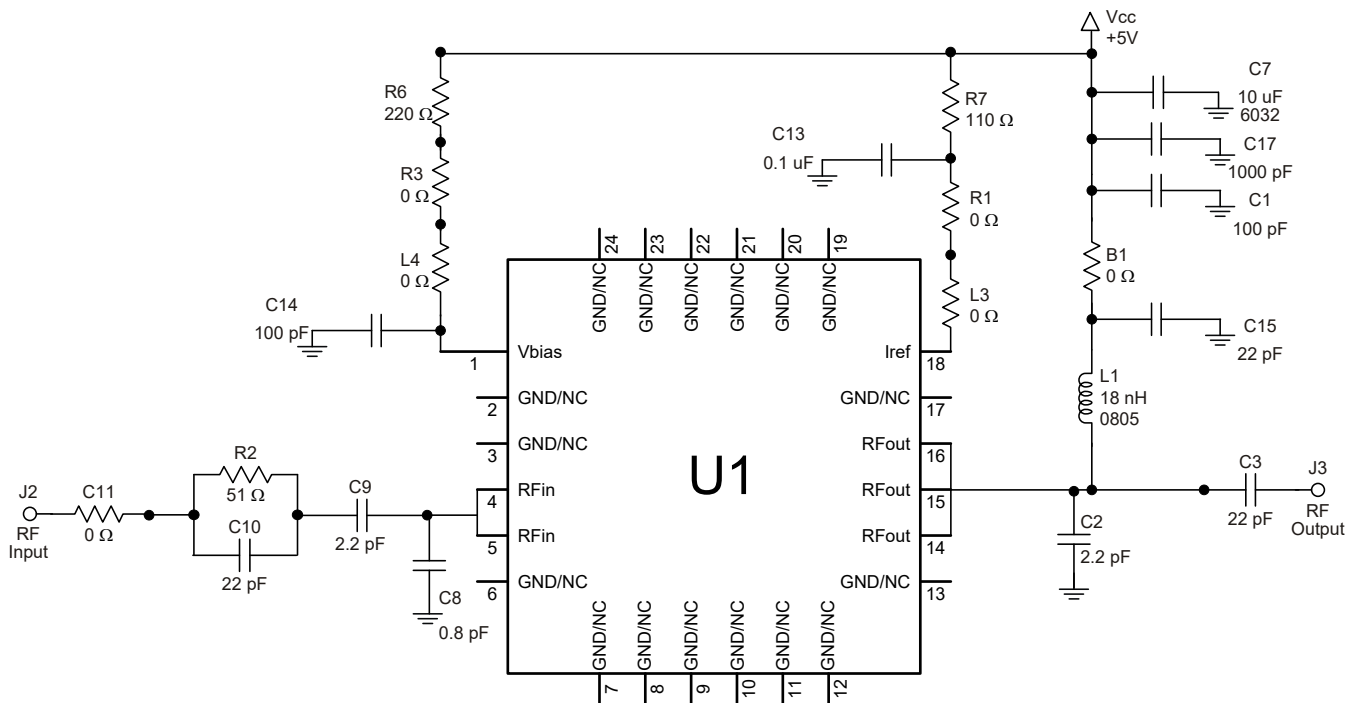
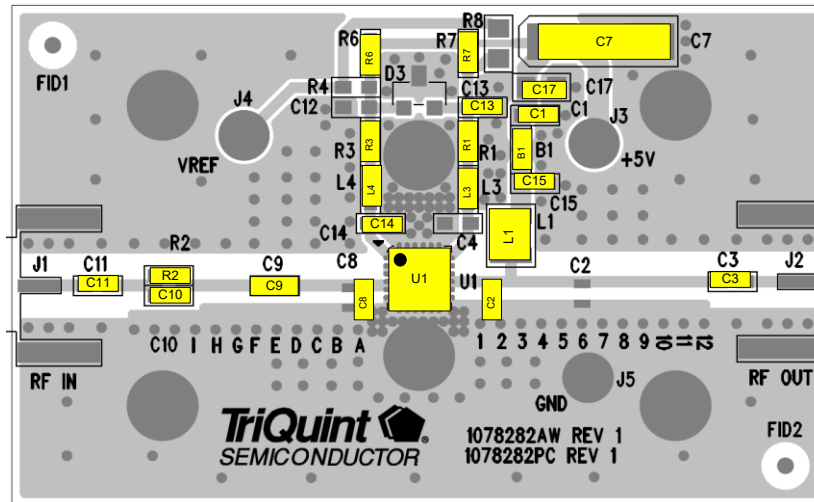

Notes:

1. See Evaluation Board PCB Information section for material and stack-up.
2. Critical component placement locations:
3. Distance between center of C8 and TQP7M9104 (U1) device package is 49 mil.
4. Distance between center of C2 and TQP7M9104 (U1) device package is 107 mil.
5. Distance between center of C9 and TQP7M9104 (U1) device package is 275 mil.

APPLICATION NOTE: TQP7M9104 –2.3-2.4GHz Reference Design

Evaluation Board – Bill of Material

Reference Des.	Value	Description	Manuf.	Part Number
n/a	n/a	Printed Circuit Board	Qorvo	
U1	n/a	2W High Linearity Amplifier	Qorvo	TQP7M9104
D3	n/a	Zener, dual, SOT-23	Various	
C8	0.8 pF	Capacitor, Chip, 0603, $\pm 0.05\text{pF}$, 50V, Accu-P	AVX	06035J1R5ABSTR
C2, C9	2.2 pF	Capacitor, Chip, 0603, $\pm 0.05\text{pF}$, 50V, Accu-P	AVX	06035J2R4ABSTR
B1, C11, L3, L4, R1, R3, R8	0 Ω	Resistor, Chip, 0603, 5%, 1/16W	Various	
C3, C10, C15	22 pF	Capacitor, Chip, 0603, 5%, 50V, NPO/COG	Various	
C1, C14	100 pF	Capacitor, Chip, 0603, 5%, 50V, NPO/COG	Various	
L1	18 nH	Inductor, 1008, 5%, Ceramic	Various	
L2	3.9 nH	Inductor, 0805, 5%		
C17	1000 pF	Capacitor, Chip, 0603, 10%, 50V, NPO/COG	Various	
C13	0.1 μF	Capacitor, Chip, 0603, 10%, 50V, X5R	Various	
C7	10 μF	Capacitor, Tantalum, 6032, 20 %, 50V	Various	
R2	51 Ω	Resistor, Chip, 0603, 5%, 1/16W	Various	
R6	220 Ω	Resistor, Chip, 0603, 1%, 1/16W	Various	
R7	110 Ω	Resistor, Chip, 0603, 1%, 1/16W	Various	
R4, C12, C4, D3	n/a	DNP	Various	

APPLICATION NOTE: TQP7M9104 –2.3-2.4GHz Reference Design

Additional Information

For information on ESD, Soldering Profiles, Packaging Standards, Handling and Assembly, please contact Qorvo for general guidelines.

Contact Information

For the latest specifications, additional product information, worldwide sales and distribution locations:

Web: www.qorvo.com

Tel: 1-844-890-8163

Email: customer.support@qorvo.com

Important Notice

The information contained in this Data Sheet and any associated documents (“Data Sheet Information”) is believed to be reliable; however, Qorvo makes no warranties regarding the Data Sheet Information and assumes no responsibility or liability whatsoever for the use of said information. All Data Sheet Information is subject to change without notice. Customers should obtain and verify the latest relevant Data Sheet Information before placing orders for Qorvo® products. Data Sheet Information or the use thereof does not grant, explicitly, implicitly or otherwise any rights or licenses to any third party with respect to patents or any other intellectual property whether with regard to such Data Sheet Information itself or anything described by such information.

DATA SHEET INFORMATION DOES NOT CONSTITUTE A WARRANTY WITH RESPECT TO THE PRODUCTS DESCRIBED HEREIN, AND QORVO HEREBY DISCLAIMS ANY AND ALL WARRANTIES WITH RESPECT TO SUCH PRODUCTS WHETHER EXPRESS OR IMPLIED BY LAW, COURSE OF DEALING, COURSE OF PERFORMANCE, USAGE OF TRADE OR OTHERWISE, INCLUDING THE IMPLIED WARRANTIES OF MERCHANTABILITY AND FITNESS FOR A PARTICULAR PURPOSE. Without limiting the generality of the foregoing, Qorvo® products are not warranted or authorized for use as critical components in medical, life-saving, or life-sustaining applications, or other applications where a failure would reasonably be expected to cause severe personal injury or death. Applications described in the Data Sheet Information are for illustrative purposes only. Customers are responsible for validating that a particular product described in the Data Sheet Information is suitable for use in a particular application.

© 2026 Qorvo US, Inc. All rights reserved. This document is subject to copyright laws in various jurisdictions worldwide and may not be reproduced or distributed, in whole or in part, without the express written consent of Qorvo US, Inc. | QORVO® is a registered trademark of Qorvo US, Inc.