

Add high-precision UWB RTLS to your product with an integrated module designed for fast integration and guaranteed interoperability.

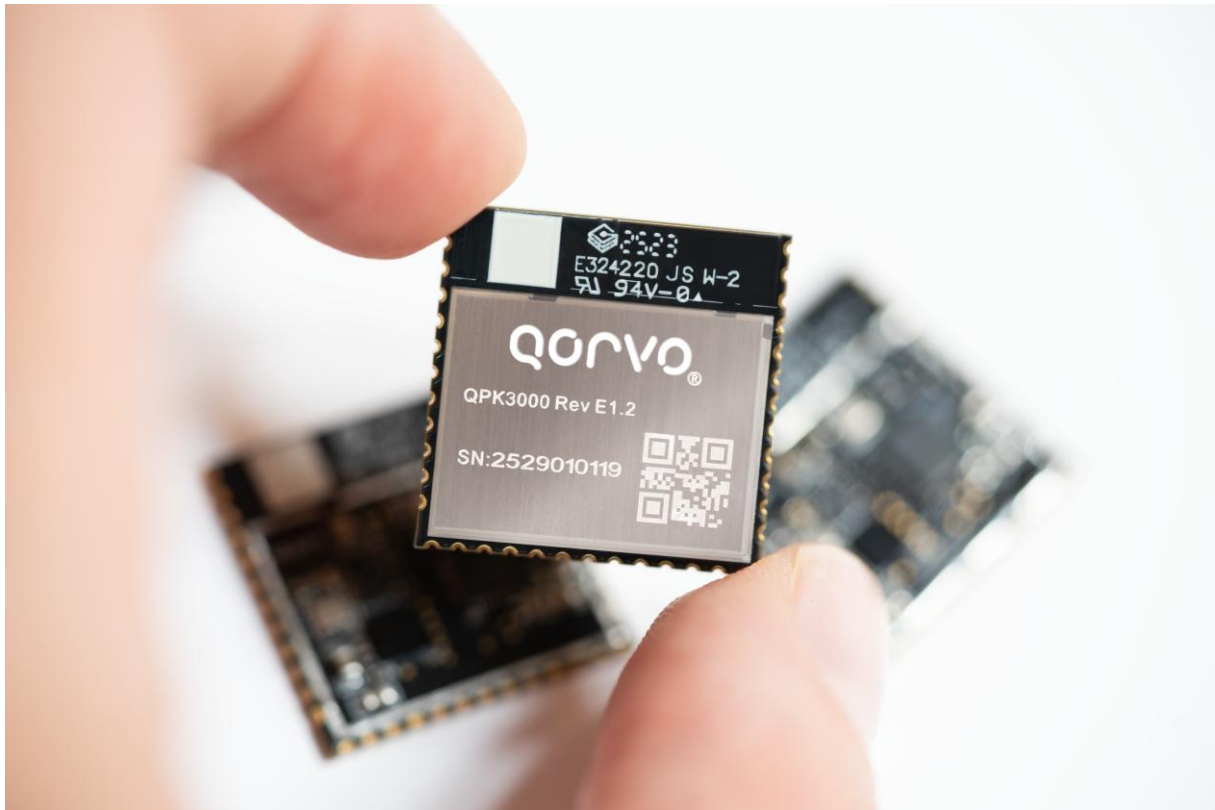

Applications

- **High-precision Real-Time Location Systems (RTLS)** and asset tracking using Uplink TDoA or Two-Way Ranging—enabling real-time visibility of assets and operations.
- **Last-meter positioning** (“Find My Asset”) using FiRa™ compliant UWB with Bluetooth LE for seamless user experiences. Following Apple Nearby Interaction Accessory Protocol and Android equivalent.
- **Location-aware wireless sensor networks**, combining communication and precise ranging in a single infrastructure.
- **Industrial positioning with omlox™ compliance**, ensuring interoperability across multi-vendor RTLS deployments.

Functional Block Diagram

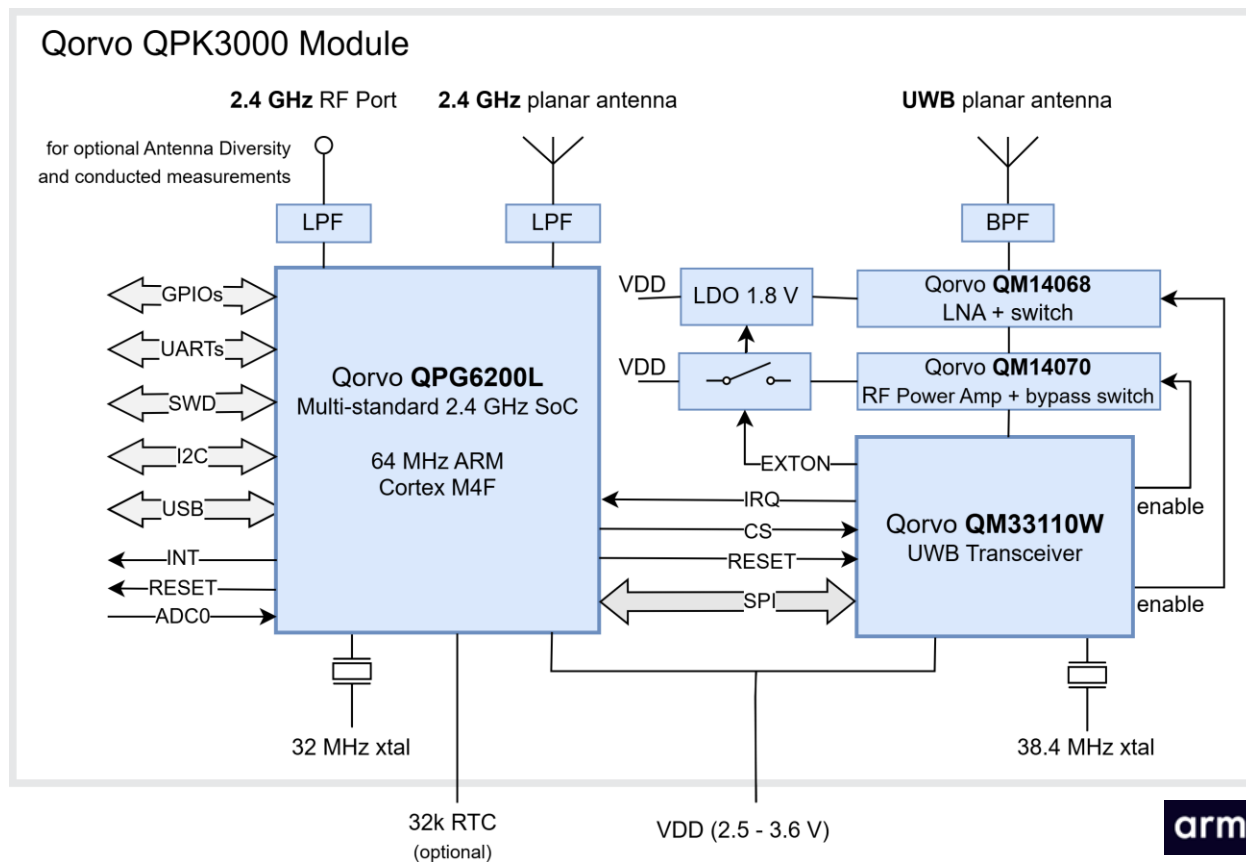

Product Overview

- Add UWB RTLS to new or existing products without redesign, reducing development time and complexity.
- Ensure interoperability with UWB-enabled enterprise infrastructure, including leading Access Points, for immediate ecosystem compatibility (Omlox and coming soon for Cisco Spaces).
- Develop custom or differentiated RTLS solutions using a flexible Zephyr-based software environment.
- Achieve reliable, high-performance wireless operation with a fully optimized, tested, and calibrated RF design.
- Enable multi-year battery-powered operation with optimized low power consumption.
- Support for TDoA and UWB Two-Way ranging architectures, giving flexibility in system design.
- Build FiRa™ compliant products to ensure interoperability across the growing UWB ecosystem.
- Enable Omlox-compliant industrial tag solutions for standardized, multi-vendor deployments.
- Accelerate certification timelines with pre-certified RF design: FCC (USA), ISED (Canada), ETSI (EU), listing pending.

Key Features

- IEEE 802.15.4z UWB BPRF compliant, enabling secure and precise ranging.
- Aligned with FiRa and omlox standards, allowing development of interoperable or proprietary RTLS solutions.
- Supports UWB channels 5 (6.5 GHz) and 9 (8 GHz), ensuring global deployment flexibility.
- Integrated Narrow-Band Multi-standard 2.4 GHz radio support (BLE and IEEE 802.15.4) for control, provisioning and hybrid use cases.
- High RF link budget and sensitivity, delivering robust performance in challenging environments.
- Optional +10 dB transmit power (EU indoor) to extend range and coverage where needed (per CEPT ECC/DEC/(06)04 amendment).
- Integrated antennas for UWB and 2.4 GHz, reducing design complexity and BOM effort.
- Optional antenna diversity, improving RX sensitivity by up to 8–12 dB for even more reliable connectivity.
- SESIP Level 2 Cybersecurity compliance, supporting secure IoT deployments.
- Compact 20 × 20 × 3.2 mm form factor, enabling easy integration into space-constrained RTLS Tag designs.
- Wide operating conditions (2.5–3.6 V, -40°C to +85°C) for industrial-grade applications.
- Castellated module (37 pins, 1.5 mm pitch) for simplified PCB integration and manufacturing.

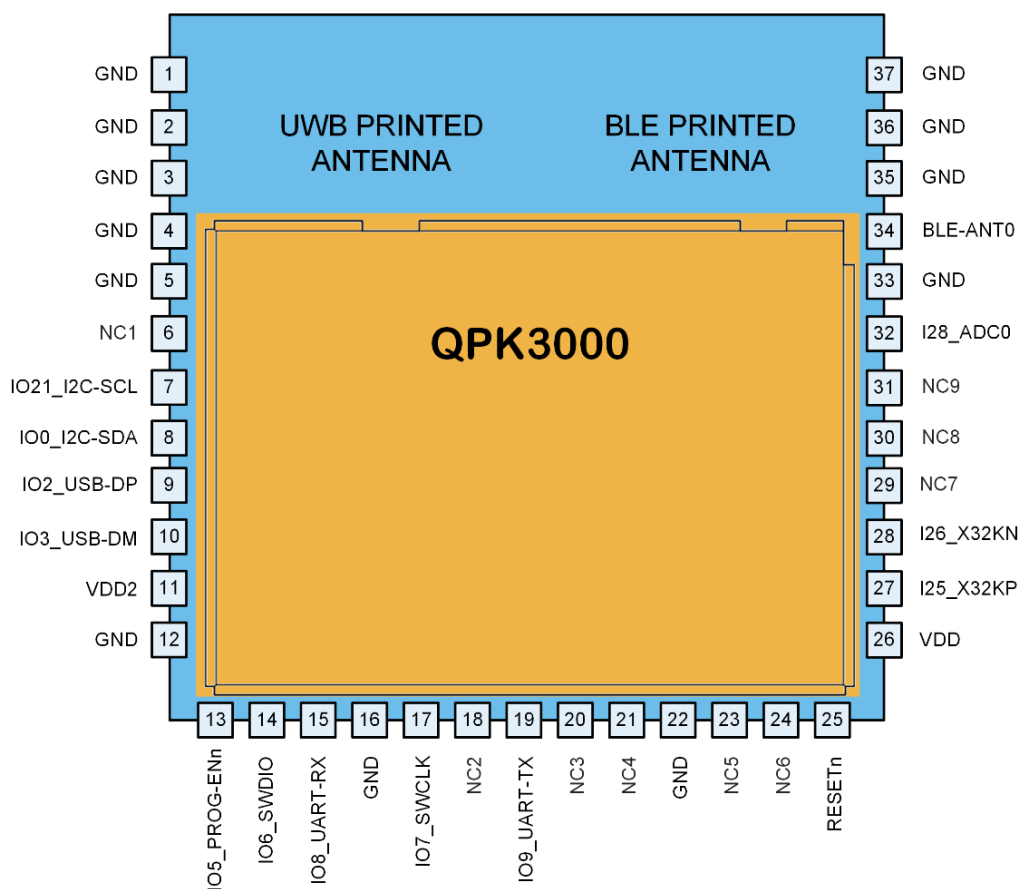

Figure 1: QPK3000 Pin-Out

Software Support

Flexible software options to match your development strategy:

- Zephyr-based SDK for full customization and differentiation
- Cisco Spaces software binary for rapid deployment of interoperable FiRa-based solutions
- omlox based software binary for standardized industrial RTLS deployments.

Please contact Qorvo for access and support details.

Mechanical Dimensions

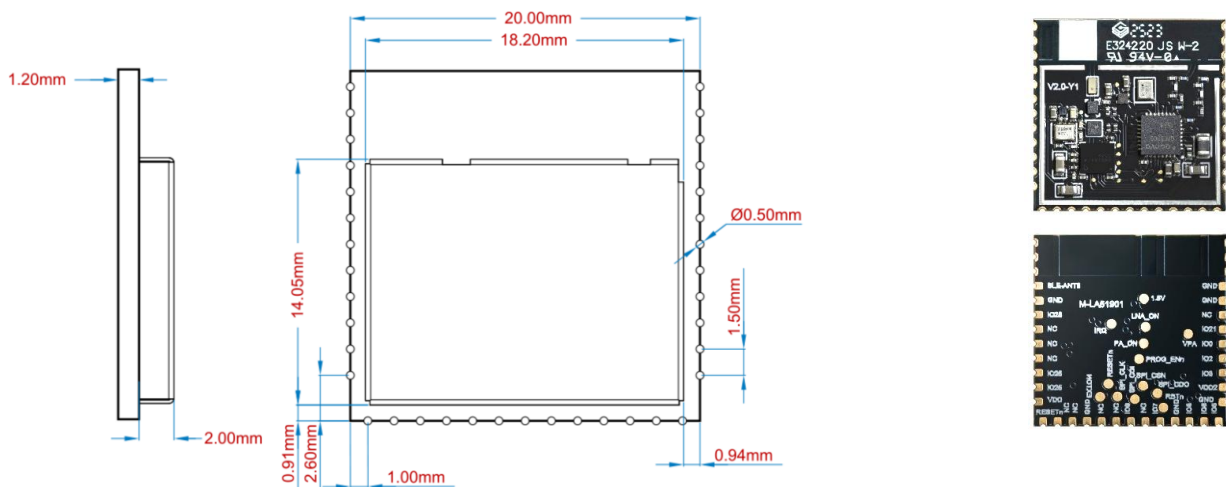

Figure 2: Mechanical Dimensions

Ordering Information

Part Number	Description
QPK3000TR13	RTLS Module with access to programmable SDK or FiRa-based software for Cisco Spaces, 500 pcs on 13" reel
QPK3000ATR13	RTLS Module with access to omlox-based software, 500 pcs on 13" reel

Contact Information

For the latest specifications, additional product information, worldwide sales and distribution locations:

Web: www.qorvo.com

Tel: 1-844-890-8163

Email: customer.support@qorvo.com

Revision History

Data Sheet Revision	Changes
A	Preliminary version.
B	Module height updated.
	Block diagram updated.
	Footers updated.
	Minor text and format updates.

Important Notice

The information contained herein is believed to be reliable; however, Qorvo makes no warranties regarding the information contained herein and assumes no responsibility or liability whatsoever for the use of the information contained herein. All information contained herein is subject to change without notice. Customers should obtain and verify the latest relevant information before placing orders for Qorvo products. The information contained herein or any use of such information does not grant, explicitly or implicitly, to any party any patent rights, licenses, or any other intellectual property rights, whether with regard to such information itself or anything described by such information.

THIS INFORMATION DOES NOT CONSTITUTE A WARRANTY WITH RESPECT TO THE PRODUCTS DESCRIBED HEREIN, AND QORVO HEREBY DISCLAIMS ANY AND ALL WARRANTIES WITH RESPECT TO SUCH PRODUCTS WHETHER EXPRESS OR IMPLIED BY LAW, COURSE OF DEALING, COURSE OF PERFORMANCE, USAGE OF TRADE OR OTHERWISE, INCLUDING THE IMPLIED WARRANTIES OF MERCHANTABILITY AND FITNESS FOR A PARTICULAR PURPOSE.

Without limiting the generality of the foregoing, Qorvo products are not warranted or authorized for use as critical components in medical, life-saving, or life-sustaining applications, or other applications where a failure would reasonably be expected to cause severe personal injury or death.

Copyright 2025 © Qorvo, Inc. | Qorvo is a registered trademark of Qorvo, Inc.

Qorvo is a registered trademark of Qorvo US, Inc. The Bluetooth® word mark and logos are registered trademarks owned by Bluetooth SIG, Inc. and any use of such marks by Qorvo is under license. FiRa, FiRa Consortium, the FiRa logo, the FiRa Certified logo, and FiRa tagline are trademarks or registered trademarks of FiRa Consortium or its licensor(s)/ supplier(s) in the US and other countries. omlox is a trademark of BeSpoon SAS. All other trademarks, service marks, and product or service names are trademarks or registered trademarks of their respective owners.

The module's color and marking is subject to change.