

qorvo

Reference Design Guide

QM35825 & ACT88329

DISCOVER THE QM35825

A compact powerhouse for modern connectivity, seamlessly integrating Qorvo's UWB with efficient and reliable power management.

APPLICATIONS

- Precision real time location systems (RTLS) using TWR, TDoA or AoA schemes
- Geofencing safety
- Secure access and payments
- Location aware controls and wireless sensor networks
- Low latency wireless data communications
- Radar applications

KEY BENEFITS

- Asset location to an accuracy of ± 5 cm and $\pm 2^\circ$ AoA
- High multipath fading immunity
- Secure ranging/distance measurement using scrambled time stamp (STS)
- Supports high tag densities in RTLS
- Low-cost precision location
- Suitable for coin cell applications

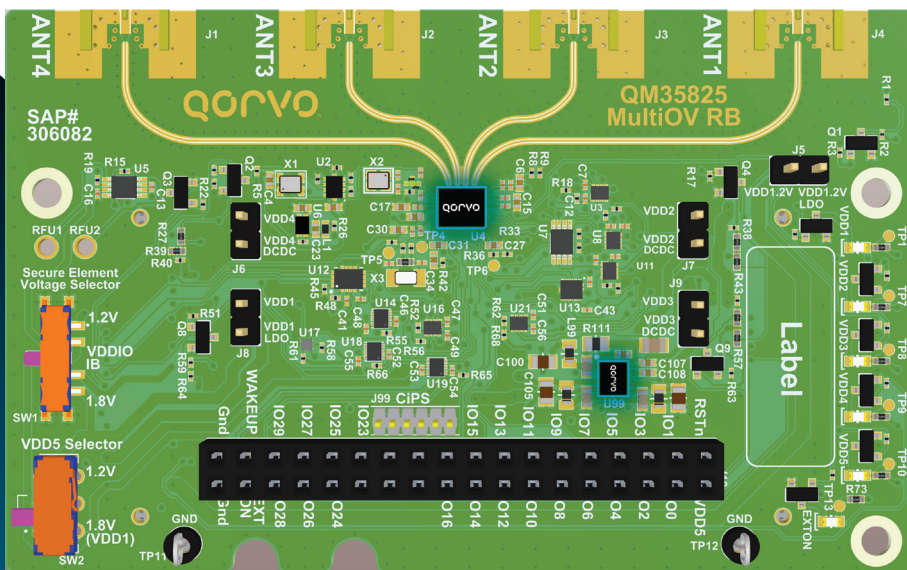

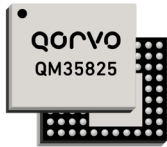

QM35825



LEARN MORE

The QM35825 SoC is a fully integrated UWB solution compliant with IEEE 802.15.4z™ - 2024.

KEY FEATURES

- Low power consumption
- Supports channels 5 and 9 (6489.6 MHz and 7987.2 MHz)
- Full support for 802.15.4z HRP, BPRF and HPRF modes
- Data rates of 850 kbps, 6.8 Mbps, 7.8 Mbps, 27.2 Mbps, 31.2 Mbps and 62.4 Mbps (proprietary)
- Features enhanced time-of-flight security modes
- Secure boot, secure debug, a secure enclave and HW crypto (RSA, SHA, AES, TRNG)

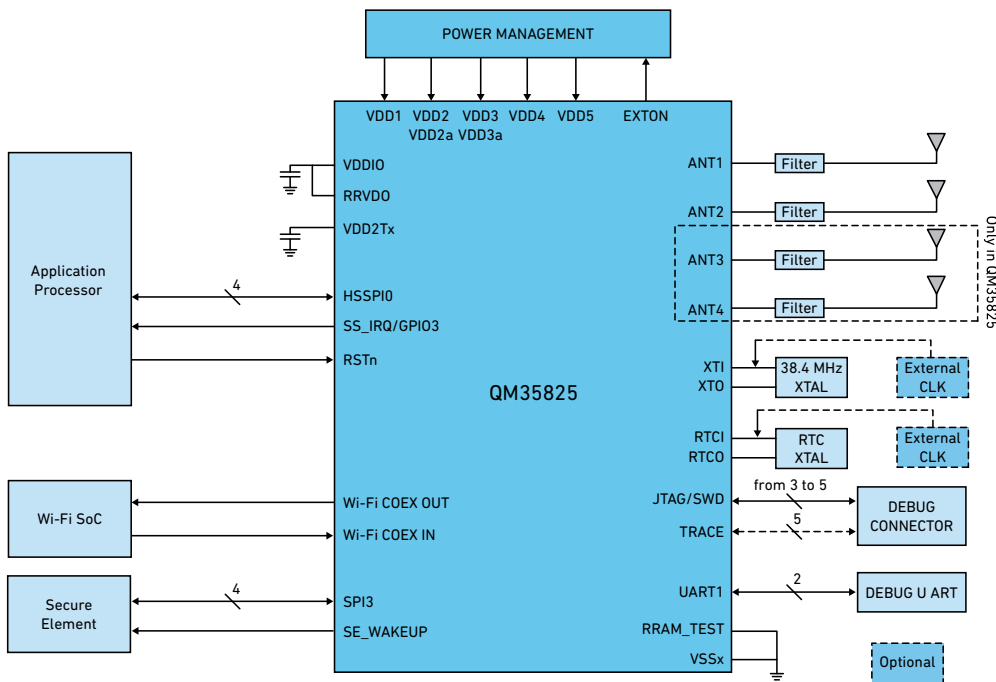



ACT88329



LEARN MORE

Qorvo® recommends the ACT88329 PMIC as the ideal choice for powering QM35825 applications, with its default configuration specifically optimized to meet the unique requirements of the QM35825 systems.

Benefits of Using ACT88329 to Power QM35825 UWB:

- **Single chip** power solution for efficient power delivery in complex systems
- **High integration** results in an extremely small PCB footprint and low BOM count
- **Low noise outputs** result in high system receiver sensitivity and low packet error rate
- **Configurability** allows easy output voltage changes to optimize system level power
- **Supports both 4-layer and 6-layer PCB stack-ups**, minimizing footprint while maximizing functionality
- **Orderable part number:** ACT88329VU101

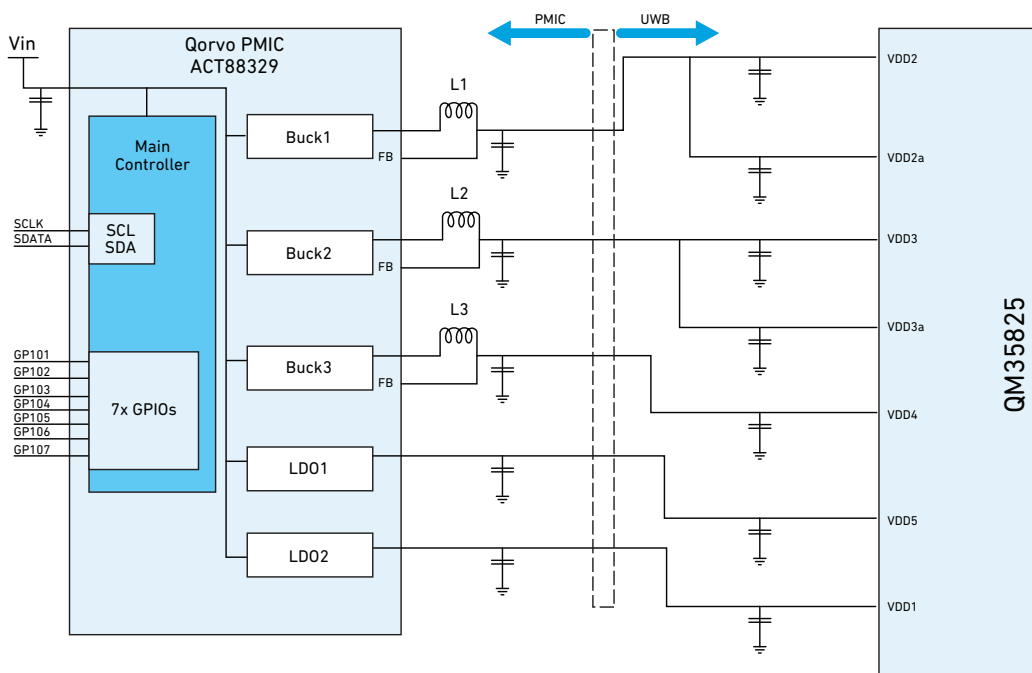

QM35825 + ACT88329

Sensitivity-tested PMIC solution that enables tuning of the QM35825 for optimal performance.

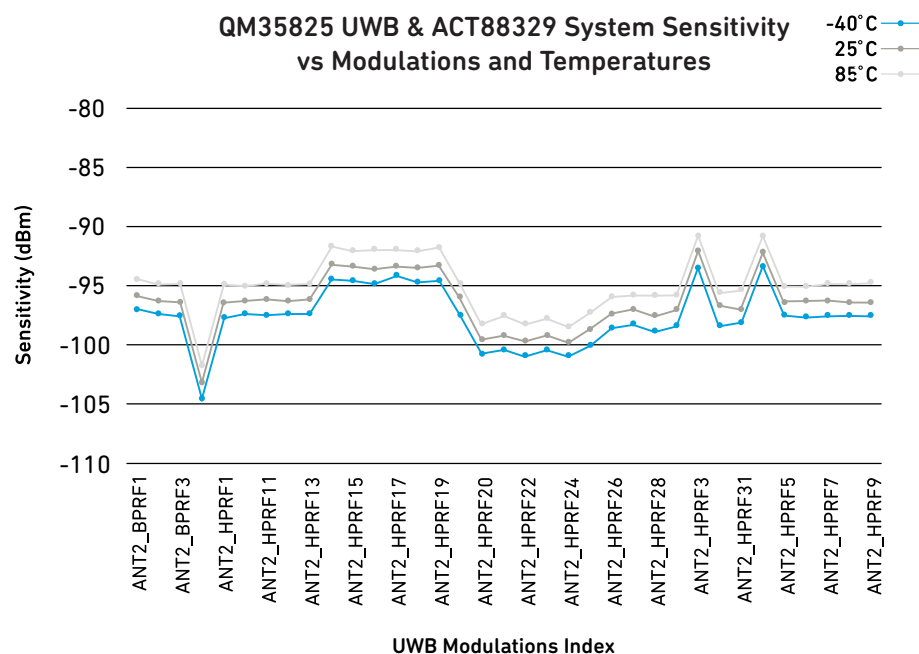

The table below compares the current draw from the battery of the two systems using different power solutions. The ACT88329 provides a 26% reduction in transmit battery current which translates to significant battery life improvement. Also, note the ACT88329's improved packet error rate (PER).

Power Solution	Max I_Battery Rx (mA)	Max I_Battery Tx (mA)	Sensitivity (dBm)	PER (%)
ACT88329	117	150	-96.5	0.9
Discrete	177	204	-96.6	1.0



EXPLORE FULL
REFERENCE DESIGN



qorvo®

© 12-2025 Qorvo US, Inc. | QORVO is a trademark of Qorvo US, Inc.
Other trademarks and trade names are those of their respective owners.