

High-Performance Defense and Aerospace Solutions

Industry's largest portfolio of MMICs,
beamformer ICs, discrete products, modules
GaN | GaAs | Si | SAW | BAW

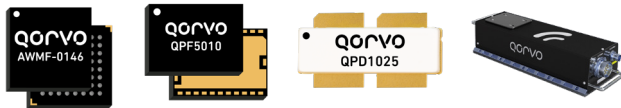

QORVO
all around you

Mission Critical Defense Applications (Signal Chains)

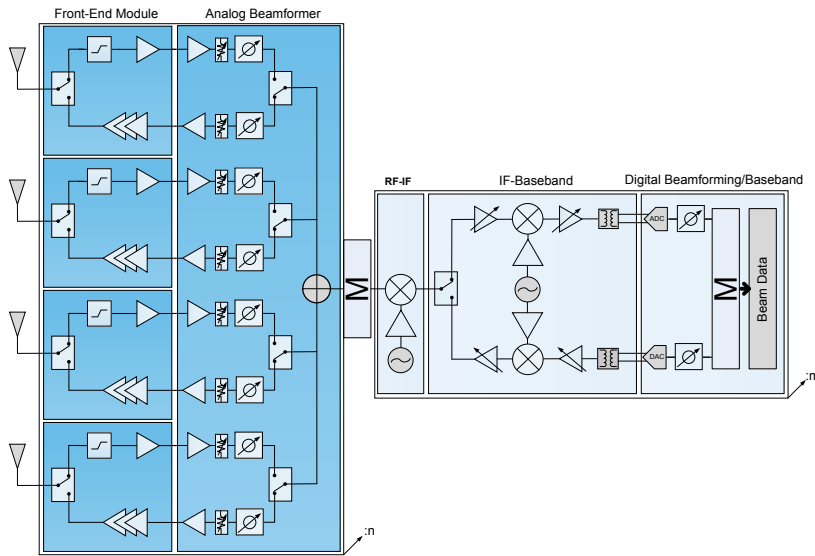

Radar (L, S, C, X, Ka-Band)

Today's advanced radar systems need to be more powerful and have greater functionality to detect a variety of growing global threats. Qorvo® has the largest portfolio of high-performance beamformer ICs, MMICs and discrete components designed for these applications. We can deliver the products and signal chain expertise you need to maintain the leading edge no matter in which frequency band you want to operate. Qorvo is in the unique position to provide our customers with unique features and differentiation over alternatives. By using silicon beamformer ICs that integrate all core beam steering and control functions coupled with our advanced GaAs/GaN T/R FEMs, customers can fit the RF front end within the radiating element lattice for tile X-band low-profile antennas that reduce SWaP-C and observability.

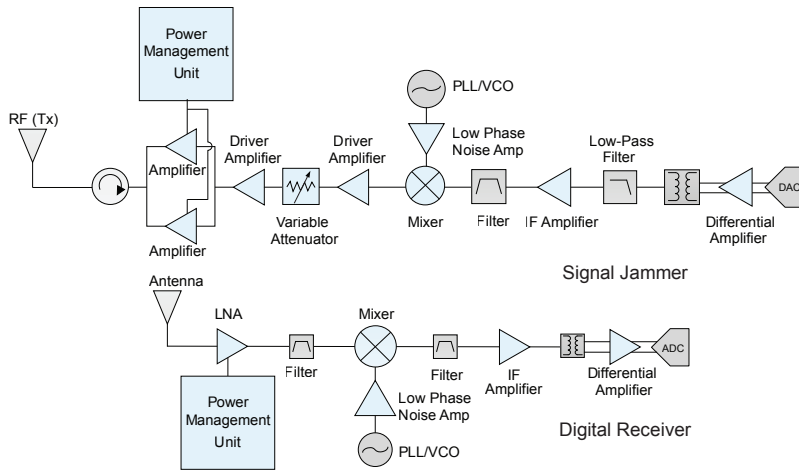

Electronic Warfare (EW)

Over the past decade there has been a greater emphasis given to EW technologies. EW supremacy is vital to maintaining the battlefield advantage.

Qorvo delivers wideband RF solutions for electronic warfare, with transmit amplifiers that combine output high power with high efficiency across multiple frequency bands. Our portfolio includes transmit and front-end functions in integration-ready modules designed to handle demanding RF conditions and continuous operation. The result is RF performance that meets system requirements while reducing design complexity.

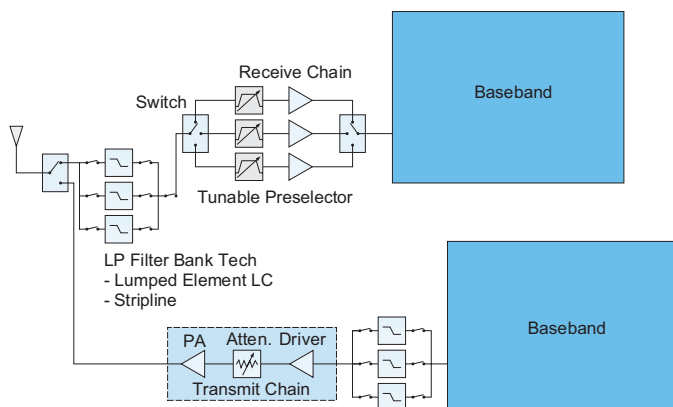

Communications

Secure and reliable communications are priority one in any potential conflict. Qorvo understands what it takes to maintain a reliable and secure wireless connection all the way from the antenna to the receiver. You can trust our products to keep the lines of communications open and working at maximum efficiency under any circumstances. Qorvo's beamforming and IF transceiver silicon ICs provide new options for higher levels of integration and high-performance phased array antennas.

X-Band Solutions

Higher Performance, Greater Choices, Lower Cost and Assured Availability

Qorvo provides the industry's most capable components for high performing X-band radars. Using silicon beamformer ICs that integrate all core beam steering and control functions coupled with advanced GaN T/R FEMs, customers can fit the RF front end within the radiating element lattice for planar X-band low-profile antennas that reduce SWaP-C and observability.

AWS-0103

High Linearity Beamformer IC

Silicon quad core beamforming IC with selectable dual Rx beams to support monopulse or dual polarization operation.

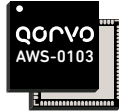

AWS-0101

Low Noise Figure Beamformer IC

Silicon quad core beamforming IC with selectable dual Rx beams to support monopulse or dual polarization operation.



QPF5002

2W T/R Module

Multi-die FEM with T/R switch, limiter, LNA and PA. Tx power = 2W, Rx NF = 2.1 dB.

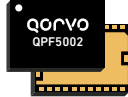

QPM1002

3W T/R Module

GaN MMIC integrated FEM with T/R switch, limiter, LNA and PA. Tx power = 3W, Rx NF = 2.2 dB.



QPF5005

5W T/R Module

Multi-die FEM with T/R switch, limiter, LNA and PA. Tx power = 5W, Rx NF = 2.2 dB.

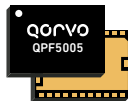

QPM2637

4W T/R Module

GaN MMIC integrated FEM with T/R switch, limiter, LNA and PA with dual Rx outputs. Tx power = 4W, Rx NF = 2.7 dB.

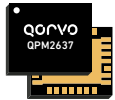

QPF5010

10W T/R Module

Multi-die FEM with T/R switch, limiter, LNA and PA. Tx power = 10W, Rx NF = 2.2 dB.

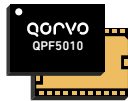

QPF5001

12W T/R Module

Multi-die FEM with limiter, LNA and PA. Interfaces to circulator. Tx power = 12W, RF NF = 1.4 dB.

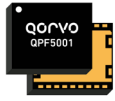

QPF5012

10W T/R Module

Multi-die high efficiency FEM with T/R switch, limiter, LNA and PA. Tx power = 10W, Rx NF = 2.1 dB.



AWMF-0106

Dual Rx Beam Front-End IC

Integrated PA, LNA, T/R switch, limiter.

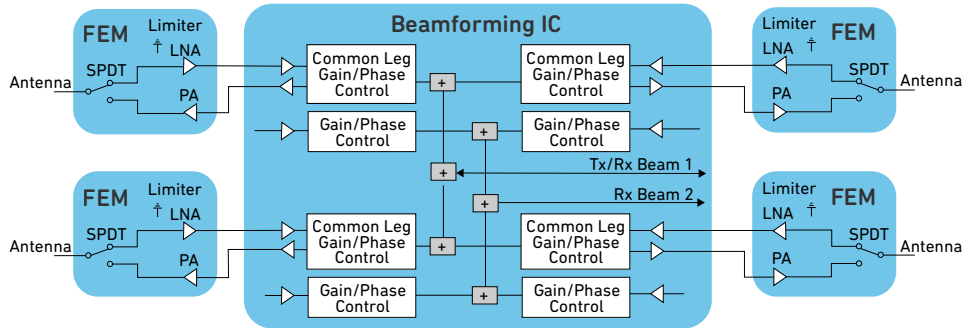
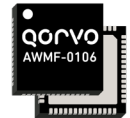

Fine-Tune Your X-Band Radar with These Components



QPC2040 8-12 GHz
GaN 10W SPDT
IL < 1.2 dB
3x4.5mm QFN



QPP0100 8-11.5 GHz
VPIN 100W Limiter
IL < 1 dB
4x4mm QFN



CMD319C3 8-12 GHz
Ultra Low NF LNA
NF < .92 dB
3x3mm QFN

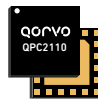

QPC2110 8-12 GHz
SOI Phase Shifter
IL < 8 dB
RMS Phase Error < 3°
2x2mm QFN



CMD253C3 6-14 GHz
Diode Mixer
IF = DC-5 GHz
Conv. Loss = 6 dB
3x3mm QFN

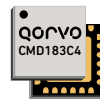

CMD183C4 7.5-13 GHz
I/Q Mixer
IF = DC-4.5 GHz
Conv. Loss = 5.5 dB
4x4mm QFN



QPM5811 8.5-10.5 GHz
0.5W T/R FEM, PAE 45%
30 dB Tx Gain
26 dB Rx Gain
6x6mm QFN

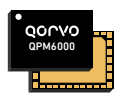

QPM6000 8-14 GHz
100W Limiter/LNA
Best robustness
70% PCB area reduction
8.5x6mm QFN



QPL3050 6-14 GHz
GaAs Driver Amplifier
P1dB = 20 dB
Gain = 19 dB
3x3mm QFN



CMD245C4 6-18 GHz
GaAs Low Phase Noise Amplifier
Psat = 22 dBm
Phase Noise = -165 dBc/Hz
4x4mm QFN

Visit qorvo.com/go/xradar to see our complete portfolio.

Highly Integrated mmWave RF-to-Digital Solutions for Phased Array Active Antennas

Qorvo's innovative portfolio of active antenna ICs provides new options for higher integration and high performance that will democratize phased array active antennas. Our portfolio enables a unique combination of innovation + commercial scale + reputation to deliver with proven commercial success across mmWave, SATCOM, D&A and 5G markets.

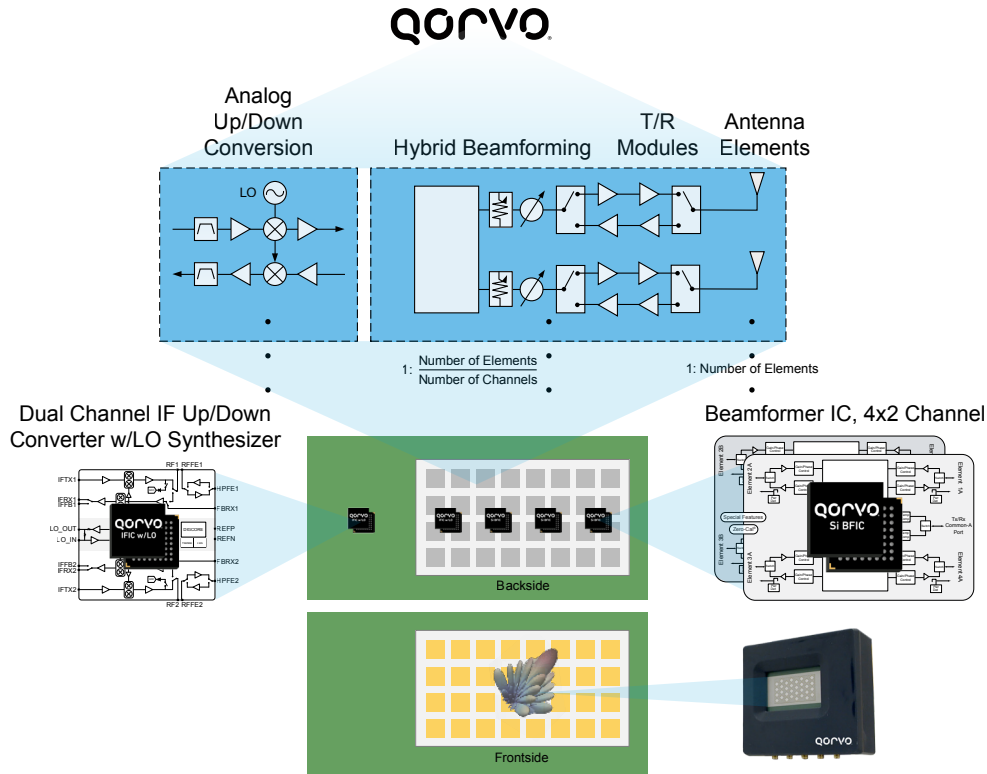

Benefits of mmWave Si Technology:

- Lowest \$/dBm commercially available today
- Multi-band performance
- Advanced digital core simplifying design
- Smart integration
- Complete signal chain solutions (IQ, IF, RF, mmW, antennas, algorithms)
- Scalable quad architecture
- Zero-Cal[®] reduces calibration
- System level support for optimized solutions
- 300 mm CMOS for lowest cost
- Proven in volume in fielded radios

Applications:

- Military/commercial radar
- SATCOM LEO/MEO, GEO
- mmWave 5G
- Future FR3

Featured Products

Market	IC Type	Frequency (GHz)	Feature	Part Number
RADAR	Tx/Rx Beamformer IC	8.5 to 10.55	Single Tx, Dual Rx	AWS-0103
RADAR	Tx/Rx Beamformer IC	8.5 to 10.55	Single Tx, Dual Rx	AWS-0101
SATCOM	Rx Beamformer IC	10.7 to 12.75	4x2 Dual Pol	AWMF-0146
SATCOM	Rx Beamformer IC	10.7 to 12.75	4x2 Dual Pol	AWMF-0240
SATCOM	Tx/Rx Beamformer IC	Rx: 10.7 to 12.75; Tx: 13.75 to 14.5	4x1 Tx/Rx TDD	AWMF-0247
SATCOM	Tx Beamformer IC	13.75 to 14.5	4x2 Dual Pol	AWMF-0147
SATCOM	Tx Beamformer IC	13.75 to 14.5	4x2 Dual Pol	AWMF-0241
SATCOM	Rx Beamformer IC	17.7 to 21.2	4x2 Dual Pol	AWMF-0197
SATCOM	Rx Beamformer IC	17.7 to 21.2	4x2 Dual Pol	AWMF-0238
mmW 5G	Tx/Rx Beamformer IC	24 to 30	4x2 Dual Pol	AWMF-0221
mmW 5G	IF Up/Down Converter IC	24 to 30	Single Channel; Wideband	AWMF-0210
mmW 5G	IF Transceiver IC	24 to 30	Dual Channel; Wideband	AWMF-0224
All Markets	32-Element mmW-IF Antenna	24 to 30	4x2 Dual Pol	AWA-0213
SATCOM	Tx Beamformer IC	27.5 to 31	4x2 Dual Pol	AWMF-0198
SATCOM	Tx Beamformer IC	27.5 to 31	4x2 Dual Pol	AWMF-0239
mmW 5G	Tx/Rx Beamformer IC	37 to 43.5	4x2 Dual Pol	AWMF-0236
mmW 5G	IF Up/Down Converter IC	37 to 43.5	Single Channel; Wideband	AWMF-0218
mmW 5G	IF Transceiver IC	37 to 48.2	Dual Channel; Wideband	AWMF-0196

Gallium Nitride (GaN) Innovation

With high-performance GaN technology, Qorvo continues to build on its strong GaAs legacy through innovative products and Elite360SM Foundry & Services. Through the Elite360 platform, customers gain access to trusted U.S.-based manufacturing, advanced packaging and proven GaN expertise to meet demanding performance requirements through MRL10-qualified manufacturing and a secure, reliable supply chain.

The GaN Advantage

Qorvo GaN technology delivers industry-leading power density, efficiency and reliability, helping designers meet challenging SWaP-C requirements. By enabling higher performance in a smaller footprint, Qorvo GaN supports more capable RF systems while reducing overall system costs.

Key Qorvo GaN attributes:

- >65 million device hours on 16,900 devices in the field, with less than 0.013% failures per million hours
- Proven reliability at high junction temperatures, mean time to failure (MTTF) of greater than 10^7 (10 million) to 10^9 (1 billion) hours at 200 degrees (C) and greater than 10^6 (1 million) to 10^8 (100 million) hours at 225 degrees (C)
- Production technologies supporting DC through Ka-band
- Excellent noise figure – comparable to pHEMT
- Highly robust to ESD and RF input signals
- SiC substrates for superior thermal management
- High power density (Improved SWaP)
- High power-added efficiency (Improved SWaP)

GaN Foundry Processes

As a DoD-accredited 'Microelectronics Trusted Source', Qorvo offers a variety of GaN technologies for optimized solutions. Accreditation encompasses foundry, post-processing, packaging/assembly and test services. Support provided by our foundry services division complements Qorvo's high-frequency standard product portfolio.

QGaN25:

- Technology: 0.25 μ m GaN on SiC
- Drain bias (Vd): up to 40V
- Operating frequencies: DC-18 GHz
- PAE: >60% at 10 GHz
- Power density: 6W/mm at 10 GHz
- Reliability: >10M hours at 200 degrees (C) and 40V (3-temp DC MTTF with failure defined as 10% degradation in Idmax)

QGaN15:

- Technology: 0.15 μ m GaN on SiC
- Drain bias (Vd): up to 28V
- Operating frequencies: DC-40 GHz
- PAE: >50% at 30 GHz
- Power density: 4.2W/mm at 30 GHz
- Reliability: >10M hours at 200 degrees (C) and 28V (DC MTTF with failure defined as 10% degradation in Idmax)

QGaN25HV:

- Technology: 0.25 μ m GaN on SiC
- Drain bias (Vd): up to 48V
- Operating frequencies: DC-12 GHz
- PAE: >78% at 3.5 GHz
- Power density: 6.5W/mm at 3.5 GHz
- Reliability: >10M hours at 200 degrees (C) and 48V (3-temp DC MTTF with failure defined as 10% degradation in Idmax)

QGaN50:

- Technology: 0.50 μ m GaN on SiC
- Drain bias (Vd): up to 65V
- Operating frequencies: DC-8 GHz
- PAE: >78% at 3.5 GHz
- Power density: 9W/mm at 3.5 GHz
- Reliability: >10M hours at 200 degrees (C) and 65V (DC MTTF with failure defined as 10% degradation in Idmax)

GaN and GaAs Standard Products

Qorvo delivers high-performance GaN solutions with advanced packaging that optimizes thermal management and cost efficiency. Our GaN products are available in a range of Cu-based packages, from robust bolt-down designs to compact surface-mount options in air-cavity or overmold formats. As a leader in GaAs and GaN technology, Qorvo provides a growing portfolio of amplifiers, switches, and high-performance transistors for next-generation military and commercial applications. With rigorous testing and finite element analysis to ensure exceptional reliability and thermal performance, Qorvo is your trusted partner for high-volume GaN manufacturing.

Qorvo has always been recognized as the industry leader in GaAs design and manufacturing. Our portfolio includes virtually every RF function block in a complete signal chain making Qorvo the leader in GaAs MMIC solutions.

Explore our product selection tables to find the perfect product(s) for your next RF design or go to www.qorvo.com and use our easy-to-use parametric search tool to help speed your search and selection.

Integrated Front-End Modules

Description	Freq. Min (MHz)	Freq. Max (GHz)	Tx Gain (dB)	Tx Voltage (V)	Rx Gain (dB)	Rx NF (dB)	Rx Voltage (V)	Package (mm)	Part Number
2-18 GHz 10W	2	18	13	22	14	4	5	8x8	QPF0219
2-18 GHz 2W	2	18	15	18	16	4	5	7x6.5	QPA0218
8-12 GHz 12W	8	12	23	24	26	1.5	1.8	6x5	QPF5001
8.5-10.5 GHz 10W	8.5	10.5	20	22	23	2.1	1.8	7x5	QPF5012
8-12 GHz 10W	8	12	22	24	25	2.2	1.8	7x5	QPF5010
8-12 GHz 5W	8	12	24	24	25	2.2	1.8	7x5	QPF5005
8.5-10.5 GHz 2W	8.5	10.5	20.5	20	24	2.1	1.8	7x5	QPF5002
8.5-10.5 GHz 3.2W GaN	8.5	10.5	33	25	25	2.2	10	5x5	QPM1002
9-10.5 GHz 4W GaN	9	10.5	23	28	21	2.7	10	6x5	QPM2637
15.2-18.2 GHz 2W	15.2	18.2	25	20	25	2.6	3.5	6.5x5	QPF1418
8-14 GHz LNA with Limiter	8	14	-	-	23	1.6	2	8.5x6	QPM6000
2-20 GHz LNA with Limiter	2	20	-	-	17	1.7-4	5	6.5x5	QPM1000
8-12 GHz 0.5W	8.5	10.5	30	6	26	2	6	6x6	QPM5811
2-4 GHz Rx Core	2.5	4	-1.2	3.3	30	1.2	3.3	7x7	QPM2101
37 GHz FEM (Dual Channels)	37	40.5	23	20	18	4.2	20	4.5x6	QPF4005

Low Phase Noise Amplifiers

Frequency (GHz)	Phase Noise	Gain (dB)	OP1dB/Psat (dBm)	OIP3 (dBm)	Bias Voltage (V)	Bias Current (mA)	Package (mm)	Part Number
DC-18	-165	14.4	0/24	34	5/3	180	Die	CMD326
DC-26.5	-165	16	18-20.5	29	+3-5/+3	74	4x4/Die	CMD275P4/CMD275
DC-40	-165	11.1	0/21.4	31	5/3	100	Die	CMD327
2-20	-165	15	19-22	30.5	+3-5/+3	82	4x4	CMD274P4
6-18	-165	18	18-22	29	+3-5/+3	76	4x4/Die	CMD245C4/CMD245
8-22	-165	17	18-18	25	+3-5/+3	48	4x4/Die	CMD246C4/CMD246
30-40	-160	13	13.5/15	21	+2-4/+3	28	Die	CMD247

Low Noise Amplifiers

Frequency (GHz)	Gain (dB)	NF (dB)	OP1dB (dBm)	OIP3 (dBm)	Voltage (V)	Current (mA)	Package (mm)	Part Number
2-6	31	1.6	12	23	3-5	45	4x4/Die	CMD308P4/CMD308
2-6	27	0.6	16	26	2-5/1.5	42	3x3/Die	CMD283C3/CMD283
2-18	17	2	17	29	5	75	Die	TGA2525
2-20	17	2	19	29	5	100	4x4	TGA2567-SM
2-22	15	2	>23	-	8	125	4x4	TGA2227-SM
4-8	15.5	1.8	17	30	3-5	60	3x3/Die	CMD270P3/CMD270
5-11	27	1.5	13	23	3-5	45	4x4/Die	CMD309P4/CMD309
5-11	23	1.4	11	23	2-4.5	35	3x3/Die	CMD263P3/CMD263
6-11	20	1.8/2	16.5	27	3-5	66	3x3/Die	CMD271P3/CMD271
6-18	26	1.7/1.6	11	24/27	2-4.5	63	3x3/Die	CMD264P3/CMD264
6-18	27	1.4	12	24	3	52	3x3/Die	CMD328K3/CMD328
6-20	21	2.0	15	25	3-5.0	100	3x3/Die	CMD316C3/CMD316
7-14	26/27	1.1	18	-	3.5	120	4x4/Die	QPA2609/QPA2609D
8-11	27	1.7	9	15	10	20	4x4	QPL1000
8-12	20	0.92	16	22	3	30	3x3	CMD319C3
8-16	17	2.0	12	25	2-4	55	3x3/Die	CMD307P3/CMD307
10/10.5-13/12.7	16/17	1.2/1.1	-1.2/1	8	2	11	3x3/Die	QPL2210/QPL2210D
10.7-12.7	18	1.07	16	23	3	32	3x3	CMD320C3
13-20	26	1.1/1.2	18	-	3.5	105	4x4/Die	QPA2735/QPA2735D
17-22	25	1.3	20	28	3.5	90	4x4	QPA2626
17-25	27	1.4	8	17	3/1.5	27	4x4/Die	CMD298C4/CMD298
18-40	17	3.5	8	17	3/3	33	4x4/Die	CMD299K4/CMD299
22/25-32/31	23/22	1.6/1.7	19	27	3.5	90	4x4/Die	QPA2628/QPA2628D

Power Amplifiers

Description	Frequency (GHz)	Psat (dBm)	LS Gain (dB)	PAE (%)	Bias (Vdc)	Package (mm)	Part Number
10W Wideband PA	0.03-2.5	40	13	55	32	4x4 QFN	QPA2237
10W Wideband PA	0.1-3	41	13	40	40	4x4 AC-SMT	TGA2976-SM
18W Wideband PA	1-6	42.7	24	40	22	5x6 AC-SMT	QPA0106
35W Wideband PA	1-6	45.4	22.4	41	24	15x15 Flange	QPM0106
10W Wideband PA	1-8	40	15	30	28	5x6 AC-QFN	QPA1003P
1.6W Wideband PA	2-6	32	14	38	25	4x4 QFN	QPA2597
30W Wideband PA	2-6	45	22	30	28	15x15 Flange	TGA2578-CP
2.5W Wideband PA	2-20	34	16	23	18	4.5x4.5 AC-SMT	QPA2213
10W Wideband PA	2-20	40	13	22	22	5x5 AC-SMT	QPA2962
20W Wideband PA	2-20	44	16	23	22	15x15 Flange	QPA2966
45W Wideband PA	2.5-6	46.5	20	36	30	Flange	TGA2576-2-FL
2W S-Band PA	2.7-3.5	33	17	52	25	4x4 QFN	QPA2935
12W S-Band PA	2.7-3.5	41	25	52	28	5x5 QFN	TGA2975-SM
100W S-Band PA	2.7-3.5	50	25	53	30	7x7 QFN	QPA3069
50W S-Band PA	2.9-3.2	48.8	21.8	62	28	7x7 QFN	QPA2933
60W/50V S-Band PA	2.8-3.5	48	22	55	50	6x6 QFN	QPA1027
150W/50V S-Band PA	2.9-3.5	52	28	58	50	7x7 QFN	QPA3070
10W C-Band PA	4.5-7	40	19	40	22	5x5 QFN	QPA1019
4W S-Band PA	5-6	36.5	18	53	25	4x4 QFN	QPA0506
50W/50V C-Band PA	5-6	48	23	49	50	7x7 QFN	QPA2310
100W/50V C-Band PA	5-6	50	22	47	50	7x7 QFN	QPA2309
50W C-Band PA	5.3-5.9	47	21	50	30	6x6 QFN	QPA2311
100W C-Band PA	5.7-7	50	20	38	26	19x19 Flange	QPM1017
2.5W Wideband PA	6-12	34	16	30	22	4x4 QFN	QPA2598
30W C/X-Band PA	6-12	45	22	30	20	15x15 Flange	TGA2590-CP
10W Wideband PA	6-18	40	20	20	20	Die	QPA1013D
20W Wideband PA	6-18	43	18	20	20	15x15 Flange	TGA2963-CP
100W X-Band PA	7.9-11	50	22	35	28	19x19 Flange	TGM2635-CP
5W X-Band PA	8-12	38	26	42	24	5x5 QFN	QPA2611
12W X-Band PA	8-12	41	23	40	24	5x5 QFN	QPA2612
2W X-Band PA	8.5-10.5	33	23	47	20	5x5 QFN	QPA2610
2W X-Band PA	8.5-10.5	33	27	50	16	4x3 QFN	QPA0001
30W X-Band PA	8.5-10.5	45	30	45	22	6x6 QFN	QPA1111
60W X-Band PA	8.5-10.5	48.9	28	48.5	24	7x7 QFN	QPA2811
100W X-Band PA	10-12	50	22	26	28	19x19 Flange	QPM1021
16W X-Band PA	10.7-12.7	43	16	33	20	6x5 AC-SMT	QPA1009
35W X-Band PA	10.7-12.7	46	17	40	20	Die	QPA1006D
8W Ku-Band	12.75-15.35	39	29	32	24	7x4.5 AC-SMT	QPA0015
15W Ku-Band	12.75-15.35	42	28	32	24	7.5x5 AC-SMT	QPA0016
25W Ku-Band	12.75-15.35	44	31	35	24	7.5x6 AC-SMT	QPA0017
55W Ku-Band PA	12.75-15.35	47.5	22.5	37	24	Die	QPA1314D
50W Ku-Band PA	12.75-15.35	47	22	35	24	15x15 Flange	QPA1314
80W Ku-Band PA	13-15.5	49	24	25	28	19x19 Flange	QPM2239
2.5W Ku-Band PA	14.5-18.2	34	18	35	22	4x4 QFN	QPA0002
35W Ku-Band PA	15.4-17.7	45.5	21	20	26	15x15 Flange	QPA1315
20W K-Band PA	17.3-21.2	43	16	27	20	7.5x6 AC-SMT	QPA1724
20W K-Band PA	17.3-21.2	43	23	25	20	8.5x5.5 AC-SMT	QPA1725
10W K-Band PA	17.7-20.2	40	18	35	20	6x5 AC-SMT	QPA1722
2W Ka-Band	20-40	33	13	14	18	Die	QPA2040D
8W Ka-Band	20-40	39	12	12	18	Die	QPA2640D
5W Ka-Band	24.25-26.5	37	17	23	20	5x5.5 AC-SMT	QPA0524
5W Ka-Band	26.5-29.5	37	22	32	20	5x5 AC-SMT	QPA4003
10W Ka-Band PA	27.5-31	41	24	26	22	15x15 Flange	QPA2211
14W Ka-Band PA	27.5-31	42	24	26	22	Die	QPA2215D
20W Ka-Band PA	27.5-31	43	22	22	22	15x15 Flange	QPA2212
0.4W Ka-Band PA	28-38	26	12	14	20	4x3 AC-SMT	QPA2225
3W Ka-Band PA	32-38	35	12	16	6	7x8 AC-SMT	QPA2575
10W Ka-Band PA	32-38	40	16	22	24	Die	TGA2222
4W Q-Band PA	37.5-42.5	36	14	25	24	Die	QPA4446D
6W Q-Band PA	37.5-42.5	38	12	20	24	Die	QPA4346D
10W Q-Band PA	37.5-42.5	40	11	17	24	Die	QPA4246D

Power Transistors and Pallets

Description	Frequency (GHz)	LS Compression Gain (dB)	PAE (%)	Psat (dBm)	Bias (V)	Package (mm)	Part Number
500W Discrete	DC-1.7	15	67	57.3	50	NI-780	QPD1016L
150W Discrete	DC-2.7	15	65	52.5	65	7.2x6.6 DFN	QPD1013
125W Discrete	DC-3.2	16	73	52.1	50	NI-360	QPD1008/L
200W Discrete	DC-3.4	12	60	51	50	NI-360	TGF2819-FL
55W Discrete	DC-3.5	13	50	47.2	28	NI-360	T2G4005528-FS
100W Discrete	DC-3.5	14	72	50	28	NI-360	TGF2929-FL, QPD2929L
2x200W Discrete	DC-3.5	14	68	54	50	NI-650	T1G4020036-FL/-FS
90W Discrete	DC-3.6	16	73	49.5	48	7.2x6.6 DFN	QPD0060
75W Discrete	DC-3.7	15	80	48.5	48	NI-360	QPD1015/L
10W Discrete	DC-4	17	70	41	50	3x3 QFN	QPD1010
15W Discrete	DC-4	17	72	42	50	3x3 QFN	QPD1009
45W Discrete	DC-4	17	72	46.9	48	4x3 QFN	QPD0030
10W Discrete	DC-6	14	56	40	28	NI-200	T2G6000528-Q3
15W Discrete	DC-6	13	65	42.3	28	NI-200	T2G6001528-Q3
30W Discrete	DC-6	11	54	43.5	28	NI-200	T2G6003028-FL
35W Discrete	DC-6	17	78	45.4	48	4x3 QFN	QPD0020
40W Discrete	DC-6	12	52	47	50	NI-200	QPD1035/L
5W Discrete	DC-12	8	50	37	32	3x3 QFN	TGF2977-SM
10W Discrete	DC-12	14	55	40.4	32	3x3 QFN	QPD1022
20W Discrete	DC-12	15	65	43	32	4x3 QFN	TGF2978-SM
25W Discrete	DC-12	25	45	43.4	32	4x3 QFN	TGF2979-SM
27W Die	DC-12	14	54	44.3	32	Die	TGF2954
6W Die	DC-18	18	72	38	28	Die	TGF2023-2-01
12W Die	DC-18	18	73	40.1	28	Die	TGF2023-2-02
25W Die	DC-18	15	78	43	28	Die	TGF2023-2-05
50W Die	DC-18	17	70	47.3	28	Die	TGF2023-2-10
90W Die	DC-18	16	71	50.5	28	Die	TGF2023-2-20
7W Die	DC-25	15	57	38.6	28	Die	TGF2933
10W Die	DC-25	16	58	40	28	Die	TGF2936
7W Discrete	0.03-1.2	16	60	39.4	50	6x5 DFN	QPD1011A
15W Discrete	0.03-1.2	18	70	41	50	6x5 DFN	QPD1014A
25W Discrete	0.03-1.2	18	73	46	50	6x5 DFN	QPD1004A
15W Discrete	0.03-1.215	17	78	42	28	6x5 DFN	QPD1000A
5W Discrete	0.03-3	14	63	37	32	3x3 QFN	TGF2965-SM
10W Discrete	0.03-3	14	63	39.7	32	3x3 QFN	TGF3015-SM
30W Discrete	0.03-4	17	73	44	32	4x3 QFN	TGF3021-SM
1300W Discrete	0.42-0.45	21	81	61.2	65	NI-1230	QPD1026L
1800W Discrete	0.96-1.215	18	77	62.7	65	NI-1230	QPD1025/L
1700W Pallet	0.96-1.215	17	65	62.3	65	108x57 Pallet	QPD1034
300W Discrete	1.0-1.5	15	65	55.4	50	NI-650	QPD2560L
450W IMFET	1.2-1.4	15	62	54.9	45	NI50-CW	QPD1006
500W IMFET	1.2-1.4	17	67	57.3	50	17x24	QPD1003
750W Discrete	1.2-1.4	17	65	58.8	65	NI-780	QPD1028/L
1500W Discrete	1.2-1.4	17	70	61.8	65	NI-1230	QPD1029L
5W Discrete	4-6	9	50	37	32	3x3 QFN	TGF3020-SM

Driver Amplifiers

Frequency (GHz)	Gain (dB)	OP1dB (Psat)	OIP3 (dBm)	NF (dB)	Voltage (V)	Current (mA)	Package (mm)	Part Number
2-9	15	17	23	4.5	5-6	90	Die	CMD232
2-20	27	16	29	3	2-4	145	4x4	CMD295C4/CMD295
2.7-3.8	28	31	30	-	6	400	5x5	QPA1008
4-10	19.5	21	33	5.5	5	143	4x4	CMD315C4
6-14	19	-	20	4	5	74	3x3	QPL3050
8.5-10.5	34	30.8	-	-	6	156	4x3	QPA0812
6-18	24	25	-	6	5	175	4.4x1.2/Die	QPA0022/QPA0022D
6-18	14	30	29	5	5	400	4.5x4.5/Die	QPA0023/QPA0023D
20-45	20	26	31.5	6	5	480	Die	CMD293
26-35	15.5	21	24	4.4	5	90	Die	CMD243

Distributed Amplifiers

Frequency (GHz)	Gain (dB)	OP1dB/Psat (dBm)	OP1dB (dBm)	NF (dB)	Voltage (V)	Current (mA)	Package (mm)	Part Number
DC-20	12	11/13.5	22	2.5	3-8/3-8	40	3x4	CMD311P34
DC-20	13	31/30	38	3.4	10/-0.95	400	5x5/Die	CMD249P5/CMD249
DC-20	19.5	26/25	31	1.9	5-8/-1	200	5x5/Die	CMD192C5/CMD192
DC-20/24	17.5/18	25	31/32	2.5	5-8/-0.65	185	5x5/Die	CMD244K5/CMD244
DC-22	15	22/19	28	2.2	5-8/-0.65	80	4x4/Die	CMD240P4(C4)/CMD240
DC-22	17	20.5/19.5	28	2.5	5-8	108	4x4/Die	CMD284P4/CMD284
DC-30	13	27/28.5	33	3	10/3.5/-0.6	250	Die	CMD292
DC-40	11	21/18	27	4.4	5-8/-0/32	100	4x4/Die	CMD242K4/CMD242
DC-55	12.5	17.5	15	3	5/-0.5	110	Die	QPA0009D
DC-67	10	11/14	11	3.5	3/-0.4	40	Die	CMD304
1-24	16	24.5/24	33	3	5-8	225	4x4/Die	CMD317C4/CMD317
2-20	26.5	17/16	24	3	2-4/2	145	4x4/Die	CMD295C4/CMD295
2-20	9	22/20.5	24	4.5	3-6	120	4x4/Die	CMD233C4/CMD233
2-22	13.5	23/21	28	2.3	5-8/-0.65	74	4x4/Die	CMD241P4/CMD241
2-22	11	18	26	3	6	60	Die	QPA0012D

pHEMT Transistors

Description	Frequency (GHz)	Gain (dB)	Psat (dBm)	NF (dB)	Bias (V)	Current (mA)	Dimensions (mm)	Part Number
0.16W Die	DC-20 (data at 12 GHz)	14	22	1	8	29	0.41x0.34x0.10	QPD2018D
0.25W Die	DC-20 (data at 12 GHz)	14	24	0.9	8	65	0.41x0.34x0.10	QPD2025D
0.40W Die	DC-20 (data at 12 GHz)	13	26	1.1	8	65	0.41x0.34x0.10	QPD2040D
0.63W Die	DC-20 (data at 12 GHz)	12	28	1.4	8	97	0.41x0.34x0.10	QPD2060D
0.89W Die	DC-20 (data at 12 GHz)	11.5	29.5	1	8	130	0.41x0.54x0.10	QPD2080D
1.26W Die	DC-20 (data at 12 GHz)	11	31	1	8	194	0.41x0.54x0.10	QPD2120D
1.78W Die	DC-20 (data at 12 GHz)	10.4	32.5	1	8	258	0.41x0.54x0.10	QPD2160D

Switches

Freq. Min (MHz)	Freq. Max (GHz)	Switch Type	Abs/ Refl	IL (dB)	ISO (dB)	Speed (ns)	P1dB/P0.1dB (dBm)	Voltage (V)	Package (mm)	Part Number
DC	20	SPST	Non-R	1.3/1	48/50	1.8	25	0/-5	3x3/Die	CMD204C3/CMD204
DC	18	SPDT	Non-R	1.75/1.5	46	1.8	23	0/-5	3x3/Die	CMD196C3/CMD196
DC	20	SP4T	Non-R	2.4	39	66	21	0/-5	4x4/Die	CMD203C4/CMD203
DC	26	SPDT	R	1.4	40	3.4	21	0/-5	Die	CMD230
0.100	6	SP3T	R	0.6	34	110	34	3.3	3x3	TQP4M0011
0.2	50	SPDT	R	<2	40	<50	32	0/+3	2.25x2.25	QPC0542
0.15	2.8	SPDT	-	<0.7	>30	30	47	0/-40	4x4	QPC1005
0.15	2.8	SPDT	-	<1	>30	30	47	0/-40	4x4	QPC1006
0.5	6	SPDT	R	<1.1	>40	<50	47	0/-40	5x5	TGS2355-SM
0.5	12	SPDT	-	<1	>30	<35	43	0/-40	4x4	TGS2352-2-SM
0.5	18	SPDT	-	<1.5	>25	<35	40	0/-40	4x4	TGS2353-2-SM
2	11	SP3T	-	1.5	20	50	-	0/-30	4x4	QPC2511
2	18	SPST	R	0.5	25	<170	-	-	Die	QPC1030D/QPC1031D
8	12	SPDT	-	1.2	30	35	41	0/-28	4x4	QPC2040

RF Filters, Diplexers and Switched Filter Banks

Description	Frequency (MHz)	Bands	Technology	IL (dB)	Package (mm)	Part Number
978 MHz Bandpass Filter	977.2-978.8	ADS-B	BAW	3.5	6.43x4.64	QPQ0978
1030 MHz Bandpass Filter	1023-1037	SSR/IFF	BAW	3	3.71x2.57	880367
1090 MHz Bandpass Filter	1082-1098	SSR/IFF	BAW	3	3.71x2.57	880374
L5 GPS Bandpass Filter	1,160.95-1,191.95	L5	TC-SAW	1.2	1.4x1.2	QPQ1062
L2 GPS Bandpass Filter	1,212.1-1,243.1	L2	TC-SAW	1.2	1.4x1.2	QPQ1061
L1 GPS Bandpass Filter	1,559.92-1,590.92	L1	TC-SAW	1.3	1.4x1.2	QPQ1060
L1/L2 GPS Diplexer	1,559.92-1,590.92, 1,212.1-1,243.1	L1, L2	TC-SAW	1.6, 1.3	5x5	QPQ1063
L-Band Switched Filter Bank	1200-1250, 1250-1300, 1300-1350, 1350-1400, 1300-1325, 1325-1350, 1350-1375, 1375-1400, Bypass	L	TC-SAW	3	10x10	QPB1029
Iridium Bandpass Filter	1,616.0-1,626.5	Iridium	TC-SAW	1.7	1.4x1.2	QPQ1065
S-Band Switched Filter Bank	2700-2800, 2800-2900, 2900-3000, 3000-3100, Bypass	S	BAW	3	6x6	QPB1034
S-Band Switched Filter Bank	2900-3000, 3000-3100, 3100-3200, 3200-3300, 3300-3400, 3400-3500, Bypass	S	BAW	3.5	6x6	QPB1036
S-Band Switched Filter Bank	2700-2800, 2800-2900, 2900-3000, 3000-3100, 3100-3200, 3200-3300 Bypass	S	BAW	3.5	6x6	QPB1033

Limiters

Description	Frequency (GHz)	Insertion Loss (dB)	Flat Leakage (dBm)	Package (mm)	Part Number
0.05-6 GHz, 100W VPIN Limiter	0.05-6	<0.7	<17	4x4	TGL2210-SM
0.1-20 GHz, 10W VPIN Limiter	0.1-20	<0.7	<18.5	1.5x1 Die	TGL2217
0.1-20 GHz, 10W VPIN Limiter	0.1-20	<0.9	<18.5	3.5x3.5	TGL2217-SM
1-6 GHz, 100W S-Band & C-Band VPIN Limiter	1-6	<0.5	<16	2x2 Die	TGL2205
2-4 GHz, 200W VPIN Limiter	2-4	<0.6	<18	4x4	TGL2927-SM
2-4.5 GHz, 100W S-Band VPIN Limiter	2-4.5	<0.5	15	2.5x2.5 Die	TGL2206
2-5.5 GHz, 100W VPIN Limiter	2-5.5	<1.0	<15.5	5x5	TGL2206-SM
2-6 GHz, 100W VPIN Limiter	2-6	<0.6	<16.5	4x4	TGL2205-SM
2-12 GHz Wideband Dual Stage	2-12	<0.5	<18	3x3 Die	TGL2201-SM
2-20 GHz, 5W VPIN Limiter	2-20	<1.0	<18	3x3	TGL2208-SM
2-25 GHz Wideband Dual Stage VPIN Limiter	2-25	<1	<18	1.1x1.1 Die	TGL2201
8-12 GHz, 50W VPIN Limiter	8-12	<0.5	<18	2x2 Die	TGL2209
8-12 GHz, 50W VPIN Limiter	8-12	<0.5	<18.5	4x4	TGL2209-SM
X-Band 40W Limiter in Plastic OVM QFN	8-12	<0.5	<19	4x4	QPP2209

Mixers

Description	Frequency RF (GHz)	Frequency IF (GHz)	LO Drive (dBm)	Conver. Loss (dB)	LO-RF Isolation (dB)	LO-IF Isolation (dB)	IIP3 (dBm)	Package (mm)	Part Number
Fundamental Mixer	4-8.5	DC-2.2	+17	7	45	36	21	3x3	CMD251C3
Fundamental Mixer	4-28	DC-3	+17	8	43	50	20	Die	CMD312
Double Balanced	6-14	DC-5	+19	6	43	39	23	3x3	CMD253C3
Fundamental Mixer	6-45	DC-3	+17	9	41	42	20	Die	CMD313
Double Balanced	11-21	DC-6	+19	6	48	44	22	3x3	CMD254C3
Sub-harmonic x2	13-21	DC-4/3	+2	-10/-8.5	22/28	34/48	13/12	3x3/Die	CMD303C3/CMD303
Double Balanced	16-26	DC-9	+19	6.5	40	33	24	3x3	CMD255C3
Fundamental Mixer	20-32	DC-10	+13	7	36	36	18	3x3/Die	CMD180C3/CMD180
Sub-harmonic x2	20-32	DC-7	-2/-4	-8.5/-9.5	36	53	11/10	3x3/Die	CMD310C3/CMD310
Fund./Double Bal.	26-45	DC-12	+17	6.5	37	29	22	Die	CMD181/CMD181K3
Hi IF Mixer	30-46	5-20	+19	8	30	20	21	Die	CMD261

I/Q Mixers

Frequency RF (GHz)	Frequency IF (GHz)	LO Drive (dBm)	Conver. Loss (dB)	LO-RF Isolation (dB)	LO-IF Isolation (dB)	IMR (dB)	IIP3 (dBm)	Package (mm)	Part Number
2.5-15	DC-1	17	-8	45	25	23	22	4x4	QPX0002
4-8	DC-2.4	+20	-6.5	52	27	30	25	4x4	CMD252C4
6-10	DC-3.5	+15	-6	46	20	30	18	4x4	CMD182C4
6-10	DC-3.5	+21	-5.5	40	18	31	25	4x4	CMD257C4
6-26	DC-3	17	-8	40	27	25	21	3.9x3.9	QPX0001
7.5-13	DC-4.5	+15	-5.5	43	23	26	18	4x4	CMD183C4
7.5-13	DC-3.5	+21	-5.5	38	20	29	25	4x4/Die	CMD258C4/CMD258
16-26	DC-9	+19	6.5	40	33	-	24	3x3	CMD255C3
20-32	DC-10	+13	-7	36	36	-	18	3x3	CMD180C3/CMD180
24-34	DC-7	15	-9	30	24	15	19	Die	QPX0004D
30-40	DC-5	15	-7	35	25	25	18	Die	QPX0003D

Multipliers

Description	Frequency	LO Drive (dBm)	Conver. Loss (dB)	LO-RF Isolation (dB)	LO-IF Isolation (dB)	IMR (dB)	IIP3 (dBm)	Package (mm)	Part Number
Passive Multiplier	4-8	8-16	-12	15	48	-	-	3x3/Die	CMD225C3/CMD225
Passive Multiplier	7-11	14-22	-10.5	15	44	-	-	3x3/Die	CMD226C3/CMD226
Passive Multiplier	8-15	16-30	-11	15	32/40	-	-	3x3/Die	CMD227C3/CMD227

Digital Step Attenuators

Frequency (GHz)	Insertion Loss (dB)	Attenuator Range (dB)	Bits	RMS Step Err. (dB)	Switching Speed	Voltage (V)	Package (mm)	Part Number
DC-20	5	32	5	1	–	-2.5/-5.5	3.9x3.9	QPC1008
DC-22/40	1.5/1.2	6	2	0.1	25	0/-5	3x3/Die	CMD281C3/CMD281
DC-22/40	1.9/1.5	12	2	0.2/0.1	25	0/-5	3x3/Die	CMD282C3/CMD282
DC-30	2.9	30	2	+/-2	28	0/-5	Die	CMD324
DC-30	4	31.5	6	+/-0.2	25	0/-5	Die	CMD325
0.1-15	<4.0	31.5	6	–	<30	-3.0 to -5.0	3x3	TGL2226-SM
0.1-48	4.8	31.5	6	–	–	3.3	3.5x3.5	QPC0045
1-31	<4.2	15.5	5	<0.5	<30	-3.3 to -5.0	3x3	TGL2223-SM

Variable Attenuators

Frequency (GHz)	Insertion Loss (dB)	Attenuator Range (dB)	Voltage (V)	Package (mm)	Part Number
DC-20	3.2	33	+0.3 to -8	3x3	CMD285C3

Analog Attenuators

Frequency (GHz)	Insertion Loss (dB)	Attenuator Range (dB)	Voltage (V)	Package (mm)	Part Number
DC-30	1.5	16	-1 to 0	3x3	TGL4203-SM
DC-50	2	17	-1 to 0	Die	TGL4203
2-31	<2	20	0 to 1.5	3x3/Die	TGL2767-SM/TGL2767

Fixed Attenuators

Frequency (MHz)	Attenuation (dB)	Package (mm)	Part Number
DC->40,000	0	0.5x0.5/Die	TGL4201-00
DC->40,000	2	0.5x0.5/Die	TGL4201-02
DC->40,000	3	0.5x0.5/Die	TGL4201-03
DC->40,000	6	0.5x0.5/Die	TGL4201-06
DC->40,000	10	0.5x0.5/Die	TGL4201-10

Digital Phase Shifters

Frequency (MHz)	Number Bits (dB)	Insertion Loss (dB)	Amp. Err. (dB)	Phase Err. (deg)	Package (mm)	Part Number
2.5-4	6	5	<0.4	<5	5x5	TGP2108-SM
5-18	Analog	3.2/3	–	200/400	4x4	CMD297P34/CMD297
6-18	6	<10	0.45	4	5x5/3.15x3.15 Die	TGP2105-SM/TGP2105
8-12	6	6	0.5	4	4x4/2.2x2.2 Die	TGP2109-SM/TGP2109
15-19	6	7	0.85	4	4x4/2.11x1.41 Die	TGP2615-SM/TGP2615
28-32	5	6	0.5	5	1.88x0.75 Die	TGP2100
32-37	5	7	0.4	3.5	1.88x0.75 Die	TGP2102

Upconverters/Downconverters

Description	RF Min (GHz)	RF Max (GHz)	IF Min (GHz)	IF Max (GHz)	LO Min (GHz)	LO Max (GHz)	Conversion Gain (dB)	Package (mm)	Part Number
17.7-26.5 GHz K-Band Upconverter	17.7	26.5	DC	4	6.85	15.25	13	5x5	QPC4510
17-27 GHz K-Band Image Reject Downconverter	17	27	DC	4	6.5	15.5	15	5x5	QPC4610
24-30 GHz IF Up/Downconverter ¹	24	30	2.6	5.8	4.725/6.75	6.75/8.775	12.5	5.7x4.5	AWMF-0210
37-43.5 GHz IF Up/Downconverter	37	43.5	4	7	7.6	10	11	5.7x4.5	AWMF-0218

¹LO min/max depends on low side or high side injection

High-Power, Ultra-Broadband Performance & Solid State Reliability Using Spatium® Technology

Patented Spatium RF power combining technology from Qorvo provides a low loss, broadband, highly reliable, efficient alternative to traveling wave tube amplifiers (TWTAs) for commercial and defense communications, radar, EW and many other RF applications. The Spatium SSPAs dramatically improve broadband RF power and efficiency through patented coaxial spatial combining techniques. These SSPA solutions are offered as standard products with several platforms available across the 2 to 40 GHz spectrum. For those applications that require customer specific SSPAs, Spatium solutions are readily customizable. Qorvo uses its world class GaN MMIC amplifiers to deliver longer service lifetimes than comparable TWTAs. Spatium SSPAs provide clear advantages in size, weight, power, and cost (SWaP-C) at the total solution level. Spatium technology allows unprecedented combining efficiency, specifically over wide bandwidths, with output power up to 750W CW.

Over wide (up to a decade bandwidth) frequency bands and over temperature at CW conditions, Spatium SSPAs provide higher output power and efficiency than conventionally-combined solid-state products.

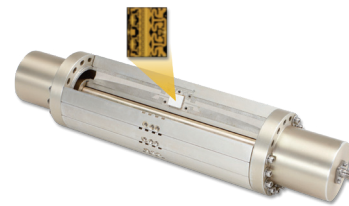
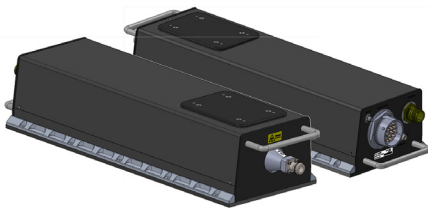

Benefits of Spatium Technology

- Ultra-broadband instantaneous operation: up to decade bandwidth
- Efficiently combines 16 GaN MMIC HPAs
- Provides graceful degradation vs TWTAs single point of failure
- Highly reliable solid-state technology
- Technology readiness level (TRL 9)
- Lower supply voltage compared to TWTAs: 18-28V
- No system warm-up time needed

Applications

- EW/jammers
- Radar/SAR systems
- Satellite communications
- Airborne, shipborne and terrestrial systems
- Test instrumentation

Qorvo introduces Spatium SSPA Modules QPR0220 and QPR3238

Optimized for Seamless Integration and Performance

- Simplifies integration – Compact unit with minimal loss between driver and Spatium
- Boosts yield – Tested and guaranteed as a single unit
- Reduces wiring – Unified power conditioning eliminates extra harnesses
- Enhances reliability – Advanced fault monitoring and notifications

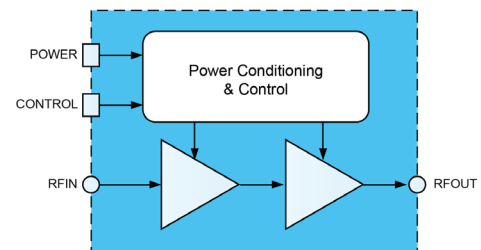

SSPA Amplifiers

Frequency (GHz)	Psat (W)	Small Signal Gain (dB)	Power Gain (dB)	PAE (%)	Voltage (V)	Part Number
2-6	250-320	30-33	18-19	30-37	24	QPB0206N
2-18	8-16	34-38	25.1-28	12-21	18	QPB0220J
2-18	17-40	40-52	39.3-43	9-17	18	QPB0618J
2-18	100-200	17-20	11-14	15-35	20	QPB0218N
2-18	120-263	14-18	8-11	10-25	18	QPB0220N
2-18	120-263	53-60	36-39	13-24	18	QPR0220
6-18	162-288	15-19	9.1-11.6	15-24	18	QPB0618N
8-11	590-740	27-30	19.7-20.7	31-39	28	QPB1024
13.4-15.5	590-645	33-37	23.7-24.1	25-28	28	QPB1316
18-40	16-32	18-25	10-13	6-14	18	QPB1840N
18-40	80-126	13-17	10-12	8-14	18	QPB2040N
27.5-31	150-200	21-24	13-14	22-26	22	QPB2731N
32-38	14-20	50-65	36.5-38	12-15	24	QPB3238J
32-38	126-155	18-25	8-9	13-15	24	QPB3238N
32-38	126-155	55-80	51-52	15-17	24	QPR3238
34-36	316-347	21-25	16-16.4	15-17	28	QPB1111

Space Screening & Qualification

For more than 40 years, Qorvo has been an industry leader and supplier of highly reliable GaN and GaAs technologies for space applications, from low earth orbit (LEO) to deep space. With vertically integrated manufacturing and deep aerospace expertise, Qorvo delivers space screening and qualification aligned to mission requirements, enabling customers to achieve the right balance of performance, reliability and risk.

Qorvo is Your Trusted Space Partner

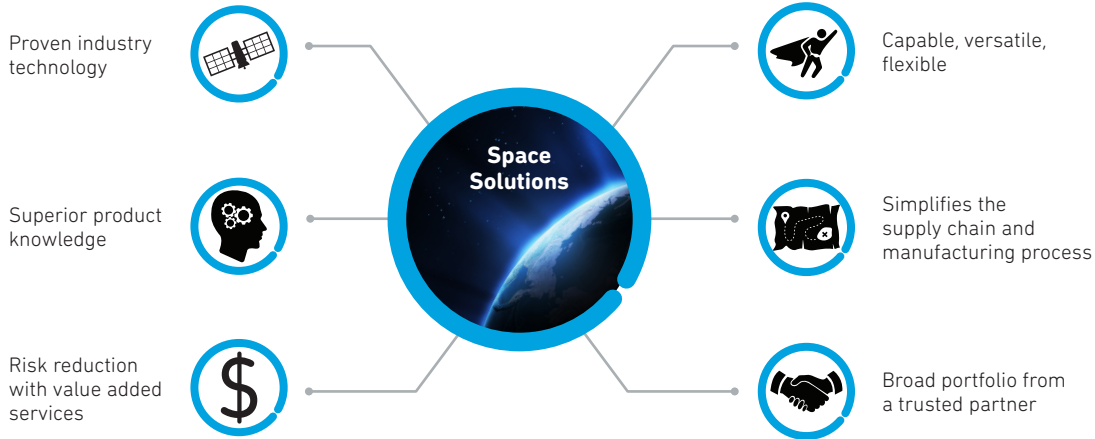

Screening and Qualification Offerings:

Die:

- MIL-PRF-38534 Class K & Individual Services
- Standard Products & Foundry

Non-Hermetic Packages:

- Ceramic Air Cavity
 - Derived from MIL-PRF-38535, NASA EEE-INST-002
- Plastic Over-mold
 - Derived from NASA PEM-INST-001, MIL-PRF-38535

Custom:

- Opportunity Driven
- Customer Specific Requirements
- SCD Controlled

Visit qorvo.com/go/space to find out more.

	LEO 500 – 2,000 km	MEO 2,000 – 20,000 km	GEO 35,786 km	
Space Mission Profile	Class C Mission	Class B/A Mission		Class A Mission
Portfolio / Model	Enhanced Commercial Product (ECP)	Radiation Tolerant Product (RTP)		
Screening Level	Full traceability Wafer Lot Acceptance* limited screening PEM & NHC	MIL-PRF-38534 Class K or H (Die)	EEE-INST002, MIL-PRF-38535 Class P (PEM)	EEE-INST-002 MIL-PRF-38535 Class Y (NHC)

<p>LEO – Class C Mission</p> <ul style="list-style-type: none"> • Lower-risk missions • Cost-effective solutions • PEM or non-hermetic ceramic 	<p>MEO – Class B/A Mission</p> <ul style="list-style-type: none"> • Balanced performance & reliability • Full traceability • Limited screening for PEM and non-hermetic ceramic 	<p>GEO – Class A Mission</p> <ul style="list-style-type: none"> • High reliability for critical missions • Radiation tolerant devices • Supports die, PEM, and non-hermetic ceramic flows
--	---	---

Compact, Powerful, Dependable: Advanced Packaging

Through Elite360SM Foundry & Services, Qorvo delivers advanced packaging solutions built on industry-leading heterogeneous integration technologies that help customers accelerate development, reduce risk and optimize system performance. Combining U.S.-based manufacturing, design support, die-to-package assembly and test capabilities under one roof, Qorvo provides a streamlined path from concept to qualified production, supporting Trusted Model and Microelectronics Quantifiable Assurance (MQA) requirements.

Open Foundry Services for Flip-Chip Packaging

Wafer/Die Prep Services:

- Augments core wafer foundry services
- Wafer fab and packaging under one roof
- Provides proven design environment tools to DIB

Heterogeneous Integration:

- Mature: 2D MCM, QFN
- Emerging Flip-Chip: 2D RF SiP, DSMBGA
- Advanced: 2D/3DR RF SiP, 2.5D Si

Flexible Design Ownership:

- Customer design
- Qorvo design
- Customer/Qorvo co-design

Die Sourcing:

- Industry-leading GaN, GaAs, RFIC, SAW/BAW
- III-V + silicon technologies
- 3rd party die options
- Passives

Visit qorvo.com/go/elite360 to find out more.

Once the initial designs are complete, Qorvo offers an advanced, domestic, secure and cost-effective assembly and test center, co-located with the wafer fab for a complete design to certification on-shore solution.

Design Center Offers Complete Services

Access:

- Design simulation
- Layout and verification PDK/ADK

Collaborate:

- Qorvo design/co-design options

Architect:

- Next-gen SiP platforms
- Packaging IP block libraries

Design and Verify:

- Circuit and layout
- Integrated mixed signal EDA platform

Validate:

- Test SiP prototype test/characterization
- Multichannel and mixed-signal capability

Manage:

- Advanced life cycle management tools

Wafer/Die Preparation Services

Qorvo offers a fully-integrated, domestic DMEA Cat 1A foundry, a trusted RF foundry service.

Features & Benefits



Reduce Cost, Time, Logistics

- Vertically integrated, turnkey operation
- Single supplier, single PO



Trusted Supplier

- 30 years of RF: defense, aerospace, mobile, etc.
- DMEA: category 1A "Trusted Source"
- All on-shore operations



Cutting Edge Technology

- World leader in RFIC/MMIC solutions
- RF-testing capability up to 50 GHz
- Advanced Microwave Module Assembly/SHIP
- Ability to process Pb-bumped wafers

Services for 8" Si Wafers

Phase 1 CY 22/23



Post Processing

- Bump (outsourced)
- Probe
- Grind
- Dice
- Visual Inspect
- Pick & Pack

Phase 2 CY 24



Assembly

- Packaging
- Packaging Test

Phase 3 CY 25

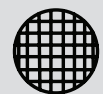

Turn-Key

- External Foundry Management & Interface

Qorvo's goal is to connect, protect and power the planet by boosting mission performance for defense and aerospace applications. Our 30+ years of RF experience gives our customer confidence in their choice of foundry and packaging partners.

Visit qorvo.com/go/elite360 to find out more.

Check Out Our Design Hub

Qorvo connects the world. From the IoT and smartphones to defense and everything in between. Explore our resources to find out how.

Resource Categories:

Downloadable Software



GaN Models



Array Calculators

SATCOM Array Calculator
5G Array Calculator

Design Tools

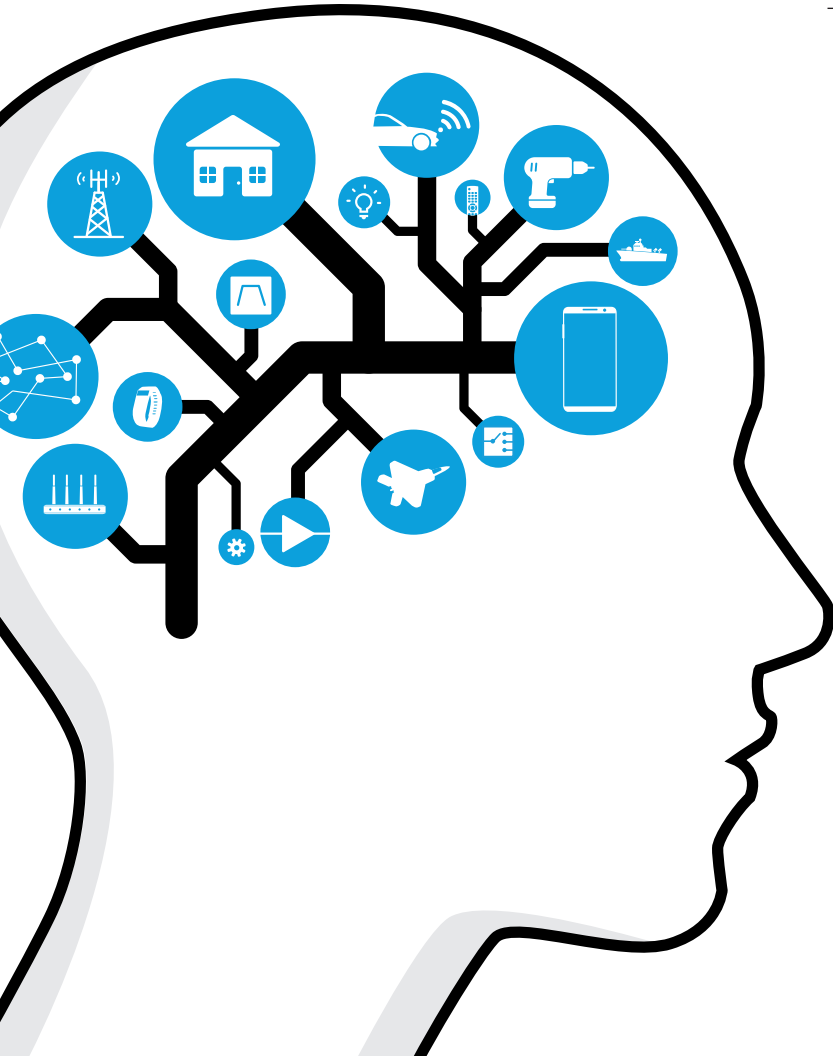
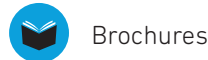
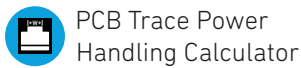

Here to Inspire and Help

Qorvo has a long and proud history of providing RF designers and engineers, from around the world, with the inspiration and technical support they need to make their designs a reality. In addition to designing and manufacturing the industry's best in class RF and mmWave products, Qorvo provides the system level technical know-how that enables true design collaboration. Qorvo stands ready to support our valued customers so they can overcome their toughest design challenges together.

www.qorvo.com/design-hub

Experience the Strength in Numbers

Qorvo Connects, Protects and Powers Near and Far

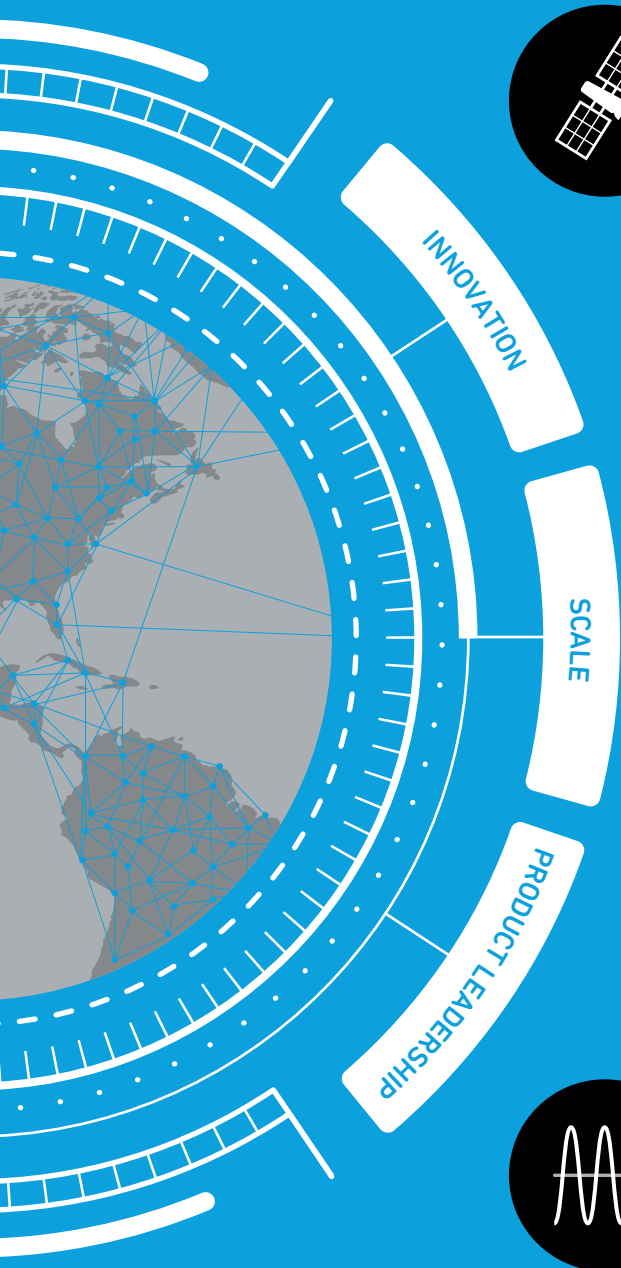

Space qualified,
highest level of reliability



Demonstrated GaN MTTF reliability
with **200°C/10⁷ hrs**



Over 10 million
GaN products shipped to date



#1 GaN-on-SiC supplier
in defense since 1998



4 GaN process nodes at **MRL 10**
using USAF MRA tool

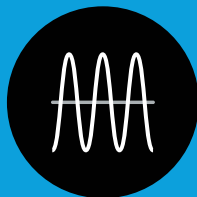

Broadest portfolio range
20 MHz~100 GHz

Join us at [Qorvo.com/design-hub](https://www.qorvo.com/design-hub) to explore:
Blogs | Videos | e-Books | Design tools | Tech docs

© 06-2026 Qorvo US, Inc. | QORVO, ALL AROUND YOU, MATCHCALC, QSPICE,
ZERO-CAL and SPATIUM are trademarks of Qorvo US, Inc.

